



# QUALITY INDUSTRIES INC.

THERE IS NO SUBSTITUTE FOR **QUALITY**

- ▶ SHOP SUPPLIES
- ▶ FLUID FLOW
- ▶ PAINTS & CHEMICALS
- ▶ FASTENERS
- ▶ ELECTRICAL
- ▶ ASSORTMENTS
- ▶ AUTO FLEET
- ▶ BODY SHOP



# QUALITY INDUSTRIES INC.

THERE IS NO SUBSTITUTE FOR **QUALITY**

- *Assortments*
- *Bins & Storage Equipment*
- *Chemicals & Paints*
- *Fasteners*
- *Non-Stock & Special*
- *Auto Fleet*
- *Body Shop*
- *Electrical*
- *Fluid Flow*
- *Shop Supplies*

*Quality Industres, Inc.  
1595 Ocean Ave. Unit B1  
Bohemia, NY 11741*

*Tel: 631-981-3354  
Fax: 631-981-3664  
info@quality-industriesinc.com*

### **Corporate Overview:**

Since 1962 Quality Industries Inc. has been serving our customers with quality products and unmatched services. Our product line includes fasteners, hoses and fittings, drill bits, chemicals, electrical connectors and shop supplies. Today we are a fast growing force in the automotive and industrial maintenance aftermarket. We service our customers from our distribution center located in Holbrook, New York.

### **The primary markets we service include:**

- Agriculture
- Manufacturing
- Construction
- Fleet
- Commercial
- Government
- Automotive
- Institutional

If you can't find what you're looking for in our catalog please call us and let us know what it is. One of our trained technical solutions specialists will provide special ordering options to help you save time and money!

### **Government Sales:**

Quality Industries is a Woman Owned Small Business that welcomes the opportunity to provide procurement solutions to our Federal Government customers. We are proud to offer thousands of high performance American made products designed to save you time and money.

- Quality Industries is a Woman Owned Small Business
- Quality Industries is CCR & ORCA Registered
- Corporate CAGE code: 50ZY7
- DUNS #: 013564257
- NAICS codes: 423710, 444150, 423840, 423120, 424690, 424130
- Quality Industries can participate in Micro Purchases, Simplified Acquisitions, and Full and Open Bidding.

Let us provide you with solutions to your next procurement problem.



Item	Qual#	Page
<b>A</b>		
Abrasive	M-9* M-25 MMM#	105
Abrasive Wheels	20140 * 20147	106,103
Acid Brushes	M-7	100
Adhesive	MMM-08001 *	104
Aerosol Products		
Brake Clean	11811 & MMM#	121, 123
Brake quiet	Per-127MA	Loctite
Bust Rust	1051A, 1051B	121, 125
Carb. Cleaner	11816	121, 125
Cutting Tool Coolant	BK360	125
CRC	CRC-	Mfg
Engine start Fluid	11818	121
degreaser	11844	121
Glass cleaner	11821, 11821-AF, 11805	121, 125, 120
Grez-Off	11899	125
Fast Tack, High-tack	11087, Per98H, 99MA	125
Paint	PLA-208 *, Kry-1601 *	126
	Kry-1613	126
Penetrating oil	1051A	121
Silicone Spray	11810	121
Lock De-Icer	11820	121
Windshield De-Icer	11815	125
Under coat, spray	80018	121
Vandel remover	801	125
White-grease	11814	121
WD-40	WD-10108	125
Afta Products	AF4003,4007	125
Air Brake: Diaphragms	V-031021*V-031035	109
Air Brake: Fittings		
Air Brake: Hose		
Air Dry: Brake	11817, 11819	121
Air Hose & air, fluid couplers	M-123 * M-141 M-151 * M-158 M-164 * M-173	130 * 133
Air Masks, Filters	24344, 24345	Mfg
	MMM-07048,-06985	116
Air Guns, Chucks	M-118-600S, M-114 M-115, M-126	130
Alarms, Back-up	41-706 * 41-761	Pollak
Alligator Clips	20105 * 20110	126
Anchors		86-87

Item	Qual#	Page
Expansion	11672 * 11686	86
Kap-toggle	15050 * 15055	86
Lag, screw shields	11601 * 11608	87
Nylon, plastic	13240 * 13375	86
Toggle	15128 * 15178 15056 * 15063	86
Vinyl	11691 * 11698 11707 * 11721	87
Misc. anchors, tools	23950 * 23982	86
Anti-Freeze	Z11800, Z11800P	-
Anti-Freeze tester	20176	
Auto & strip calk	MMM-08578	82/ 3M cat.
Body	AU-1001	125
<b>B</b>		
Back-up Alarms	41-706 * 41-761	Pollak
Ball joints	36866 * 36873	38
Yolks	37737 * 37742 37788 * 37793	38
Bars Leak	11822	125
Batteries	65081 * 65084 65121, 65151, 65131	25
Battery Accessories	20034 * 20036,	24
Bolts	M-464, 1033	23
Cables	1100 * 1113 15690 * 15731	63 27
Crimper	19995	27
Jumper cable, ends	5107, 5109, 5110	126
Electralink slug & tubing	M-900 * M-912	25
Terminals	1045 * 1051, 1070 * 1085 1060 * 1069 1093 * 1098 20027, M-96* M-97	62 63 23
Terminal protectors	M-98, M-99	24
cleaner	11823, 11824	125
Battery filler	328	108
Belt Dressing	Per-120DA BD-316	Loctite
Bins & Cabinets	9999 *	59-60
Labels	9994 * 9998	60
Bio-Friendly Cleaners & Degreasers - <i>Beyond Clean</i>		138

## TABLE OF CONTENTS

Item	Qual#	Page
Blades		101-103
Bayonet		102
Jab		Lenox
jig		101
Hack	M-594-X * M-596-X	103
Frame	M-593	103
Saws All		102
Blitz can	340 * 342	108
Body shop hardware		C section
Body Clips	20051 * 20053	28
Bolts		
Battery	M-464	23
Body		C11-C14
Bumper		C31
Counter-bor	2180 * 2245	77
Carriage	8110 * 8194	90
Grade #5	6006-USS-6496	88
	6506-SAE-6994	88
Grade #8	7006-USS-7504	89
	7506-SAE-7998	89
Bucket tooth	1395 * 1417	77
Hex flange	2250 * 2266	77
Elevator	1425 * 1438	77
Plow	1300 * 1365	76
Square machine	1850 * 1890	77
Screen	1370 * 1387	76
Spring center	32422 * 32433, 36323 32802 * 32804, 35950	52
Step	1440 * 1453	77
Stove	2620 * 2715	76
Tap	8044,8094-98	90
Toggle	15050 * 15055 15128 * 15178	86
metric		78-80
Stainless	4008-USS-4156 4212-USS-4237 4180-SAE-4208	92
License plate		C9-C10
Booster cable	5107 * 5110	126
Box sealing tape	M-223	119
Brake		
Fluid	11838 * 11841	125

Item	Qual#	Page
Fluid pump	380	-
Hose, vacuum	V-022038 * V-022044	Velvac
Clean, spray	CRC-5089 Per-123DA, Per-82220 11811	- Loctite, 125
Disc quiet	Per-127MA	Loctite
Steel line	24990 * 25057 2155 * 2158	41
<b>Brass Fittings</b>	15808 * 19701	Weatherhead
<b>Brass Nuts</b>	18250 * 18256	Weatherhead
Bronze Stop Leak	11829	121
Bucket & Pails	314 * 320, 330	107-108
Bulbs		
Mini	12200 * 12284	45
Bumper Bolts	32239 * 32247 35554 * 35567	C31
Metric	38380, 39660	C31
Butt Connectors		
Grease filled	M-573 * M-575	19
Bust Rust	1051A	121
Brushes, Brooms	20160 * 20165	100
	60200 * 60238	100
<b>C</b>		
Cable		
Control, choke	5150 * 5156	-
Stripper	1019	61
Ty-Rap ties & access.	1025, 1155, 1156	63
	12077 * 12085-M	64
	13458-J * 13461-J	64
Wire	15452 * 15580	26-27
Battery	15690 * 15731	27
Cap Screws		
Flat-head socket	50390-USS-50481 50618-SAE-50665	75
Button-head socket	50490 * 50505 50506-USS-50518	75
Grade #5	6006-USS-6496 6506-SAE-6994	88
Grade #8	7006-USS-7504 7506-SAE-7998	89
giant	8355-USS-8388 8755-SAE-8788	90





Item	Qual#	Page
Metric		78-80
J.I.S. Metric small head	41777 * 41795	84
Socket-head	50060-USS-50236 50283-SAE-50381	75
Stainless-hex	4008-USS-4156 4212-USS-4238 4180-SAE-4208	92
Carb.Cleaner, spray	11816	125, 121
Carb.Cleaner, soak	Per-46Y,Per-46YB	Loctite
Carb. Clips	30609 * 30614 30784,30785	52
Cable & Chain	60000-Gr.40-60025 60026-Gr70-60029	97
skid	60030	-
Chain hooks	60040 * 60058	98
Thimbles	60105 * 60112	98
Quick-links	60080 * 60085	98
Shackles	60086 * 60094	98
Wire rope clip	60095 * 60102	98
Cold shut	60060 * 60064	98
Chain products	60065 * 60076	99
Tow chain	60151	-
Load binder	See BX & BXR #'s	99
Chassis Clamps	20051 * 20053	28
Cheese Graters	80606, 80619, 80677	103
Choke Cables	5150 * 5156	-
Kits	5551,5552	-
Locking controls	5180 * 5186	-
Power take-off control	25190 *25196	-
Vernier	5215 * 5220	-
Cotter Pins	2740 * 2826	71
Metric	49356 * 49361	82
Stainless	4654 * 4684	93
Center Bolts	32422 * 32433	52
	32802 * 32804	52
Circuit Breakers	54-115 * 54-730	Pollak
Auto ATC	20300 * 20304	43
Circuit Testers	20121	126
Clevis Pin	2130 * 2137 36433 * 36447	36
Clamps		
Jiffy	20042 * 20047	28

Item	Qual#	Page
Cable, tube	20060 * 20066 20260 * 20268 20270 * 20276	28
Booster cable	5109 * 5110	126
Hose	24930 * 24958	34
Stainless	24959 * 24975	34
Muffler	25070 * 25099	42
Cobalt Drill	22712 * 22743	67
<b>Coll-O-Crimp</b>		
Commutator & Emery Paper	M-9 * M-10C	105
Contact Cleaner	Per-123DA	Loctite
Connectors		
Grease filled butt	M-573 * M-575	19
T-tap	M-567-X	20
Self-strip	M-800	22
Scotch blue, yellow, brown	M-567-A, -C, -D	21
Bullet receptacle	M-567-B	21
	M-629, M-628	19
Copper Tubing	2140 * 2153	41
Cutter	20124	41
Flare tool	20123, 20128	41
Cord, extension	15585 * 15593	118
Couplers, Air	M-133 * M-141 M-151 * M-167	131 * 132
Creepers & Parts	5238 * 5240	106 / ETW
Crimping Tools	1023	61
	20134	19
Cable	19995	27
Crushproof Exhaust Hose	2035 * 2062	-
CRC Products	CRC #s	CRC
Cutting Fluid, spray	BK-360	125
<b>D</b>		
DL Hand soap	DL-25-218	120
Discs	M-13-25 * M-28	105
Adaptor	M-17, M-18	105
Dies & Taps		
Hex die	22664 * 22705	68
Diesel Fuel Conditioner	See FP- #s	122 * 124
<b>Drain Cocks</b>	16941, 19183	
Drain Pans, Buckets	310, 314 * 320	107
Drain Plugs & Gaskets	19924 * 19938, 20117-18	30

## TABLE OF CONTENTS

Item	Qual#	Page
Drain Plug, Quick	M-500*	135-137
Drawers	10000 *	59-60
Drills		
Assortments, sets	20574 * 20578	65
Carbide	22800 * 22816	66
Cobalt	22712 * 22743	67
Double end	22615, 22620	67
Extractor, screw	24800 * 24812	69
Fractional, split point	22455 * 22483	65
Index, stands	20563, 20874 * 20887	65
Left hand	20524 * 20531	67
Letter	23119 * 23144	65
Longboy	22600 * 22606	67
1/4" shank	22484 * 22491	66
1/2" shank	22492 * 22522	65
3/4" shank	22530 * 22540	New PG
Masonry	22800 * 22816	66
Metric	23146 * 23164	66
Stubby	22610 * 22620	67
Wire gauge #	23059 * 23118	67
Reamers	24782 * 24790	66
Unibit	24815, 24816	69
Drill Bits	2920 * 2925	72
Drop Light	15600 * 15607	118
Dry gas	11836	125
Duct Tape	M-227 * M-230	119
<b>E</b>		
"E" Ring Retainers	M-651 * M-659-C M-707 * M-713	56
Electrical Tape	M-215-J	119
ElektraLink Terminals	M-640 * M-642	20
Emergency Triangles	130	116
Emery Paper	M-9, M-10, M-10-C	105
Engine Starting Fluid	11818	121
Degreaser	11844	121
Exhaust Tubing	2035 * 2062	-
Extension Cords	15585 * 15593	118
Extractor	24800 * 24812	69
Expansion Plug		
Flex	31393 * 31405	29
Steel	30937 * 30973	30

Item	Qual#	Page
<b>F</b>		
FPPF Products		122-124
Face Shields		-
Eye	24341 * 24343, 24351	116
Eye wash	50001	MFG
Breathing	24344	-
Fast Tack	11087	125
Filament Tape	M-223	119
Filters- Baldwin	B- #s	Baldwin
Filter Masks	MMM-07048/06985	116
Filter Wrench	362 * 367	-
Finishing Washers	43165 * 43179	71
Fire Extinguisher	756	116
<b>Fittings, Brass</b>		
Flare Tools	20123, 20128	41
Flashers	12390 * 12404	47
Flashlights & Batteries	65080 * 65150	25
Flexible Exhaust Hose	2165 * 2178	MFG
Clamps	17054 * 17062	42
Foul Weather Gear	85 * 92	116
Floorboard Screws	3031 * 3046	74
Freon-R134	Z11900	125
Front End Shims	297452, 29453 30155 * 30158	36
	32074 * 32099 37705, 37706	36
Fuel Fill Hose	817003 * 818003	
Fuel Line, Hose Plug	2080 * 2084	40
Fuel Injection Hose	2090 * 2092	40
Fuel Injection Cleaner	11846	121
Fuses & Holders	M-3240 * M-3245	43
ATC	20888 * 21462, 20254	43
(MINI) ATM, ATLM	20346 * 20363	43
MAXI	20519 * 20523	43
Holder	20006 * 20009	43-44
AGA	22889 * 22898	44
AGC	22924 * 22937	44
AGS	22920 * 22923	44
AGX	22910 * 22912	44
AGW	22899 * 22905	44
FMX	20511 * 20517	44



Item	Qual#	Page
GBC	22906 * 22909	44
SFE	22938 * 22944	44
Pal Link	22960 * 22969	43
Puller	22915	44
Tap	M-611 / -611-M	43
Fuse Extension/plug	M-609-FA & M-611-MF	44
Fuse Block Clips	19800	19
Funnels	347 * 355	108

**G**

Garbage Liners	75194 * 75196	117
Gas Cans	340	108
Gas Line Hose & Ends	2080 * 2084	40,W/H
Glad Hand Seals & Couplers	V-035038/ 42/ 45	109,Velvac
Glass Cleaner	11805,11821,11821-AF	120, 121, 125
Gloves,Work	01-1000 * 01-1011	117
Goggles, safety	24341 * 24343	116
Glasses	24351	116
Grease, Misc Chemicals	306	107, 125
Grease Fitting	56387 * 56412	54
Grease Gun & accessories	300 * 305	106-107
Mini portable Lube	290	-
Grinding Wheels	20140 * 20147	106
Grommets	20070 * 20075	29
Nylon	M-32 * M-38	29
Gunk Products	11810 *, 5903, 1051A	121

**H**

Hacksaw		
Frame	M-593	103
Blades	M-594-X*M-596-X	103
Hairpin Retainers	30168 * 30177 36110 * 36114 368 * 36894	51
	37393 * 37398 38872 * 38874	51
Hand Soap & Cleaners	DL-21-218 DL-40-406	120
Hard Hat	24362, 24363	116
Heat Gun	1175, 1176	62
Heater Hose,	2070 * 2076	40
Sureflex	56280 * 56306	40
Silicone	2077 * 2089	40
Hearing Protectors	24364	-

Item	Qual#	Page
Head Lamp Retaining Parts		C39 *
Hex Keys	32414 * 32419	54
High Tack	Per-98H / -99MA	Loctite
Hole Saw	AM-30009 * 30096	101
Arbor	AM-30001 * 30006	101
	AM-1200 L Kit	101

Hooks	60040 * 60058	98
Hose Asst. with Rack	3549	-
Rack	3548	-
Hose Clamps	24940 * 24958	34
Truck Exhaust clamp	17054 * 17063	42

**Hydraulic Hose & Ends**

HydraLink Terminals	M-830 * M-835	20
Hydraulic Oil	11834, 11835	125
Hydrometers, battery	20175	24

**I**

Ice Melt	11826 50lb. (KCL)	125
	11876 45lb. (KCL)	125
	11880 50lb. (NACL)	125

**J**

Jack Oil	11834	125
----------	-------	-----

**K**

Key Stock	36794 * 36802, 45530	52
Rack	10038	52, 60
Kopr-Shield	1030 * 1031	63
Krimpa-Seal	M-769 * M-829	20

**L**

Labels	9994 * 9998	60
Lag Screws	15179 * 15215	87
Shields	11601 * 11608	87
License Plate		
Bolts		C9-C10
Retainer		C9-C10
Screws		C9-C10
Holder		Sig. Stat
Light Bulb	12200-mini-12284	45
Lamps		
Seal beam	12300 * 12323	46
Halogen	12339 * 12348	46
Florescent	12365, 12366	47
Rough service	12350 * 12357	47



## TABLE OF CONTENTS

Item	Qual#	Page
Flood	12358 * 12361	47
12 V	12362, 12363 / 69 / 70	47
Lens & Lamps	Sig- #s	Sig. Stat
Links	60060 * 60102	99
Load Binder	BX- & BXR-	99
Locknut, chemical	Per-24200 * Per-29040	Loctite
Loctite Products	Per- #s	Loctite
Lock washers		
American	43000 * 43029 43045 * 43047 43140 * 43152	70
Loom		
Plastic	15630 * 15643	-
Flex-gard	15644 * 15656	28
Lubricants		
Cool-Tool	BK-360	125
White lube spray	11814	125, 102
Red Grease	306-R	107
Graphite Drylub	858	-
GE silicone White	1130, 11130	-
Black	1131, 11131	-
Clear	11132	-
White Lithium Grease	5903, 11814	125
Lubri Plate Cartridge	5906, 11800, 11812	125
Lug Wrench	343 * 346	-
Lynch Pins	38732 * 38736	52
<b>M</b>		
3M Products		104-105
Manifold Caps	31439, 31440 39209, 39210 39907, 39908	52
Masking Tape	3M	119
Mechanics Wire	M-678 *	-
Magnetic Hex Drive	2915 * 2917	72
Metric Hardware		78-85
Mirror Adhesive	Per-11067	Loctite
Mirror, Truck	Sig-	Sig. Stat
Moulding Clips		"C" sec.
Muffler Clamps, Hangers	25070 * 25095	42
<b>N</b>		
Nuts		
Acorn cap	4366 * 4375	93
Brass		

Item	Qual#	Page
Castellated	1650-USS-1659 1750-SAE-1761	91
Finished	1500-USS-1512 1600-SAE-1612	90
Grade 8 alloy	2500-USS-2513 2600-SAE-2613	90
Stover gr. "C" lock	8310-USS-8319 8320-SAE-8329	91
Stover L-9	8330-USS-8339 8475-USS-8477	91
	8340-SAE-8349 8480-SAE-8482	91
Heavy hex	1675-USS-1685	91
Hex flange	2270, 2271	77
Hex stainless	4400-USS-4403 4394, 4412, 4413 4395-SAE-4399	93
machine	4549 * 4553	96
High	1665-SAE-1672	91
Jam	8230-USS-8239 8240-SAE-8249	91
Keps	1540 * 1549	91
Lock, stainless	4330 * 4365	93
Machine	1532 * 1538	91
Metric	49219 * 49243 49300 * 49315	81
Nylocks	1516-USS-1530 1618-SAE-1630	91
Nylon stop, thin	1634-USS-1643 1734-SAE-1745	91
Nylon stop, high	1490-SAE-1499	91
Reversible lock nuts	38740 * 38745	90
Spinlock	32167, 36857, 37669 29769 * 29770	C7
	29895 * 29897 32596 * 32598	C7
Nuts		
Wing	1552 * 1561	91
Wing, stainless	4377 * 4385	92
Pal	1564 * 1570	91
	29557 * 29562	-
Nut setters	2915 * 2917	72
Wheel nuts	11790 * 11791	



Item	Qual#	Page
Nutserts	37264 * 38314	53
Tool & Kit	38805, 38806	53
<b>O</b>		
"O" Ring	31305 * 31356	39
"O" Ring, Metric	31304M * 31356M	39
"O" Ring Make a Kit	Per-0157	Loctite
Oil Fill Bottles	1290	106
Oil Measures	322 * 327, 375 * 377	108
Oil Drain	310, 311, 314 * 316	107
Spout	308, 309	107
Pistol	335 * 339	108
Oil Quick Changer	M-500 * M-531	135-137
<b>P</b>		
Paint Brushes	60235 * 60238	100
Paint, Spray	Pla-, Kry-, TA4, TA5	126
Paper Goods	75190 * 75192	117
Parts Cleaning	Per-46Y, Per-46YB	Loctite
Brushes	20130, 20133	100
Machines		Kleer Flo
PCV Hose	2101, 2102	40
Permatex Items	Per-	Loctite
Penetrating Oil		
Bust Rust	1051A	121
WD40	WD-10108	125
CRC	CRC-	CRC
Pipe Sealant	Per-59214 Per-59231	Loctite
Pigtail & Sockets	19945 * 19990	31-33
Pigtail-self stripping	M-800	22
Plastic Rivets, retainers	40645, 40999, 41045 41004 * 41016 41023 * 41038	C-0.2 & 0.3
Plastic "T"	37101 * 37110 37368, 38321, 38419 37697, 39928	53
Plow Bolts	1300 * 1365	76
Plow Light Kit	72-5531	Pollak
Plug Buttons		
Chrome	30750 * 30756, 1800	29
Plastic	36288 * 36293, 1801	29
Pollak connectors	11-402 * 54-730	Pollak
switches		Pollak

Item	Qual#	Page
alarms		Pollak
solenoid		Pollak
breakers		Pollak
Powersorb. Maint sorbent	MMM-07164 * MMM-07167 SPC-100	104, 116
<b>Q</b>		
<b>R</b>		
Radiator Anti-Rust	11832	-
Radiator Flush	11830	-
Radiator Hose	56280 * 56306	40
Adaptors	56310 * 56317	-
Radiator Sealer	11829	121
Rain Gear	85 * 92	116
Razor Blades	20453, 41575	103
Reflectors & Flares	Sig-	Sig.Stat
Reamers	24782 * 24790	66
Retaining Rings		
"E"	M-651 * M-659-C M-707 * M-713	56 - 58
External	M-991 * M-1003 M-1040 * M-1056	56 - 58
Internal	M-1011 * M-1030	58
Rivet & Rivet Guns		
Drive	8580 * 8600	-
Solid	8620 * 8631-M	-
Aluminum pull	10140 * 10181	48
Steel pull	10184 * 10205	48
Stainless pull	10206 * 10212	48
Special	37348 * 37359 10240 * 10279	49, 50
Guns & access.	10220 * 10223	50
Roll Pins	35981 * 36055	35
Rubber Products		
Grommets	20070 * 20075	29
Tips	31439, 31440, 39209 39210, 39907, 39908	52
Rubber Hold Downs	2120 * 2125 3556, 3559	42
Rubber Lube	11833	-

## TABLE OF CONTENTS

Item	Qual#	Page
<b>S</b>		
Safety Equipment	24341 * 24351	116
	24364	-
Sandpaper (3M)	M-9 * M-11	105
Saws		
Bayonet	AM-20716 * AM-20730	102
Hacksaw	M-593 * M-596-X	103
Hole	AM-1200L kit AM-30009 * AM-30096	101
Sorbent Pads	SPC-100	116
Saws		
Saws all	AM-20502 * AM-20585	102
Jig	AM-20602 * AM-20690	101
Scotchlok Connectors	M-567-A * M-567-D	21
Scrapers	20120, 20126	126
Scratch Brushes, steel	20131, 20132, 60213	100
Screws		
Floor board	3031 * 3046	74
Lag	15179 * 15215	87
Machine	45295 * 45894	72
Self threading	45200 * 45263	72
Metric	49000 * 49052	84
Sheet metal	46061 * 46725 2961 * 3024	73-74
Bit	2920, 2922, 2925	72
Drywall	2905 * 2912	74
Tek	46740 * 46882	73
Socket set screw	32365 * 32413	54
Socket wench	32414 * 32419	54
Torx	38937 * 38946 41046 * 41053	74
Wood	See SS 4900 * 4930	95
Black	37162 * 37183	C27
	37652 * 37654, 39957	C26
	38084 * 38093	C27
	38453 * 38457	C28
	38784 * 38792	C26
	39213 * 39218	C28
	39950 * 39955	C28
Stainless steel	3965 * 3990	96
	4418 * 4447	95
	4448 * 4498B	96

Item	Qual#	Page
Stainless steel (cont.)	4499 * 4548B	96
	4555 * 4573	94
	4692 * 4707	94
	4708 * 4725	96
	4726 * 4739	94
	4772 * 4788	95
	4792 * 4841	95
	4845 * 4895	95
	4900 * 4930	95
	4935 * 4996	96
Screen	1370 * 1387	76
Screw Extractor	24800 * 24811	69
Screw Driver	21025	126
Socket Head Cap Screws	50060-USS-50236 50283-SAE-50381	75
Screw Anchors		
Expansion	11672 * 11686	86
Kap toggle	15050 * 15055	86
Lag screw shield	11601 * 11608	87
Nylon, plastic	13240 * 13375	86
Toggle	15056 * 15063 15128 * 15178	86
Vinyl	11691 * 11698 11707 * 11721	87
Misc anchors	23950 * 23982	86
Seal Clamps	17054 * 17063	42
Sealed Beams	12300 * 12323	46
Halogen	12339 * 12348	46
Seat Tape	M-227 * M-230-2	119
Shims	29452, 29453 30155 * 30158	36
	32074 * 32099 37705, 37706	36
Shrink Tubing	1054 * 1059 1180 * 1184	62
Signal Hose	2098, 2099	-
Signal Stat	Sig-	Sig. Stat
Silicone Spray	11810	121
	Per-116DA	Loctite
Sockets, Bulbs	See	31-33
Solder	M-1093 * M-1097	130
Spray De-icer	11815, 11820	125, 121



Item	Qual#	Page
Spray Paint	Pla-	126 Plasti-kote
	Kry-	126 Krylon
Speed Nuts	TSN-	C17-C25
Metric fold over nuts	38624 * 38631 38864, 69575	C24
Springs, Universal	20090 * 20097	38
Stainless Steel		92-96
Bolts	4008-USS-4156 4212-USS-4328 4180-SAE-4208	92 92 92
Cotters	4654 * 4684	93
Screws	3965 * 3990 4418 * 4447 4448 * 4498B 4499 * 4548b 4555 * 4573 4692 * 4707 4708 * 4725 4726 * 4739 4772 * 4788 4792 * 4841 4845 * 4895 4900 * 4930	96 95 96 96 94 94 96 94 95 95 95 95
Washers	4393, 4685, 4686 4404 * 4407 4414 * 4415	93
Lock	4389, 4416, 4417 4408 * 441 4687 * 4690	92
Starting Fluid	11818	121
Strike Force Cleaner	11900, 11900-5	120
Sponge Rubber Weather strip	31850 * 31861	106
Squeegees	60223	100
Steel Brake Line	24990 * 25057 2155 * 2158	41
Stop Leak	11829	121
Stick-on Reflectors	Sig-	Sig Stat
Studs	36667 * 36748	55
Metric	49411 * 49434	83
Wheel	11792 * 11793	37
Suction Pump	307	107

Item	Qual#	Page
Super Glue	Per-49411, Per-49450	Loctite
Super Lube	Sup-31041	125
	Sup-51011-1	
	Sup-11016	
	Sup-12004	
Switches	15-400 *	Pollak
<b>T</b>		
Tap & Die	24596 * 24661	69
Pipe	22651 * 22656	68
Taper	22622 * 22648 24670 * 24674 22821 * 22823A	68
Plug	24542 * 24548 24556 * 24575	68
	22824 * 22826A 24675 * 24679	68
Bottom	24549 * 24555 24576 * 24595	68
	22827 * 22829A 24680 * 24684	68
Brute	22830 * 22846	68
Metric	22850 * 22860	69
Hex die	22664 * 22705	68
Tapes		
Cloth	M-227 * M-230	119
Electrical	M-215-J	119
Teflon	M-214	119
Filament	M-223	119
Masking	MMM-6334-1	119
Wrap 'n seal	M-213	-
Tail Pipe Hangers	25099	42
Teflon Sealant Tape	M-214	119
Tek Screws	46740 * 46882	73
Terminals, Electrical	M-260 *	16-22
Terminal Protectors, Battery	M-98, M-99	24
	11823	125
Cleaner	11824	125
Test Lights	20121	126
Thermostats	14180, 14195	-
Threaded Rod	13166-USS-13175 15007-USS Gr 8-15011	87
	15013-SAE Gr8-15022 13196-USS Gr8-13200	87

## TABLE OF CONTENTS

Item	Qual#	Page
Metric	48720*48737 49687 * 49689	83
	49692	83
	49696 * 49704	-
Stainless	13210 * 13217	87
Threaded Inserts	300039 * 300108	-
	37264 * 37290	53
	38310 * 38319	53
Thread Repair	Perma Coil	129
Tie Down Straps	2120 * 2125, 3556	42
Tire Supply		
Cement	M-144-8, M-145	127
Gauge	M-147 * M-153	127
Patches & repair	M-146-	127
Valves	14001 * 14007	127
Extensions	M-113	127
Caps	14010 * 14013	127
Repair kit	M-162	128
Toggles	15050 * 15055	86
	15056 * 15063	86
	15128 * 15178	86
Torch	1175	62
Torx Bit	3055 * 3059	74
Trailer Connectors	11-720 * 11-723	Pollak
	38434 * 38435	32
Trailer Cable	15575 * 15580	26
Trays, Bins	9999 * 10050	59-60
Transmission Cooler	11875	-
Transmission Hose	2094, 2095	-
Transmission Fluid	11847	125
Truck Flaps	11850 * 11856	113
Truck Equipment	K-430001	Mfg
	Velvac	110-113
	57000 * 57052	114-115
Truck Lights, Lens	Sig-	Sig.Stat
Truck Mirrors	Sig-7002 *	Sig.Stat
	V-700024 *	Velvac 111-113
Tube Benders	20127	41
Tubing Clamps	20060 * 20067 20260 * 20288	28
	20124	41

Item	Qual#	Page
Tubing		
Copper	2140 * 2153	41
Nylon		
Polyethylene		
Shrink	M-637 * M-639	20
	1054 * 1059	62
Signal	2098, 2099	-
Steel, Brake line	2155 * 2158 24991 * 24997 25032 * 25037	41
Tuff-skin Drop Light Bulbs	12356, 12357	47
Thomas & Betts		61-64
Cable strip tool	1019	61
Crimping tool	1020	61
Cable slicers	1021	61
Box-organizer	1174	61
Installing tool	1023	61
Heat gun	1176	62
Threaded stud	1060 * 1066	63
"Y" splices	1067 * 1068	63
Clamp	1154	63
Shrink tubing	1054 * 1059 1180 * 1184	62
Starter cable splices	1086 * 1092	63
Conductive, anti-seize comp	1030, 1031	63
Cable-battery, starter	1100 * 1113	63
Cable-ties, tools	1025, 1155, 1156	63
	12077 * 12085-M 13458-J * 13461-J	64
Torch	1175, 1177A	62
Battery Cable Connector	1035 * 1051	62
Starter Lug	1070 * 1085	62
Tomco Ftg		131-134

### U

Undercoat, Spray	80017 * 80018	121, 125
Unibit Drill	24815 * 24816	69
Utility Knife/ Blades	M-599 * M-600	103

### V

Vacuum Hose	2085 * 2088	40
Vacuum Tee's	37108 * 37110, 37368	53
Vandal Remover	801	125



Item	Qual#	Page
Valve		
Caps	14010 * 14013	127
Cores	14001 * 14005	127
Extensions	M-113	127
Heater	C880 Series *	134
Tire	14006, 14007	127
Velcro Hook & Loop	M-90 * M-91	42, 106
Velvac Products	V-	Velvac
Vernier Control Cables	5215 * 5220	-
<b>W</b>		
Waste Can, oil	356	108
Washers		
Countersunk star	43091 * 43097	71
Fender	43157 * 43159	71
External star	43030 * 43041	71
Flat	43200-USS-43210	70
	43226-USS-43239	70
	43250-SAE-43262	70
	43278-SAE-43291	70
	8561-USS Gr8-8573	70
	8548-SAE Gr8-8557	70
Flat copper	42913 * 42919	71
Flush finishing	43165 * 43179	71
Internal star	43060 * 43073	71
Lock Gr 8	43000 * 43018 43020 * 43029 43045 * 43047	70
Metric, lock	49258 * 49281	82
Flat	49192 * 49202 49288 * 49290	82
Spring	49082 * 49291	82
Star assort.	43099	71
Spring	43111 * 43116	70
Steel split	43140 * 43152	70
Stainless, flat	4404 * 4407 4393, 4414, 4415 4685 * 4686	93
Lock	4408 * 4417 4687 * 4689	92
Countersunk finish	4640, 4755 * 4758	
Tension control L9	8460 * 8472	70
Rhinalloy Flat - Extra Thick	8640 * 8649	71

Item	Qual#	Page
Washer Solvent & Anti-freeze	11837	121
	Z11800	-
Water Pails	320, 322 * 327 329, 330	107-108
Well Nuts	M-684	C-1.0
Weather strip	31850 * 31861	106
Wheel Weights, Stud, Nut	24840 * 24929	37
White Grease	11814	121, 125
Windshield		
De-icer	11820	121
Repair kit	Per-16067	Loctite
Spray cleaner	11821	121
	11805	120
Wiper blades	RR-,RAN-,RSB-,RWB-	-
Wiper hose	2086 * 2088	40
Wing Nuts		
Stainless	4377 * 4385	92
Steel	1552 * 1561	91
Metric	49450 * 49457	82
Wire		
Flat molded	15567 * 15570	26
Mechanics	M-678	-
Primary	15452 * 15498	27
	15500 * 15551 15559 * 15570	26
Speaker	15571 * 15572	-
Trailer cable	15575 * 15580	26
Wire Brushes	20131, 20132, 60213	100
Wire wheels	20180 * 20189	84
	20160 * 20165	100
Wire Cable	15452 * 15498	27
	15500 * 15551 15559 * 15570	26
Wire Loom	15644 * 15655	28
Wire Nuts	19796 * 19798	19
Wire Rope Clips	60095 * 60102	98
Wire Rope Thimbles	60105 * 60112	
Wire Ties	1025, 1155, 1156	63
	12077 * 12085-M	64
	13458-J * 13461-J	64
Wiring Clamps	20060 * 2006, 20260	28







## Vinyl & Nylon Insulated Solderless Terminals

"Funnel Barrel" - Electrolytic Tin-plated Copper - Color Code Identification

Vinyl #	Wire Size	Screw Size	Nylon #	RING TONGUE
M-551	22-18	5-6	M-551-N	
M-556	22-18	8-10	M-556-N / NI	
M-552	22-18	3/8	M-552-N / NI	
	22-18	1/4	M-546-N / NI	
	22-18	5/16	M-547-N / NI	
M-550	16-14	5-6	M-550-N	
M-553	16-14	8		
M-557 / -I	16-14	10	M-557-N / NI	
M-559 / -I	16-14	1/4	M-559-N	
M-558	16-14	5/16	M-558-N / NI	
M-577	16-14	3/8	M-577-N / NI	
M-549	12-10	8-10	M-549-N / NI	
M-560	12-10	1/4	M-560-N / NI	
M-548	12-10	5/16		
M-561 / -I	12-10	3/8	M-561-N	
M-791 / -I	12-10	1/2		

Vinyl #	Wire Size	Screw Size	Nylon #	HOOK TONGUE
M-569	22-18	4-6		
M-570	16-14	8-10	M-570-N	
M-571	12-10	8-10		

Vinyl #	Wire Size	Screw Size	Nylon #	SPADE TONGUE
M-618 / -I	22-18	8-10		
M-563	16-14	4-6		
M-564 / -I	16-14	8-10		
M-565 / -I	12-10	8-10		
M-648	16-14	1/4		

Vinyl #	Wire Size	Screw Size	Nylon #	BLOCKED FLANGED SPADE
M-781	22-18	4-6		
M-619	22-18	8-10		
M-620	16-14	4-6		
M-621	16-14	8-10		
M-622	12-10	6		

Vinyl #	Wire Size	Screw Size	Nylon #	BLOCKED SPADE TONGUE
M-562	22-18	4-6		

Qual #	Wire Size	Blade Width	Nylon #	FEMALE QUICK DISCONNECTS
M-582	16-14	3/16		
M-427-C / CI	16-14	1/4		
M-428-C	12-10	1/4	M-428-CN	
M-429-C	22-18	1/4		

Vinyl#	Wire Size	Nylon#	SNAP PLUG
M-292-C	16-14		
M-293-C	16-14		

Vinyl#	Wire Size	Nylon#	3 WAY "Y"
M-432-3	16-14		
M-433-3	12-10		

Vinyl#	Wire Size	Nylon#	4 WAY "X"
M-432-4	16-14		
M-433-4	12-10		

Vinyl#	Wire Size	Nylon#	BUTT TYPE
M-566 / -I	22-18	M-566-N / NI	
M-567 / -I	16-14	M-567-N / NI	
M-568 / -I	12-10	M-568-N / NI	
M-580	16-14		
M-581	12-10		

### MALE-FEMALE SELF MATING QUICK DISCONNECT



Qual #	Wire Size	Blade Width
M-612-C	16-14	3/16
M-613-C	16-14	1/4
M-614-C	12-10	1/4
M-794	12-10	3/8

### MALE QUICK DISCONNECT



Qual #	Wire Size	Blade Width
M-583	16-14	3/16
M-430-C / CI	16-14	1/4
M-431-C	12-10	1/4
M-429-CF	22-18	1/4

**Vinyl Insulated Specialty Terminal**  
c/ 1/4" Tab 16-14 Ga Bx /25  
M-576



**SNAP PLUG RECEPTACLE**  
M-265-X





# Non-Insulated Solderless Terminals

## Non-insulated Electrolytic Tin-plated Copper



Qual#	Wire Size	Screw Size	RING TONGUE
M-270	22-18	5-6	
M-271	22-18	5-6	
M-272	22-18	8-10	
M-289	22-18	3/8	
M-768	16-14	4-6	
M-262	16-14	4-6	
M-273	16-14	10	
M-275	16-14	1/4	
M-584	16-14	3/8	
M-585	12-10	5-6	
M-274	12-10	8-10	
M-276	12-10	1/4	
M-263	12-10	5/16	
M-277	12-10	3/8	
M-588	12-10	1/2	

Qual#	Wire Size	Screw Size	SPADE TONGUE
M-283	16-14	8-10	
M-284	12-10	8-10	

Qual#	Wire Size	Screw Size	BLOCKED SPADE
M-287	22-18	4-6	
M-264	16-14	4-6	

Qual#	Wire Size	Screw Size	BLOCKED FLANGED SPADE TONGUE
M-286	16-14	4-6	
M-589	16-14	8-10	

Qual#	Wire Size	Screw Size	HOOK TONGUE
M-261	22-18	4-6	
M-288	16-14	8-10	
M-260	12-10	8-10	

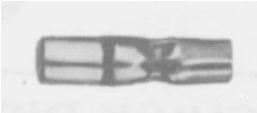
Qual #	Blade Width	SNAP PLUG
M-292	16-14	
M-293	16-14	
M-616	16-14	
M-617	12-10	

Qual #	Wire Width	PLUG RECEPTACLE
M-268	18-14	

Qual#	Wire Size	Screw Size	RING TONGUE FLAG TYPE
M-285	22-18	10	
M-278	16-14	10	
M-279	14-12	8-10	

Qual#	Wire Size	Blade Width	MALE QUICK DISCONNECT
M-601	18-14	3/16	
<i>Use with M-605</i>			
M-602	12-18	1/4	
<i>Use with M-607</i>			
M-603	20-14	1/4	
<i>Use with M-608</i>			

Qual#	Wire Size	Blade Width	FEMALE QUICK DISCONNECT
M-604	28-24	1/8	
M-605	18-14	3/16	
<i>Use with M-601</i>			
M-427-W & WC	12-10	WIDE	
M-606	18-14	1/4	
<i>Use M-427-C</i>			
M-607	12-8	1/4	
<i>Use with M-602</i>			
M-608	20-14	1/4	
<i>Use with M-603</i>			

Qual#	Wire Size	Blade Width	FEMALE QUICK DISCONNECT - FLAG TYPE
M-609	22-18	3/16	
M-610	18-14	3/16	
M-787	18-14	1/4	

### SELF MATING MALE-FEMALE QUICK DISCONNECT

ONE PART TAKES THE PLACE OF TWO

Qual#	Wire Size	Blade Width	
M-612	18-14	3/16	
M-613	18-14	1/4	
M-614	12-8	1/4	
M-615	12-8	3/8	

Qual #	Blade Width	BUTT TYPE
M-280	22-18	
M-281	16-14	
M-282	12-10	

## Terminals

### Heavy-Duty Insulated

#### #8 WIRE INSULATED TERMINAL PKG 10

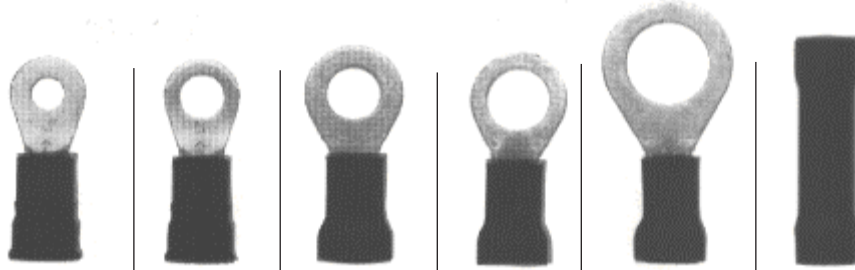

Stud Size	#10	1/4	5/16	3/8	1/2	<b>BUTT CONNECTOR</b>
Desc	Ring	Ring	Ring	Ring	Ring	
Qual #	19795-10	19795-14	19795-56	19795-38	19795-50	19795

#### #6 WIRE INSULATED TERMINAL PKG 10

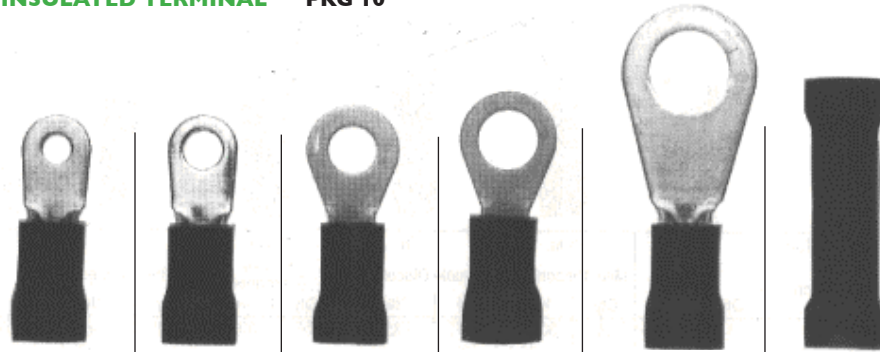

Stud Size	#10	1/4	5/16	3/8	1/2	<b>BUTT CONNECTOR</b>
Desc	Ring	Ring	Ring	Ring	Ring	
Qual #	19794-10	19794-14	19794-56	19794-38	19794-50	19794

#### #4 WIRE INSULATED TERMINAL PKG 10

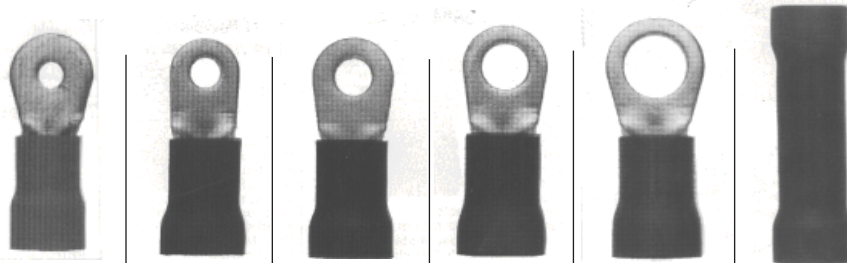

Stud Size	#10	1/4	5/16	3/8	1/2	<b>BUTT CONNECTOR</b>
Desc	Ring	Ring	Ring	Ring	Ring	
Qual #	19793-10	19793-14	19793-56	19793-38	19793-50	19793

### Heavy-Duty Non-Insulated

Solderless Terminals  
Electrolytic Tin-plated Copper

#### RING TONGUE TERMINAL

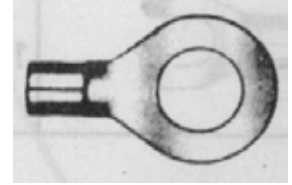

Qual #	Wire Size	Screw Size
19760	8	1/4
19762	8	5/16
19764	8	3/8
19766	8	1/2
19768	6	1/4
19770	6	5/16
19772	6	3/8
19774	6	1/2
19776	4	1/4
19778	4	5/16
19780	4	3/8
19782	4	1/2

#### BUTT CONNECTOR Non-insulated Tin-Plated Copper

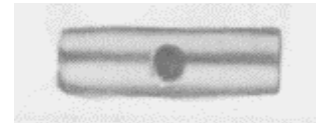

Qual #	Wire Size
19790	8
19791	6
19792	4
M-579-U	8

Qual #	GA	Size
19783-56	8	5/16
19783-38	8	3/8
19784-56	6	5/16
19784-38	6	3/8
19785-56	4	5/16
19785-38	4	3/8
19785-50	4	1/2
19786-56	2	5/16
19786-38	2	3/8
19786-50	2	1/2
19787-38	1	3/8
19787-50	1	1/2
19788-38	1/0	3/8
19788-50	1/0	1/2
19789-38	2/0	3/8
19789-50	2/0	1/2

**COPPER RING TERMINALS - BOX 25**



Qual #	WireGa	Style	Blade Size
M-631	22-18	M	.250
M-632	22-18	F	.250
M-625	16-14	M	.250
M-626	16-14	F	.250
M-633	12-10	M	.250
M-634	12-10	F	.250
M-649	16-14	M	.187
M-650	16-14	F	.187

**FULLY INSULATED QUICK DISCONNECT**



Qual #	WireGa	Style	Blade Size
M-797	22-18	M	.110 x .020
M-799	16-14	M	.110 x .020

**QUICK DISCONNECTS**



**EASY STRIPPER** Qual # 20134

Wire stripper with built-in cutter/crimper. Automatically self-adjusts from 12 to 26 gauge wire (solid or stranded) This heavy-duty Wire Stripper is quick and easy to handle.

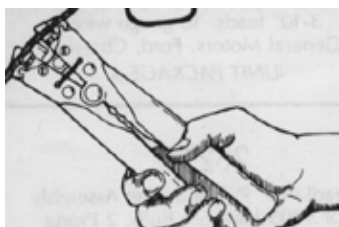

**EASY STRIPPINGS** - It strips the first time, every time without damaging the conductor. Wire is placed in the Stripper as shown above. As force is applied, the left jaw closes, grips and measures the wire. Additional pressure opens the main center jaw and strips the wire clean!



**EASY CRIMPING**- Cliphlight's "Easy Stripper" also crimps insulated solderless terminals. Alloy steel jaws and an insulated plastic handle make this amazing WIRE STRIPPER an extremely durable tool that you can count on time after time

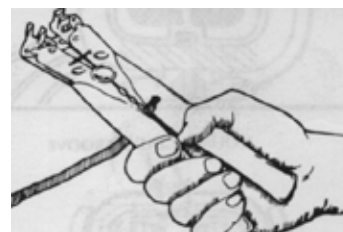

**EASY CUTTING**- "Easy Stripper" also cuts wire! Ruggedly constructed from SAE 1045 material that meets or exceeds all professional requirements this Stripper will provide you with a fast, clean, smooth, operation. Wire repairs and assemblies are made much easier.

**Electrical Terminals and Accessories**

**BULLET RECEPTACLES**

Converts wire to snap plug receptacle for Quick connection/disconnection. Mates with M-292-C snap plug and other .156 Dia. Bullet plugs. Color coded plastic insulation.

Qual #	M-629	M-628
Wire	22-18	16-14



**GREASE FILLED BUTT CONNECTORS - NYLON INSULATED**

Comes Factory Packed with Special Grease

Qual #	WireGA	Color
M-573	22-18	Red
M-574	16-14	Blue
M-575	12-10	Yellow



All boxed 25 & (-C) / 100

**INSULATED FEMALE FLAG**

Qual #	WireGA	Tab
M-627	16-14	1/4
M-627A	22-18	



Box / 50

**FUSE BLOCK ACC CLIP** Qual # 19800

Snaps into fuse box to add accessories, radios, CB's, lights, ETC

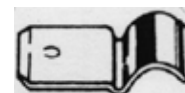

**NYLON PIGTAIL**

One piece, copper connector, non-insulated or with nylon insert. Used for copper to copper connections.

Qual #	Cu Cond. Range	A	Length
5072-A	22-14	.69	.313
5072	22-10	.73	.281

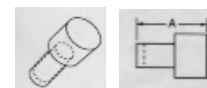

**WIRE NUTS**

Qual #	Wire Combo Range	Color
19796	Min 2 #18 GA Max 2# 14GA	Orange
19797	Min 2# 14 GA Max 3# 12 GA	Yellow
19798	Min 2# 14 GA Max 3# 10 GA & 1# 12 GA	Red



**KRIMP A-SEAL**

Krimpa-Seal, the all-weather, heat sealable sleeve terminal, is available in a variety of designs. This product incorporates an adhesive-lined, heat-shrinkable tubing plus the finest metal connectors available.

**Instructions:**

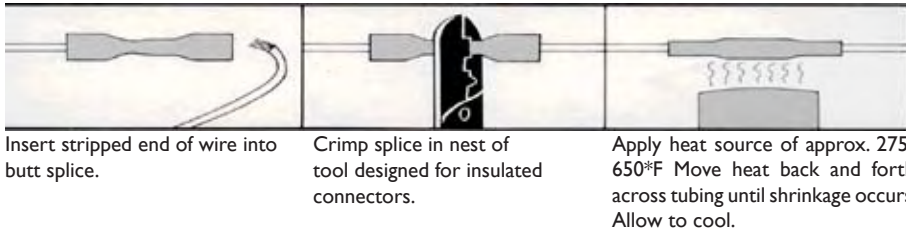

Insert stripped end of wire into butt splice.

Crimp splice in nest of tool designed for insulated connectors.

Apply heat source of approx. 275-650°F Move heat back and forth across tubing until shrinkage occurs. Allow to cool.

**BUTT CONNECTORS**



Qual #	Wire GA
M-637	22-18
M-638	16-14
M-639	12-10

Qual #	Wire GA	Stud	Thickness	<b>RING TERMINALS</b>
M-769	20-18	#6		
M-770	20-18	#8		
M-771	20-18	#10		
M-772	20-18	1/4		
M-773	20-18	5/16		
M-774	20-18	3/8		
M-801	16-14	#4-6	.032"	
M-802	16-14	#8	.032"	
M-803	16-14	#10	.032"	
M-804	16-14	#12-14	.032"	
M-805	16-14	5/16	.032"	
M-806	16-14	3/8	.032"	
M-807	12-10	#6-8	.040"	
M-808	12-10	#10	.040"	
M-809	12-10	#12-1/4	.040"	
M-810	12-10	5/16	.040"	
M-811	12-10	3/8	.040"	
M-812	12-10	1/2	.040"	

Qual #	Wire GA	Style	Tab Size	<b>COUPLERS</b>
M-780	20-18	F	.250"	
M-788	20-18	M	.250"	
M-819	16-14	F	.250"	
M-820	16-14	M	.250"	
M-821	12-10	F	.250"	
M-822	12-10	M	.250"	

Terminals come box /10 or (-C) box/100

**DISCONNECTING T-TAP**

Qual #: M-567-X

For tapping current from 18-14 gauge wire. Automotive, fleet, and accessory shop applications. No stripping is required. Place wire to be tapped in location notch and close with common pliers. Tap in FULLY INSULATED and ready to accept M-625 and M-631. (See pg. 19 on Electrical Terminals.) Bx /25

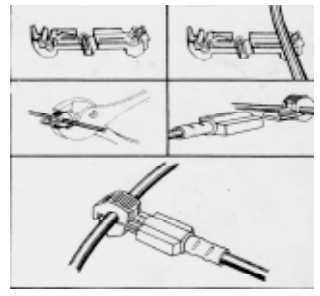

Qual #	Wire GA	Stud	Thickness	<b>SPADE TERMINALS</b>
M-775	20-18	#6	.032"	
M-776	20-18	#8	.032"	
M-777	20-18	10	.032"	
M-813	16-14	#4-6	.032"	
M-814	16-14	#8	.032"	
M-815	16-14	#10	.032"	
M-816	12-10	#4-6	.040"	
M-817	12-10	#8	.040"	
M-818	12	#10	.040"	

Qual #	Wire GA	Plug Size	<b>BULLET PLUGS</b>
M-829	20-18	0.157"	
M-827	16-14	0.157"	

Qual #	Wire GA	Style	Tab Size	<b>SLIP-ONS</b>
M-778	20-18	F	.250"	
M-779	20-18	M	.250"	
M-823	16-14	F	.250"	
M-824	16-14	M	.250"	
M-825	12-10	F	.250"	
M-826	12-10	M	.250"	

**ELEKTRALINK CONNECTOR SERIES**

Qual #	Wire GA	<b>BUTT</b>
M-640	20-18	
M-641	16-14	
M-642	12-10	

**HYDRALINK CONNECTOR SERIES**

Qual #	Wire GA	Bx	<b>INLINE</b>
M-830	White 24-22 AWG Red 20-18 AWG	10	
M-831	Red 20-18 AWG Blue 16-14 AWG	10	
M-832	Blue 16-14 AWG Yellow 12-10 AWG	5	
M-833	Yellow 12-10 AWG Red 8 AWG	10	

Qual #	Wire GA	Bx	<b>CLOSED END</b>
M-834	22-14	10	
M-835	18-10	10	



# Connectors

Easy, Instant Connections For Tap, In-line, And Pigtail Splices.

Designed For Modern Transportation Cars, Trucks, Trailers, Boats, & Accessories.

**FLIP-TOP** snap cover gives **RESILIENT** added protection.

**SELF-STRIPPING** "U-Element" eliminates stripping and soldering, saving time and money.

**CHANNEL STOP** contains bare wire end.

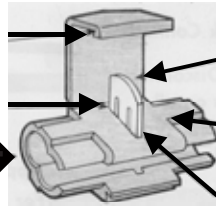

**SPRING ACTION** provides firm, positive grip against vibration.

**PRE-INSULATED** U-Element" and conductors are encased in polypropylene.

**UNIFORM CONDUCTOR** contact area gives dependable service. Won't chip, crack, or dry-out.



**Qual #**      **Color**

M-567-C      Yellow      Designed exclusively for 10 or 12 gauge splicing on heavy-duty vehicle wiring.

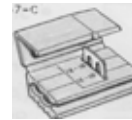

**Qual #**      **Color**

M-567-A      Blue      Designed for use on 14, 16, and 18 gauge automotive wiring.



M-567-AJ      Blue      100

M-567-AL      Blue      500

**Qual #**      **Color**

M-567-D      Brown      Heavy Duty. For connecting 14, 16, and 18 gauge to 10 or 12 gauge automotive wire. Ideal for over-the-road equipment where tap, in line, and pigtail splices are required.



**Qual #**      **Color**

M-567-E      Red      Designed for automotive and truck accessories, radios, tapes, speakers, etc. Tap channel is 14 to 18 gauge .



## THE FASTEST & EASIEST CONNECTOR

- Color-Coded for easy identification
- No wire stripping or special tools needed
- Insulated when top flap is snapped in place.
- Works on 10 thru 18 gauge stranded or solid wire.
- Perfect connection every time. Just insert wires and press U-Element with pliers.
- U.L. listed for tap splices up to 300 volts.
- No slack, or cutting of run wire needed for tap off.
- Installed cost 50% less than any other connector.

All Box of 25

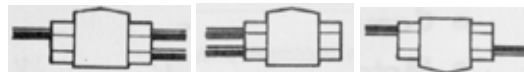

## Special Terminals

### TERMINAL-MALE SLIT TAB-BRASS

Qual #: M-764



### TERMINAL-FEMALE BRASS

Qual #: M-763



### INSULATOR-MALE use with m-764

Qual #: M-764-A



### INSULATOR-FEMALE

use with m-763

Qual #: M-763-A



### CONNECTOR-NYLON INSULATED-CLOSED END-SOLDERLESS

Qual #: 5072-A

Used for splicing any combination of wires totaling from 22-14 Gauge



Qual #: 5072

Used for splicing any combination of wires totaling from 18-10 Gauge



### CONNECTOR-WIRE

Qual #: M-783

3 WAY "Y" Type  
Bakelite Insulation Silver  
Plated Brass Body. ALL  
PASS. & TRUCKS ALL  
YEARS

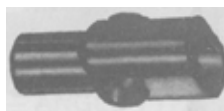

### VINYL FEMALE CONNECTOR

Qual #: M-265-X

2 WAY



### ADAPTOR TERMINAL

Qual #: M-623

Snap type for 2 female and 1 male  
snap terminal. Used for attaching 3  
terminals as a quick connector.

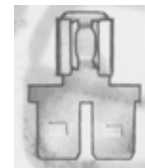

### TERMINAL PIGGY-BACK

Qual #: M-624



20-12 wire size. Incline female quick disconnect over 1/4" male blade. Snaps onto 1/4" male tabs and allows extra tab on each connection for future power outlets.

### TERMINAL-BRASS

Qual #: M-421-G

Distributor and Spark  
Plug Wire

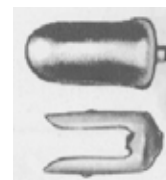

### 3M SELF-STRIPPING ELECTRICAL PIGTAIL CONNECTOR

(Flame Retardant) contains EG-3 Sealant

Qual #	Box
M-800	10
M-800-I	25
M-800-L	50
M-800-J	100

1. Insert 2 or 3 unstripped wires completely into connector and check wire position by looking through the translucent connector body.

2. Hold tool perpendicular to the wires and make the connection by driving the cap down flush with the edge connector body.

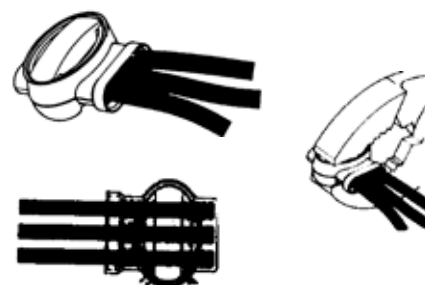

# Battery Terminals & Accessories

## COPPER ALLOY TERMINAL

Qual #: 20027

Copper alloy terminal grips cable firmly and directly to Battery.

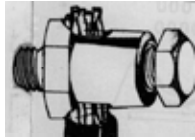

Can be used as a regular tapered battery post for recharging attachment OR to attach a regular terminal.

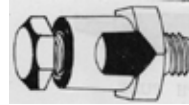

A terminal lug can also be attached directly to post.

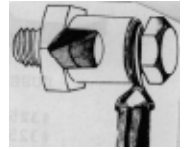

## SIDE TERMINAL BOLTS

Qual #: 20028

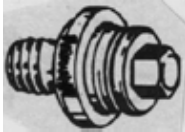

## SIDE TERMINAL

Qual #: M-97

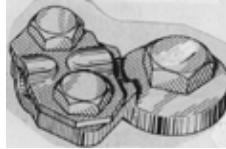

## ALL LEAD UNIVERSAL TERMINAL

Qual # Fit

M-96 Fits 6 GA-OO GA

M-96-9 Fits 0 GA-OOO GA



## BATTERY BOLTS

Qual #: 464-A



Qual #: 464

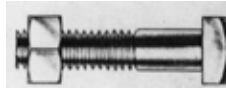

Qual #: 1033

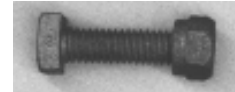

## BATTERY POST EXTENDERS

Qual #: M-105

Qual #: M-105-L (long)



## PLASTIC BATTERY TRAY Qual #: 20033

- One universal size for most batteries.
- Cannot corrode, rust or shock from electrical shorts.
- Extremely durable for long life.
- Costs less than metal types.
- Easy to install. Can be drilled if necessary to match existing hardware.
- Has centering arrangements for battery size 21-27.

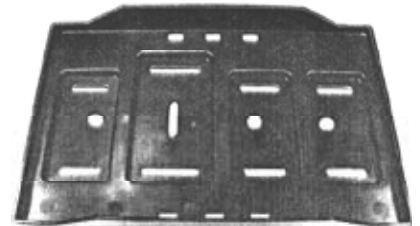

Qual #	Quantity	Size
10-8970	10	1/4-20 x 4-3/4
10-8971	10	1/4-20 x 9
10-8963	10	5/16-18 x 8
10-10644	10	3/8-16 x 10
10-10643	10	5/16-18 x 12
10-8964	10	5/16-18 x 10

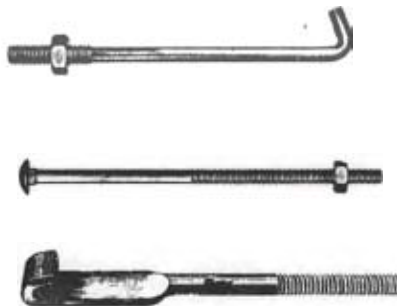

## MARINE BATTERY TERMINAL

Qual #: M-96-M

Universal 5/16 stud Marine Battery Terminal with clamp type wing nut. Card of 10

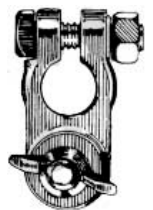

## Battery Accessories

### BATTERY POST & TERMINAL CLEANER

Qual #: 20170



### BATTERY TERMINAL POST & CLAMP CLEANER

Qual #: 20171



### BATTERY TERMINAL CLAMP LIFTER

Qual #: 20174



### TERMINAL CLAMP SPREADER, REAMER, & POST CLEANER

Qual #: 20172



### PROFESSIONAL BATTERY TESTER

Qual #: 20175



### BATTERY CARRIER

Qual #: 368



### TOP POST BATTERY TERMINAL PROTECTOR

Qual #: M-98



### SIDE BATTERY TERMINAL PROTECTOR

Qual #: M-99



### REPLACEMENT BATTERY NUT

Qual #: V-058068



### UNIVERSAL CROSS BAR BATTERY HOLDDOWN

Qual #: 20034

Replaces five OEM designs and fits three top selling battery groups (24, 22F, 27, 60). Permits installing heavy duty or next larger size battery. Adjustable height – No height limitations. Has selective bolt slots for straight across or diagonal type holddowns. 1/Bx

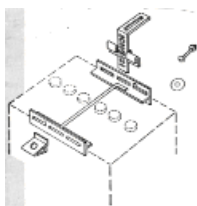

### DUAL PURPOSE BASE CLAMP BATTERY HOLDDOWN

Qual #: 20035

Dual purpose base clamp fits Ford base mounted battery groups. (29NF, 22F 1/Bx

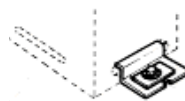

### 3-IN-1 BASE CLAMP BATTERY HOLDDOWN

Qual #: 20036

Three-in-one base clamp fits G.M. base mounted battery groups (24, 22C, 22F). Fits on side or end. 1/Bx

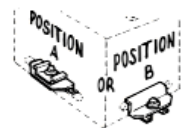

# Battery Accessories

## THE ELEKTRA LINK - BATTERY SLUG & TUBING SYSTEM

Elektralink system is the Sealed Solder Connection of the 21st century. Elektralink provides a fast, easy and environmentally sealed method to complete battery connections of all types. Elektralink is changing the way cable is linked so that users large & small, can have "A Perfect Connection". The Elektralink Battery Slug & Tubing system requires only a vise, cable stripper, and hand torch, which can be found in almost every workshop, making this exciting product available without high cost.

Assortments available: **LARGE METAL DRAWER** Qual #: A-1111

**SMALL PLASTIC BOX** Qual #: A-5111

Qual #	Gauge SAE	Color	Pkg.	BATTERY SOLDER SLUGS
M-900	4	Grey	50	 <p>Pre-measured pcs. of solder</p>
M-901	2	Green	50	
M-902	1	Pink	50	
M-903	1/0	Black	25	
M-904	2/0	Orange	25	
M-905	3/0	Purple	10	
M-906	4/0	Yellow	10	

## FLUX

Qual #: M-913

"No-Clean" flux for preparing cable for the soldering process. 2 oz. bottle. One unit per Pkg.



## MULTIPLE WALL TUBING ELEKTRALINK BATTERY TUBING

Multiple wall tubing with meltable adhesive liner. Provides superior environmental resistance to mechanical abuse, abrasion, water, salt, and other corrosive materials. Elektralink Battery Tubing is cut to special lengths for battery connections. Shrink ratio is 2.5:1.

Qual #	Gauge SAE	Length	Color
M-907	4	1.5"	Black
M-908	4	1/5"	Red
M-909	2, 1 & 1/0	1.5"	Black
M-910	2, 1 & 1/0	1.5"	Red
M-911	2/0, 3/0, & 4/0	2"	Black
M-912	2/0, 3/0, & 4/0	2"	Red



Packaged in units of 10

## UTILITY FLASHLIGHT

Qual #: 65091

Non conducting, high impact, heavy-duty plastic. Sure grip ribs and heavy-duty switch.



## RAYOVAC FLASHLIGHTS

Qual #: 65090

90° pivoting head. Comfort-Grip rubber handle and end caps provide comfort and durability. Impact absorbing rubber end cap and lens ring. Barrier wall and extra bulb holder. Full lifetime warranty. Non-roll design. Built-in hanging ring



## Duracell Products

### DURABEAM FLASHLIGHT

Qual #: 65080

More durable. Will withstand extreme abuse and all weather conditions. 50% Brighter Light. Lifetime Switch Warranty. Full 2-yr. Flashlight Warranty. Includes 2-Duracell "D" batteries.





### DURABEAM COMPACT LIGHT

Qual #: 65150

More dependable. Keeps on working after being dropped on concrete without a single dent. More Powerful Light. Full 2-yr. Warranty. Includes 2-Duracell "AA" batteries.



## ALKALINE BATTERIES (Qual # with "-C" indicates Coppertop)

AA	AAA	C	D	9V	6 VOLT	6 VOLT
Qual #: 65151 Qual #: 65151-C	Qual #: 65084 Qual #: 65084-C	Qual #: 65082 Qual #: 65082-C	Qual #: 65081 Qual #: 65081-C	Qual #: 65083 Qual #: 65083-C	Qual #: 65131	Qual #: 65121
						
For Calculators, Radios, Recorders, Flashlights.	For Calculators, Flashlights, Beepers, Photo, Toys.	For Radios, Photo, Recorders, Flashlights, Toys.	For Radios, Toys, Recorders, Flashlights, Photo.	Snap top for Radios, Calculators, Smoke Alarms, Photo, Toys.	Screw Top, H-D for Lights and Equipment.	Spring top for Lantern, Flashlights, Equipment.

## Wire & Cable

### PRIMARY WIRE

Color	6 GA	8 GA	10 GA	12 GA	14 GA	16 GA	18 GA
Red	15500	15504	15510	15515*	15525*	15535*	15545
Black	15501	15505	15511**	15516*	15526*	15536*	15546
White				15517	15527*	15537*	15547
Yellow				15518	15528*	15538*	15548
Brown				15519	15529*	15539*	15549
Blue		15506		15520	15530*	15540*	15550
Green				15521	15531*	15541*	15551
Purple				15522	15532*	15542	
Orange				15523	15533*	15543	
Gray					15534*	15544	
Mini Spools			15442	15441	15440	15439	15438

\*Add **M** suffix to these numbers for 1000 ft. Rolls

\*\*Add **L** suffix to these numbers for 500 ft. Rolls



### DUPLEX TWO CONDUCTOR WIRE

Qual #	Size	Length	Conductors
15560	16 GA	100 ft	2
15561	16 GA	1000 ft	2
15562	14 GA	100 ft	2
15563	14 GA	1000 ft	2
15564	12 GA	100 ft	2
15565	12 GA	1000 ft	2
15566	10 GA	100 ft	2



Duplex primary wire is made with two plastic insulated primary wires laid parallel and covered with a high quality plastic jacket, oblong in shape. The jacket provides a compact cable and protects the insulated conductors against weather and acid conditions. Each conductor is color coded. Sizes 12 and 10 gauge are recommended for electric brake wire.

### FLAT PARALLEL WIRE

Qual #	Size	Length	Conductors
15567	16/3	100 ft	3
15568	16/4	100 ft	4
15569	14/3	100 ft	3
15570	14/4	100 ft	4
15570-L	14/4	500 ft	4



Parallel copper primary wire is constructed of two, three or four standard wall primary wires extruded side by side so that the wires are held together by the thermoplastic insulation. Each conductor is color coded for identification purposes. The wires are easily separated. This parallel primary wire is very economical and convenient for use wiring assemblies and wherever a multiple conductor primary wire is needed.

### 3 & 4 CONDUCTOR WIRE

Qual #	Size	Length	Cond
15559	14GA	100 ft	4
15558	14GA	100 ft	3

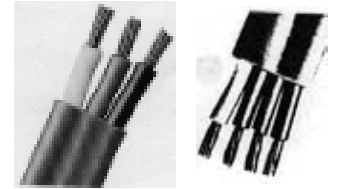

### TRAILER CABLE

Qual #	Cond	Gauge	Length
15575	4	14	50 ft
15576	4	14	100 ft
15576-1	4	14	1 ft
15577	6	14	50 ft
15578	6	14	100 ft
15578-1	6	14	1 ft
15579	7	1-10, 6-12	50 ft
15580	7	1-10, 6-12	100 ft
15580-1	7	1-10, 6-12	1 ft



100 ft rolls

- Conductors made of soft tinned annealed copper and color-coded to I.C.C. and A.T.A. standards.
- Highly flexible Neoprene rubber cover
- Resists acids, fuels and water
- Abrasion-proof
- Exceeds A.T.A. and S.A.E. specifications



# Wire & Cable

## BATTERY-STARTER CABLE

Qual #	Size	Color	Length	Cond. Stran	Cable O.D.
15690	4 Ga	Black	100 ft	49/ .0281	.440
15691	4 Ga	Black	50 ft	49/ .0281	.440
15692	4 Ga	Black	25 ft	49/ .0281	.440
15693	4 Ga	Red	100 ft	49/ .0281	.440
15694	4 Ga	Red	50 ft	49/ .0281	.440
15695	4 Ga	Red	25 ft	49/ .0281	.440
15696	2 Ga	Black	100 ft	84/ .0281	.440
15697	2 Ga	Black	50 ft	84/ .0281	.440
15698	2 Ga	Black	25 ft	84/ .0281	.440
15699	2 Ga	Red	100 ft	84/ .0281	.440
15700	2 Ga	Red	50 ft	84/ .0281	.440
15701	2 Ga	Red	25 ft	84/ .0281	.440
15702	1 Ga	Black	100 ft	133/ .0246	.440
15703	1 Ga	Black	50 ft	133/ .0246	.440
15704	1 Ga	Black	25 ft	133/ .0246	.440
15705	1 Ga	Red	100 ft	133/ .0246	.440
15706	1 Ga	Red	50 ft	133/ .0246	.440
15707	1 Ga	Red	25 ft	133/ .0246	.440
15708	1/0 Ga	Black	100 ft	133/ .0274	.530
15709	1/0 Ga	Black	50 ft	133/ .0274	.530
15710	1/0 Ga	Black	25 ft	133/ .0274	.530
15711	1/0 Ga	Red	100 ft	133/ .0274	.530
15712	1/0 Ga	Red	50 ft	133/ .0274	.530
15713	1/0 Ga	Red	25 ft	133/ .0274	.530
15714	2/0 Ga	Black	100 ft	133/ .0315	.610
15715	2/0 Ga	Black	50 ft	133/ .0315	.610
15716	2/0 Ga	Black	25 ft	133/ .0315	.610
15717	2/0 Ga	Red	100 ft	133/ .0315	.610
15718	2/0 Ga	Red	50 ft	133/ .0315	.610
15719	2/0 Ga	Red	25 ft	133/ .0315	.610
15720	3/0 Ga	Black	100 ft	259/ .025	.670
15721	3/0 Ga	Black	50 ft	259/ .025	.670
15722	3/0 Ga	Black	25 ft	259/ .025	.670
15723	3/0 Ga	Red	100 ft	259/ .025	.670
15724	3/0 Ga	Red	50 ft	259/ .025	.670
15725	3/0 Ga	Red	25 ft	259/ .025	.670
15726	4/0 Ga	Black	100 ft	359/ .375	.720
15727	4/0 Ga	Black	50 ft	359/ .375	.720
15728	4/0 Ga	Black	25 ft	359/ .375	.720
15729	4/0 Ga	Red	100 ft	359/ .375	.720
15730	4/0 Ga	Red	50 ft	359/ .375	.720
15731	4/0 Ga	Red	25 ft	359/ .375	.720



## CROSS-LINK POLY PRIMARY WIRE

Hi-temp automotive primary wire is insulated with chemically cross-linked Polyethylene and withstands prolonged temperatures of up to 350\* F. without melting or fusing. This new and versatile insulation has a smooth surface finish, comes in bright colors and operates satisfactorily between the extreme temperatures of -50\* to + 350\* Fahrenheit and -45\* to + 177\* Centigrade. It is highly resistant to grease, oil, acids, brake and abrasion. Recommended for use where high temperatures are encountered. Meets or exceeds S.A.E. Specification J1128.

Color	10 GA	12 GA	14 GA	16 GA	18 GA
Red	15452	15462	15472	15482	15492
Black	15453	15463	15473	15483	15493
White		15464	15474	15484	15494
Green		15465	15475	15485	15495
Blue		15466	15476	15486	15496
Yellow		15467	15477	15487	15497
Brown		15468	15478	15488	15498



## SELECTAKRIMP

Qual #: 19995

- One nest and indenter eliminates confusion
- Hammering on ram drives home a perfect connection each time
- Crimping scale on side of tool prevents under-crimping
- Nest design eliminates over-crimping
- Crimps non-insulated terminals.
- Splices battery cable lugs and solderless battery cable terminals

**Crimps**  
**#16 - 4/0 Ranges**

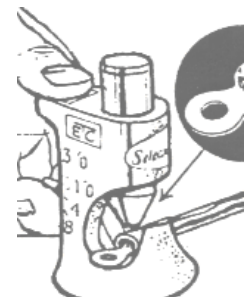
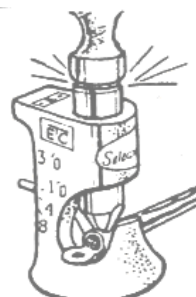
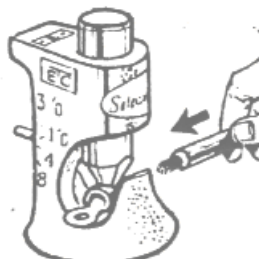
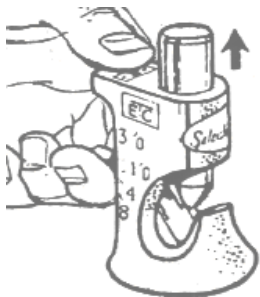

## Loom

### FLEX-GARD CONVOLUTED LOOM

Qual #	I.D.	Pkg.
15644	1 1/32"	100 ft
15645	1 1/32"	250 ft
15646	13/32"	100 ft
15647	13/32"	250 ft
15648	1/2	100 ft
15649	1/2	250 ft
15650	5/8	100
15651	5/8	2'
15655	3/4	50 ft
15654	1"	100 ft
15656	1-1/4"	100 ft

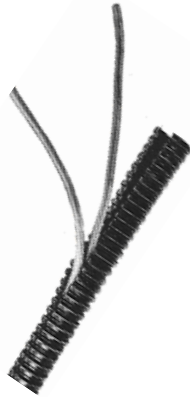

Black polyethylene convoluted loom holds groups of wires in position and gives the wires excellent protection against abrasion and crushing. It is slit for easy insertion of wires, yet the slit remains basically closed when the loom is bent or twisted. Temperature range of -30\* to +200\* F and -34\* to +93\* C.

### FABRIC LOOM

Qual #	I.D.	Pkg.
15620	1/4	50 ft
15621	5/16	50 ft
15622	3/8	50 ft
15623	7/16	50 ft
15624	1/2	50 ft
15625	5/8	50 ft
15626	3/4	50 ft

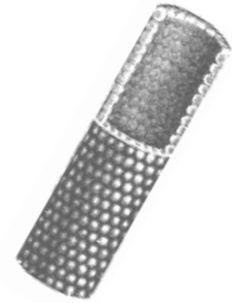

(-100) is 100 ft rolls

Woven cotton loom with black bituminous coating. Used for protection of wires, cables, air, and Hydraulic brake tubing, fuel lines, and control rods. Since loom is non-metallic it gives excellent protection against short circuits and undesirable noise.

## Tubing & Cable Clamps

Qual #	I.D.	Thickness	Bolt	VINYL COATED CABLE CLAMPS
20060	1/4	.025	1/4	
20060A	3/16			
20061	5/16	.025	1/4	
20062	3/8	.025	1/4	
20063	1/2	.025	1/4	
20064	5/8	.025	1/4	
20065	3/4	.025	1/4	
20066	1"	.025	1/4	
20067	1-1/4"	.025	1/4	

Qual #	Tube Size	Width	Thickness	NYLON CABLE CLAMPS
20270	1/4	3/8	.040	
20271	5/16	3/8	.040	
20272	3/8	3/8	.040	
20273	1/2	3/8	.040	
20274	5/8	3/8	.040	
20275	3/4	1/2	.040	
20276	1"	1/2	.040	

Qual #	I.D.	Thickness	Bolt	HEAVY DUTY CABLE CLAMPS
20260	1/4	.032	3/8	
20261	5/16	.032	3/8	
20262	3/8	.032	3/8	
20263	1/2	.048	3/8	
20264	5/8	.048	3/8	
20265	3/4	.048	3/8	
20266	1"	.048	3/8	
20267	1-1/4	.048	3/8	
20268	1-1/2	.048	3/8	

Qual #	I.D.	Bolt Hole	JIFFY CLAMPS
20042	1/4	3/16	
20043	5/16	3/16	
20044	3/8	3/16	
20045	1/2	3/16	
20046	5/8	3/16	
20047	3/4	3/16	

A-1247 Assortment

Qual #: 20051 1/4inch



Qual #: 20052 3/8"



Qual #: 20053 1/2inch



### CHASSIS CLAMPS

Made of Spring Steel- Snaps on Chassis to hold Cable, Loom, Tubing. 25 per Box Assortments A-1416 & A-1417 Available

# Bushings / Grommets

These Grommets or Snap Bushings are made of nylon and used to convert sharp edged metal holes to smooth neat insulated holes. They snap assemble with fingertip pressure and withstand 35 lb. pushback test.

Qual #	Mounting Hole Dia.	"A" Inside Dia.	"B" Head Dia.	"C" Height	Maximum Panel Thickness
M-32	.375	1/4	15/32	13/32	.125
M-33	.437	5/16	17/32	13/32	.125
M-34	.500	3/8	19/32	13/32	.125
M-35	.625	1/2	23/32	13/32	.125
M-36	.750	5/8	27/32	13/32	.125
M-37	1.000	3/4	1-1/8	29/64	.125
M-38	1.375	1"	1-1/2	29/64	.125

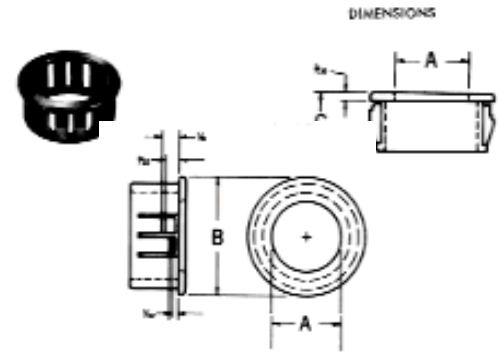

## RUBBER GROMMETS

Qual #	Size I.D.
20070	1/4
20071	5/16
20072	3/8
20073	1/2
20074	5/8
20075	3/4
A-1106	Assort.



## CHROME PLUG BUTTON

Qual #	Hole Size
30750	1/4
30751	3/8"
30752	1/2
30753	5/8"
30754	3/4
30756	1
1800	Assortment 25 of ea. # in plastic box



## FLUSH SHEET METAL PLUG

Qual #	Hole Size	Head Dia.
	3/8"	3/4
	1/2	7/8
	5/8"	1-3/64
38747	3/4	1



## FLEX EXPANSION PLUG

Qual #	Hole Size
31393	3/4
31394	7/8
31395	1"
31396	1-1/8"
31397	1-1/4"
31398	1-3/8"
31399	1-1/2"
31400	1-5/8"
31401	1-3/4"
31402	1-7/8"
31403	2"
31404	2-1/8"
31405	2-1/4"

### Features

- Slips in easily
- Can be finger-tightened
- Permanently set with one end wrench
- No metal comes in contact with coolant.
- Body of plugs resistant to heat, oil, antifreeze, rust inhibitors
- Expands as much as 1/8" to seal tightly against irregularities.
- Made of Neoprene.

If properly installed, a 2" plug will hold 50 lbs pressure without leakage. Smaller sizes will hold proportionately more pressure.



1. Reduce diameter of plug by making sure nut & washer are loose on plug bolt.

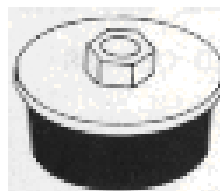

2. Insert plug in engine block as shown.



3. Turn nut clockwise causing plug to expand in engine block. In this expanded position, plug is tightly and permanently installed.

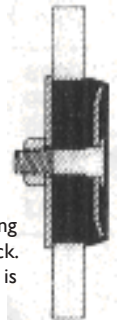

### STEEL EXPANSION PLUGS

Qual #	Size	Type	Pkg.
30937	1/2	CONCAVE	25
30938	5/8	CONCAVE	25
30939	3/4	CONCAVE	25
30940	7/8	CONCAVE	25
30941	15/16	CONCAVE	25
30942	1	CONCAVE	25
30943	1 - 1/16	CONCAVE	25
30944	1 - 1/8	CONCAVE	25
30945	1 3/16	CONCAVE	25
30946	1 - 1/4	CONCAVE	25
30947	1 - 3/8	CONCAVE	25
30948	1 - 1/2	CONCAVE	15
30949	1 - 5/8	CONCAVE	15
30950	1-3/4	CONCAVE	15
30951	2	CONCAVE	15
30952	7/16	CUP	25
30953	1/2	CUP	25
30954	17/32	CUP	25
30956	5/8	CUP	25
30957	3/4	CUP	25
30958	7/8	CUP	25
30960	1	CUP	25
30961	1 - 1/8	CUP	25
30962	1 - 7/32	CUP	15
30963	1 - 1/4	CUP	15
30964	1 - 3/8	CUP	15
30965	1 - 1/2	CUP	10
30966	1 - 5/8	CUP	10
30967	1 - 3/4	CUP	10
30968	1 - 7/8	CUP	10
30969	1 - 15/16	CUP	10
36322	1 - 49/64	SHALLOW CUP	10
30970	1 - 61/64	CUP	10
30971	2	CUP	10
30972	1 - 31/32	SHALLOW CUP	10
30973	2 - 1/16	SHALLOW CUP	10

FOR AN ASSORTMENT OF EXPANSION PLUGS,  
SEE KITS #A-1016 & A-1017



**CONCAVE TYPE**



**CUP TYPE**

### DRAIN PLUGS

Qual #	Size	Pkg
19928	1/2 Stand.	10
19929	5/8 Stand	6
19936	1/2 O.S.	10
19937	1/2 D.O.	10



### DRAIN PLUG ASSORTMENT Qual #: 19935

### GASKETS

Qual #	Size	Material	Pkg
19924	1/2 Stand.	Nylon	25
19925	5/8 Stand.	Nylon	25
19926	7/8 Stand.	Nylon	25
19927	1/2 Stand.	Fibre	25
19930	1/2 O.S.	Fibre	25
19931	1/2 D.O.	Fibre	25
19932	5/8 O.S.	Fibre	25
19933	7/8 O.S.	Fibre	25



### FIBRE GASKET ASSORTMENT Qual #: 19938

Seven different size gaskets for standard and oversize drain plugs. Gasket fibre of High tensile strength and long life. Colored for ease of identification. (125 gaskets)

### SPECIAL OIL DRAIN PLUGS

Qual #: 20115 (1/2 size), Qual #: 20116 (5/8 size)

5 per Package with 1 inserting tool



### FEATURES

- Withstands temperatures of 70 below zero to 260 above.
- Not affected by engine Oil, Acids, Sludge, Water.
- Cannot come loose. Eliminates oil leak due to damaged or stripped crankcase drain hole.

### INSTALLATION:

- 1) Reduce the diameter of the plug by inserting tool and locking in stretched position.
- 2) Insert plug into prepared crankcase hole.
- 3) Remove tool. Plug expands into the hole.

*NOTE: to remove, just insert tool lock in stretched plug and remove.*

### METAL SELF TAPPING OIL DRAIN PLUG

Qual #	Plated	Size	Details	Pkg
20117	Plated	1/2-20	Oversize w/Pipe Plug Oversize Oil Drain Plug	5
20118	Plated	1/2-20	Double Oversize w/Pipe Plug Oversize Oil Drain Plug	5



### One Time Repair For Stripped Threads in Oil Pan

Puts An End To:

- Further pan thread damage
- Costly oil pan replacement
- Leaking drain plug.

# Pigtail Sockets

## HEADLIGHT CONNECTORS

Sealed beam headlight or directional signals on most cars, trucks and many other electrical applications. UNIT Package 5



**Qual #:** 19989  
3-wire unit for 6 or 12 volt systems; 12" leads (stripped 1/4") of #16 wire.



**Qual #:** 19990  
2-wire unit for 12 volt system; 12" leads (stripped 1/4") of #16 wire.

## VOLTAGE REGULATOR PIGTAIL

**Qual #:** 19964  
All General Motors Cars – '65-'78  
UNIT Package 1

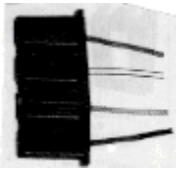

**Qual #:** 19965  
All Ford Products – '67-'78  
UNIT Package 1

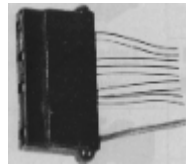

## DIMMER SWITCH PIGTAIL

**Qual #:** 19971  
General Motors Products: '65 – '77  
UNIT Package 5

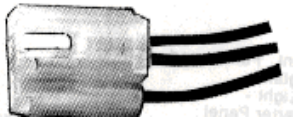

**Qual #:** 19972  
Chrysler Products – Voltage Regulator  
General Motors – Temperature  
Sending Unit  
UNIT Package 10

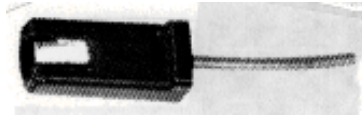

**Qual #:** 19984  
4 Pole Female Conn w/12" Leads Flat  
Molded Type UNIT Package 5



**Qual #:** 19985  
4 Pole Male Conn w/12" Leads Flat  
Molded Type UNIT Package 5



## ALTERNATOR PIGTAIL

**Qual #:** 19969  
All General Motors Products – '65-'77  
UNIT Package 5



**Qual #:** 19970  
All General Motors Products -  
w/ Transistorized Alternators  
UNIT Package 5



## INSTRUMENT PANEL AND MARKER LIGHT PANEL

**Qual #:** 19945  
Marker Light - rear quarter panel  
General Motors & Ford '69 - '77  
Instrument Panel Sockets - General  
Motor Cars  
UNIT Package 1



## TAIL LIGHT SOCKET ASSEMBLY

**Qual #:** 37659  
Molded Plastic w/ Waterproof  
Rubber "O" Ring at bulb. 8"  
Wire Leads 7/8" Focal Length  
Chevrolet & Pontiac



## TURN SIGNAL

**Qual #:** 19966  
Replaces GM 8903283, 8909908, and 8902487.  
UNIT Package 1



**Qual #:** 19976  
Heat element on engine block  
for Ford and American Motors;  
other universal applications.  
Molded right angle plug  
receptacle crimped to single  
12" lead (stripped 1/4")  
UNIT Package 10



**Qual #:** 19988  
2 Pole Male/Female w/12" Leads  
UNIT Package 5



## AIR CONDITIONER BLOWER RELAY

**Qual #:** 19973  
All General Motors Products - '65 - '77  
UNIT Package 5

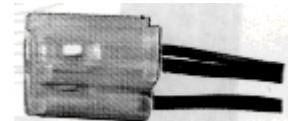



## Pigtail Sockets

### DIMMER SWITCH PIGTAIL

Qual #: 19974  
Ford Products - '60 - '77  
Chrysler Products - '59 - '77  
UNIT Package 5

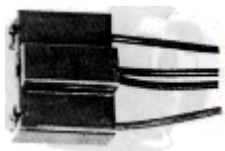

### PIGTAIL CONNECTOR

Qual #: 19980 (USE WITH 19981)  
Single Wire Lead 12" Long Receptacle for use wherever there is a junction of two or more wires; such as behind an instrument panel or in an engine compartment.  
UNIT Package 10



### PIGTAIL CONNECTOR

Qual #: 19981 (USE WITH 19980)  
Single Wire Lead 12" Long Snap Plug for use wherever there is a junction of two or more wires; such as behind an instrument panel or in an engine compartment.  
UNIT Package 10



### MOLDED TYPE

Qual #: 19986  
3 Pole Female Conn w/12" Leads Flat  
UNIT Package 5



Qual #: 19987  
3 Pole Male Conn w/12" Leads Flat  
UNIT Package 5



### PIGTAIL & SOCKET ASSEMBLY

Qual #: 39599  
Double Contact with Ground - Chrysler, Dodge, Plymouth '71-'82  
UNIT Package 1

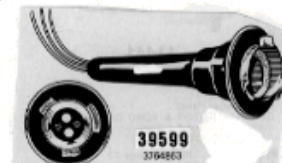

### BACK-UP LIGHT ASSEMBLY

Qual #: 38156  
Molded Vinyl Housing 2 Wires - Brown 9-1/2" and Green 9-1/4" Use GE 1156 Bulb  
UNIT Package 1

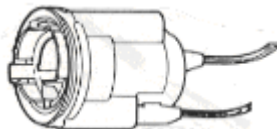

### PARKING, TAIL & STOP LIGHT ASSEMBLY

Qual #: 38161  
Molded Vinyl Housing 3 Wires - Black 11-1/2", Yellow 11-1/4", Brown 11-1/4" Focal Length 7/8" Use GE 1157 Bulb  
UNIT Package 1

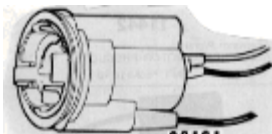

### SNAP-IN SOCKET ASSEMBLY

Qual #: 35759  
For double indexed bulbs. Double Wire Lead 12" Long Replaces Parking, Directional, Tail or Stop Light Holders - Buick, Cadillac, Rambler or Willys.  
UNIT Package 5

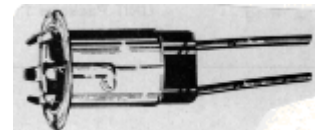

### INSTRUMENT PANEL LIGHT ASSEMBLIES

Qual #: 35761  
Instrument panel lighting on Ford cars. Completely insulated housing; 12" lead (stripped 1/4") of #16 stranded wire (AWG); for bulbs 51, 53, 55, 57 and 57X.  
UNIT Package 5



Qual #: 19963  
Instrument panel lighting on '63-'67 Chrysler cars (#2496279) and on '66-'67 Chevrolets (#2973932). Snaps into recess of instrument panel interior. Socket's two copper points make contact with the wire ends of the panel. Uses GE bulb #158.  
UNIT Package 1



### 90° PIGTAIL & SOCKET ASSEMBLY

Qual #: 39600 (12003759)  
GM Products '77-'82; All Models with 90° Socket Chevy, GMC, CKGP 1,2,3  
UNIT Package 1

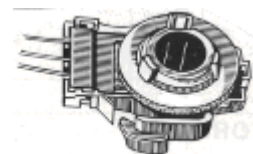

### SIX WAY TRAILER CONNECTOR

Qual #: 38434  
6 Color Coded Wire Leads (Male)  
For Trailer Application  
UNIT Package 5

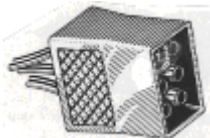

Qual #: 38435  
6 Color Coded Wire Leads (Female)  
For Trailer Application  
UNIT Package 5



### FLASHER PIGTAIL

Qual #: 39751  
Wire Size 14 Ga; Wire Lead Length 6"  
GM Product Universal Application  
All Popular 2 Terminal Flashers Std. & HD  
UNIT Package 5





# Pigtail Sockets

## PIGTAIL SOCKETS

Qual #: 19947

Has single 12" lead (stripped 1/4") of #16 stranded wire (AWG); used with miniature lamp #'s 51,53,55,57 and 57X.



Qual #: 19952

Has single 12" lead (stripped 1/4") of #16 stranded wire (AWG); used with standard contact lamp #'s 63, 67, 81, 87, 89, 93, 209, 1003, 1073, 1129, 1133, 1141



Qual #: 19955

Tail light and directional signals on GM trucks. Molded plastic housing; 8" double leads (stripped 1/4") of #16 stranded wire (AWG).



Qual #: 19953

Has double 12" leads (stripped 1/4") of #16 stranded wire (AWG); used with aligned contact lamp #'s 64, 68, 82, 88, 90, 94, 210, 1004, 1074, 1130, 1158, 1176



Qual #: 19954

Has double 12" leads (stripped 1/4") of #16 stranded wire (AWG); used with double contact indexed lamp #'s 1034, 1154, 1157



Qual #: 19951

Has molded plastic housing to protect contact points against moisture; 12" leads (stripped 1/4") of #16 wire. Used with double contact indexed lamps 1034 and 1154. Fits 3/4" to 1-1/8" holes.



Qual #: 19957

Rear directional, stop, tail and parking lights for GM cars, trucks, trailers. Sealed socket lamp assembly has 30" lead (stripped 1/4") with insulated male tab terminal and 11" sealed plastic boot; snaps in 3/4" diameter hole; used with single contact lamp #'s 63, 67, 81, 87, 93, 209, 1003, 1073, 1129, 1133 and 1141.



## SEALED SOCKET ADAPTER PLATE

Qual #: 19958 with plate

Used to mount snap-in type lamp socket when light fixture is rusted out.

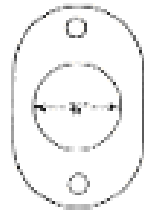

Qual #: 19958

Rear directional, stop, tail and parking lights for GM cars, trucks, trailers, 30" leads (stripped 1/4") with insulated male tab terminals and 11" sealed plastic boot; snaps in 3/4" diameter hole; used with double contact indexed lamps 1034 and 1154.

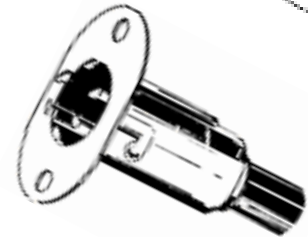

## TAIL AND STOP LIGHTS

Qual #: 19960

Tail and Stop Lights on late model GM cars. Hard plastic "grip lock" housing with sealed-in blade contacts. Single Contact. UNIT Package I



Qual #: 19961

Tail and Stop Lights on late model GM cars. Hard plastic "grip lock" housing with sealed-in blade contacts. Double Contacts. UNIT Package I



## PARKING, TAIL & STOP LIGHT ASSEMBLY

Qual #: 19967

GM Cars '69-'78 Use GE bulb #1157; Molded Vinyl Housing - 3 Wires Black 11-1/2", Yellow 11-1/4" & Brown 11-1/4" Focal Length 7/8" UNIT Package I

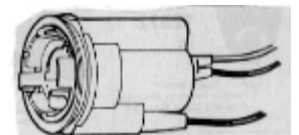

## Clamps

### WORM DRIVER CLAMPS

- One piece stainless steel housing  
NO Rivets - NO Welds
- 1/2" Wide band has smooth edges  
Will not cut hose
- Worm drive screw slot.
- 5/16 Hex head & slot.
- Use either wrench or screwdriver
- Exceeds all sae requirements

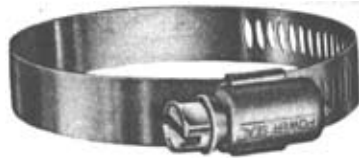

### MINIATURE CLAMPS

Lightweight, streamlined clamp generally used for small (under 1") diameters. Can handle pressures up to 1000 p.s.i. with less than 15 inch pounds of torque.



Qual #	Size	Fits Hose I.d.	Pkg	Application	Effective Range
24940	4	3/16 - 1/4 - 5/16	25	Fuel Hose	7/32 5/8
24941	5 - 6	1/4 - 3/8 - 1/2	25	Fuel Hose	7/16 25/32
24942	6	1/4 - 3/8 - 1/2	25	Air Line Hose	7/16 25/32
24943	10	5/8 - 3/4 - 7/8	25	Heater Hose	9/16 1 1/16
24944	12	3/4 - 7/8 - 1	25	Heater Hose	1 1/16 1 1/4
24945	16	1 - 1 1/8 - 1 1/4	25	Heater Hose	1 3/16 1 1/2
24946	20	1 - 1 1/8 - 1 1/4 - 1 1/2	25	Radiator Hose	1 3/16 1 3/4
24947	24	1 1/4 - 1 1/2 - 1 3/4	25	Radiator Hose	1 1/16 2
24948	28	1 1/2 - 1 5/8 - 1 3/4 - 2	25	Radiator Hose	1 5/16 2 1/4
24949	32	1 7/8 - 2 - 2 1/8	25	Radiator Hose	1 9/16 2 1/2
24950	36	2 - 2 1/4	25	Radiator Hose	1 13/16 2 3/4
24951	40	2 1/2 - 2 3/4	10	Radiator Hose	2 1/16 3
24952	44	2 5/8 - 2 3/4 - 2 7/8	10	Radiator Hose	2 5/16 3 1/4
24953	48	3 - 3 1/4	10	Radiator Hose	2 9/16 3 1/2
24954	56	3 1/2 - 3 3/4	10	Radiator Hose	3 1/16 4
24955	64	4 - 4 1/4	10	Radiator Hose	3 9/16 4 1/2
24956	72	3 7/8 - 4 3/4	10	Radiator Hose	4 1/8 5
24957	88	4 3/4 - 5 3/4	10	Radiator Hose	5 1/8 6
24958	104	6 1/8 - 6 3/4	10	Radiator Hose	6 1/8 7

### LINER CLAMPS FOR SOFT/SILICONE HOSE

Qual #	Size	Pkg	Effective Range
24959	6	10	9/16 13/16
24959a	8	10	1 1/16 1 5/16
24960	10	10	1 3/16 1 1/16
24961	12	10	1 5/16 1 1/4
24962	16	10	1 3/16 1 1/2
24964	20	10	1 1 1/4
24966	24	10	1 3/16 2
24967	28	10	1 5/16 2 1/4
24969	32	10	1 9/16 2 1/2
24971	36	10	1 13/16 2 3/4
24975	44	10	2 5/16 3 1/4

### WIRE HOSE CLAMP

For H057 Hose Only

Qual #	Hose I.d.
18955	3/16, 1/4



### CLAMP ASSORTMENT WITH RACK

Qual #: 24930 (10012 Rack Only)

Qty.	Size
10	#4 Mini
10	#6 Mini
10	#10
10	#12
10	#16
10	#20
10	#28
10	#32
10	#36

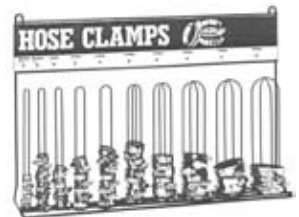

### MAKACLAMP

Readily Provide Adjustable, 100% Stainless Clamps in Diameters from 2 inches to Many Feet. MakAclamp parts consist of a roll of specially perforated 300 Series stainless band that can be cut to required length; and stainless, adjustable fastener assemblies with 410 stainless steel 5/16" HEX screws, bright hardened and passivated, They quickly interlock to form any size clamp to hold things together, secure things on, or hang things up.

Qual #	Kit	Band	Fast.	Splice
M-363	Mini Kit	8-1/2 ft band	3 adj. Fasteners	1 band splice
M-365	Kit	100 ft band	25 adj. Fasteners	10 band splices



# Plated Rollpins

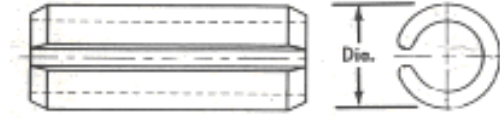









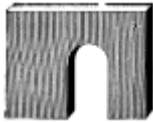

Qual #	Size	Wall Thick	Pkg
35981	1/16x3/16	.062	50
35982	1/16x5/16	.062	50
35983	1/16x1/2	.062	50
35985	1/16x3/4	.062	50
35986	1/16x7/8	.062	50
35987	1/16x1"	.062	50
35988	5/64x1/4	.078	50
35989	5/64x1/2	.078	50
35990	5/64x9/16	.078	50
35991	5/64x3/4	.078	50
35992	5/64x1"	.078	50
35993	5/64x1-1/4	.078	50
35994	5/64x1-1/2	.078	50
35995	3/32x5/16	.094	50
35996	3/32x1/2	.094	50
35997	3/32x5/8	.094	50
35998	3/32x3/4	.094	50
35999	3/32x7/8	.094	50
36000	3/32x1"	.094	50
36001	3/32x1-1/4	.094	50
36002	3/32x1-1/2	.094	50
36003	1/8 x3/8	.125	50
36004	1/8 x1/2	.125	50
36005	1/8 x5/8	.125	50
36006	1/8 x3/4	.125	50
36007	1/8 x7/8	.125	50
36008	1/8 x1"	.125	50
36009	1/8 x1-1/4	.125	50
36010	1/8 x1-1/2	.125	50
36011	1/8 x1-3/4	.125	50
36012	1/8 x2"	.125	25
36013	5/32x1/2	.156	50
36014	5/32x5/8	.156	50
36015	5/32x3/4	.156	50
36016	5/32x1"	.156	50

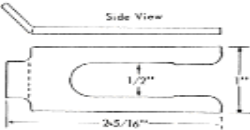
Qual #	Size	Wall Thick	Pkg
36017	5/32x1-1/4	.156	50
36018	5/32x1-1/2	.156	25
36019	3/16x1/2	.187	50
36021	3/16x3/4	.187	50
36022	3/16x1"	.187	25
36023	3/16x1-1/4	.187	25
36024	3/16x1-1/2	.187	25
36025	3/16x1-3/4	.187	25
36026	3/16x2"	.187	25
36027	7/32x5/8	.219	25
36027A	7/32x1		25
36028	7/32x1-3/8	.219	25
36029	7/32x1-3/4	.219	25
36030	1/4 x5/8	.250	25
36031	1/4 x3/4	.250	25
36032	1/4 x7/8	.250	25
36033	1/4 x1"	.250	25
36034	1/4 x1-1/4	.250	25
36035	1/4 x1-1/2	.250	25
36036	1/4 x1-3/4	.250	25
36037	1/4 x2"	.250	25
36038	1/4 x2-1/4	.250	25
36039	1/4 x2-1/2	.250	25
36040	5/16x3/4	.312	25
36041	5/16x7/8	.312	25
36042	5/16x1"	.312	25
36043	5/16x1-1/2	.312	25
36044	5/16x1-3/4	.312	25
36045	5/16x2"	.312	15
36046	5/16x2-1/2	.312	15
36047	3/8 x3/4	.375	25
36048	3/8 x1"	.375	15
36049	3/8 x1-1/2	.375	15
36050	3/8 x2"	.375	15
36051	3/8 x2-1/2	.375	10
36055	1/2 x 3-1/2		10

ROLLPIN ASSORTMENT SEE: A-1236 & A-1237

## Body & Front End Shims

Qual #	Thickness	Slot	
30155	1/16"	3/8	
30156	1/8"	3/8	
32089	1/32"	7/16	
32090	1/16"	7/16	
32091	1/8"	7/16	
29452	1/16"	7/16	
29453	1/8"	7/16	
32074	1/64"	1/2	
32075	1/32"	1/2	
32076	1/16"	1/2	
32077	1/8"	1/2	
37705	1/16"	1/2	
37706	1/8"	1/2	

Qual#	Thickness	Slot	
32093	1/32"	9/16	
32094	1/16"	9/16	
32095	1/8"	9/16	
32096	1/32"	9/16	
32097	1/16"	9/16	
32098	1/8"	9/16	
32099	3/16"	9/16	
32079	1/64"	9/16	
30000	1/8"	3/4	
30158	1/16"	3/4	

## Clevis Pin

### UNIVERSAL-PLATED

PKG 10



Qual #	Size	Use Cotter Dia.
2130	1/4 x 2"	3/32
2131	5/16 x 2"	3/32
2132	3/8 x 2"	3/32
2133	7/16 x 2"	3/32
2134	1/2 x 2"	1/8
2135	1/2 x 2-1/2"	1/8
2136	1/2 x 3"	1/8
2137	5/8 x 3"	1/8

Asst #  
 A-1070 Small  
 33060 Large

### DRILLED FOR COTTER PINS-PLATED

PKG 25



Qual #	Dia.	Lgth. Under Head to Center Hole	Lgth. Under Head to End of Pin	Cotter Pin Size
36433	1/4	29/32	1"	1/16
36434	1/4	1"	1-1/8	1/16
36435	5/16	7/8	1"	3/32
36436	5/16	1"	1-1/8"	3/32
36437	5/16	1-1/8"	1-1/4"	3/32
36438	5/16	1-1/4"	1-3/8"	3/32
36439	5/16	1-5/8"	1-3/4"	3/32
36440	3/8	7/8"	1"	3/32
36441	3/8	1"	1-1/8"	3/32
36442	3/8	1-1/16"	1-3/16"	3/32
36443	3/8	1-1/8"	1-1/4"	3/32
36444	3/8	1-3/8"	1-1/2"	3/32
36445	3/8	1-5/8"	1-3/4"	3/32
36446	1/2	1-11/32"	1-1/2"	1/8
36447	1/2	1-19/32"	1-3/4"	1/8

Asst # Clevis Pins 33139 Cotter Pins 33112

# Quality Regular and Coated Wheel Weights

## COATED WHEEL WEIGHTS

Coated wheel weights for alloy wheels have a special dry polymer coating that prevents the wheel from being stained by the weight. They are designed to meet or exceed all oem spec. To protect the finish from lead staining for the life of the vehicle. To avoid damage to the coating, a soft headed hammer, no. 75K or equivalent, should be used to install these weights. Our unique "window barb" clip design prevents the weight from being pushed off the wheel.

### C TYPE / REG SERIES

For All Passenger Cars except where FD Type or CV Weights are required.

Qual.#	Size/oz	Pkg
24840	1/4	50
24841	1/2	50
24842	3/4	50
24843	1	50
24844	1-1/4	50
24845	1-1/2	50
24846	1-3/4	50
24847	2	25
24848	2-1/4	25
24849	2-1/2	25
24850	2-3/4	25
24851	3	25
24852	3-1/4	25
24853	3-1/2	25
24854	3-3/4	25
24855	4	25



Wts. 6oz available, Special order #24859

### CV TYPE / AW SERIES

For Original Equipment Alloy Wheel (-C # = AWN/AWS )

Qual.#	Size/oz	Pkg	Coated #
24866	1/4	50	24866-C
24867	1/2	50	24867-C
24868	3/4	50	24868-C
24869	1	25	24869-C
24870	1-1/4	25	24870-C
24871	1-1/2	25	24871-C
24872	1-3/4	25	24872-C
24873	2	25	24873-C
24874	2-1/4	25	24874-C
24875	2-1/2	25	24875-C
	2-3/4	25	24875A-C
24876	3	25	24876-C



### ADHESIVE TYPE WEIGHTS

For All Passenger Cars & Trucks

**Qual #:** 24820  
3/4" Racing - 3/4" Wide x .100 Thick x 12" Long. #24820 contains 30 twelve inch lengths. One length weights 6 oz.. Marked in 1/4 oz. segments

**Qual #:** 24820-12 15 six inch strips in 1/2 oz segments



## Spoke Wheel Hardware

### RIM CLAMP NUT Bx/25

11790	5/8-11
11791	3/4-10



### RIM STUD GR8 Bx/10

11792	5/8-11x2-3/4
11793	3/4-10x3



### DOMESTIC VEHICLES

Qual.#	OZ.	Pkg	FORD	EXPLORER	CHRYSLER
24900	1/4	50	24900-C	24900-EX	24828-C
24901	1/2	50	24901-C	24901-EX	24829-C
24902	3/4	50	24902-C	24902-EX	24830-C
24903	1	25	24903-C	24903-EX	24831-C
24904	1 1/4	25	24904-C	24904-EX	24832-C
24905	1-1/2	25	24905-C	24905-EX	24833-C
24906	1-3/4	25	24906-C	24906-EX	
24907	2	25	24907-C	24907-EX	24835-C
24908	2 1/4	25	24908-C	24908-EX	
24909	2-1/2	25	24909-C	24909-EX	
24910	2-3/4	25	24910-C	24910-EX	
24911	3	25	24911-C	24911-EX	



"AW" Type Coated  
Avail. 1/2oz.- 3oz. # 24860-24865

"LT1" Type Light Truck wt.  
Avail. 1/2oz - 5oz #24877-24885

"I-7" (E Series) Type  
Avail. 2oz - 16oz #24887-24896

All Regular # as noted / **IW**  
All Coated # bx 25 / **MC**  
All Explorer # bx 25 / **TS**  
All Chrysler # bx 25 / **LH**

### IMPORTED VEHICLES

Qual #	Size	Pkg
24866-I	10 GR	50
24867-I	15 GR	50
24868-I	20 GR	50
24868A-I	25 GR	25
24869-I	30 GR	25
24870-I	35 GR	25
24870A-I	40 GR	25
24871-I	45 GR	25
24872-I	50 GR	25
24873-I	55 GR	25

### WTS LEXUS/TOYOTA

24920	5 GR	25
24921	10 GR	25
24922	15 GR	25
24923	20 GR	25
24924	25 GR	25
24925	30 GR	25
24926	35 GR	25
24927	40 GR	25
24928	45 GR	25
24929	50 GR	25
24929-A	55 GR	25



## Universal Springs

### CARBURETOR AND STARTER PEDAL SPRINGS



- Qual # 20094 contains 24 pcs.
- Qual # 20095 contains 12 pcs. 20094 & 12pcs 20097

### CARBURETOR HELPER SPRING



- Qual # 20097 contains 24 pcs.

### CARBURETOR RETURN SPRING Heavy Duty – Universal



- Qual # 20096 contains 20 pcs.

### UNIVERSAL PEDAL RETURN SPRINGS for CLUTCHES & BRAKES



- Qual # 20090 contains 16 pcs.
- Qual # 20091 contains 16 pcs.
- Qual # 20093 contains 8 pcs. 20090 & 8 pcs 20091

### UNIVERSAL SPRINGS & ASSORTMENT - Hook Ends, Loop Ends

- Qual # 20092 contains 20 Assorted Springs



## Ball Joints

### BALL JOINT ASSEMBLY

- Qual #: 36869
- 3/8-24 Male & Female Thread.
- Automotive Use. Pkg. 5
- GENERAL PURPOSE



- Qual #: 36870
- 1/-4-28 SAE Male Female Thread.
- Pontiac, Ford, Olds, Lincoln, Mercury, and GMC Trucks.
- Pkg 5



### BALL JOINT ASSEMBLIES

- Male & Female Thread
- Spring Loaded.
- Automotive Use. Pkg 5



- | Qual # | Thread Size |
|--------|-------------|
| 36866  | 10-32 SAE   |
| 36867  | 1/4--28 SAE |
| 36868  | 5/16-24 SAE |

### ADJUSTABLE BALL JOINT ASSEMBLIES

- Male Female Thread Pkg. 5

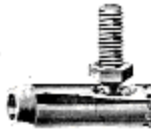

- | Qual # | Thread Size |
|--------|-------------|
| 36872  | 1/4-28 SAE  |
| 36873  | 5/16-24 SAE |

### FLAT TOP "SHURSEAL"

- Ball Joint Assembly Pkg 1



- | Qual # | Thread Size |
|--------|-------------|
| 39043  | 1/2-20 SAE  |

## Yoke Ends

### SELF-COLORED DROP FORGED YOKE ENDS

ADJUSTABLE DIMENSIONS IN INCHES

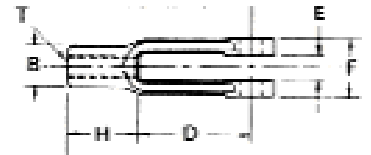
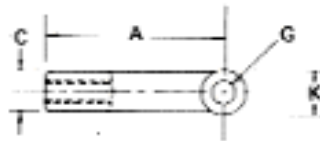

Qual #	"T" Tap Size	A	B	C	D	E	F	G	H	K	Pkg
37737	1/4-28	2	7/16	7/16	1-1/4	9/32	5/8	1/4	3/4	1/2	10
37788	1/4-28	2	7/16	7/16	1-1/4	9/32	5/8	1/4	3/4	1/2	2
37738	5/16-24	2-1/4	1/2	1/2	1-7/16	11/32	3/4	5/16	13/16	19/32	10
37789	5/16-24	2-1/4	1/2	1/2	1-7/16	11/32	3/4	5/16	13/16	19/32	2
37739	3/8-24	2-1/2	5/8	5/8	1-5/8	7/16	7/8	3/8	7/8	11/16	10
37790	3/8-24	2-1/2	5/8	5/8	1-5/8	7/16	7/8	3/8	7/8	11/16	2
37740	7/16-20	2-7/8	23/32	23/32	1-7/8	1/2	1	7/16	1	13/16	10
37791	7/16-20	2-7/8	23/32	23/32	1-7/8	1/2	1	7/16	1	13/16	2
37741	1/2-20	3	13/16	13/16	1-7/8	9/16	1-1/8	1/2	1-1/8	15/16	10
37792	1/2-20	3	13/16	13/16	1-7/8	9/16	1-1/8	1/2	1-1/8	15/16	2
37742	5/8-18	4-15/16	1-1/16	1-1/16	3-11/16	11/16	1-3/8	5/8	1-1/4	1-3/16	10
37793	5/8-18	4-15/16	1-1/16	1-1/16	3-11/16	11/16	1-3/8	5/8	1-1/4	1-3/16	2



## Rubber "O" Rings

Qual #	Inside Dia.	Outside Dia.	Thickness	Unit Pkg.
31305	1/8	1/4	1/16	10
31306	5/32	9/32	1/16	10
31307	3/16	5/16	1/16	10
31308	7/32	11/32	1/16	10
31309	1/4	3/8	1/16	10
31310	5/16	7/16	1/16	10
31311	3/8	1/2	1/16	10
31312	3/8	9/16	3/32	10
31313	7/16	5/8	3/32	10
31314	1/2	11/16	3/32	10
31315	9/16	3/4	3/32	10
31316	5/8	13/16	3/32	10
31317	11/16	7/8	3/32	10
31318	3/4	15/16	3/32	10
31319	3/4	1"	1/8	10
31320	13/16	1-1/16	1/8	10
31321	7/8	1-1/8	1/8	10
31322	15/16	1-3/16	1/8	10
31323	1"	1-1/4	1/8	10
31324	1-1/16	1-5/16	1/8	10
31347	1-1/8	1-3/8	1/8	10
31348	1-3/16	1-7/16	1/8	10
31349	1-1/4	1-1/2	1/8	10
31350	1-5/16	1-9/16	1/8	10
31351	1-3/8	1-5/8	1/8	10
31352	1-7/16	1-11/16	1/8	10
31353	1-1/2	1-3/4	1/8	10
31354	1-1/2	1-7/8	13/64	10
31355	1-5/8	2"	13/64	10
31356	1-3/4	2-1/8	13/64	10
A-1253	"O" Ring Assortment			

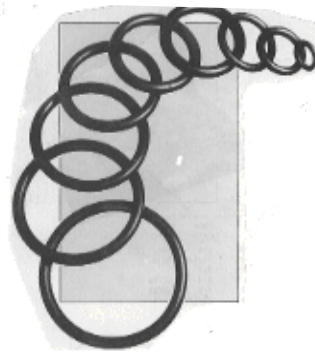

### METRIC BUNA "N" RUBBER "O" RINGS Bx 10

Qual #	Inside Dia.	Outside Dia.	Thickness
31304M	5mm	8mm	1.5mm
31305M	5.3mm	10.1mm	2.4mm
31306M	5.6mm	10.4mm	2.4mm
31307M	6mm	10mm	2mm
31308M	7.1mm	10.3mm	1.6mm
31309M	7.6mm	12.4mm	2.4mm
31310M	8mm	12mm	2mm
31311M	8.3mm	13.1mm	2.4mm
31312M	8.6mm	13.4mm	2.4mm
31313M	9mm	13mm	2mm
31314M	9mm	15mm	3mm
31315M	9.1mm	12.3mm	1.6mm
31316M	10mm	14mm	2mm
31317M	10mm	15mm	2.5mm
31318M	10mm	16mm	3mm
31319M	10.1mm	13.3mm	1.6mm
31320M	11mm	17mm	3mm
31321M	12mm	16mm	2mm
31322M	13mm	16mm	1.5mm
31323M	13mm	18mm	2.5mm
31324M	13.1mm	16.3mm	1.6mm
31347M	14mm	18mm	2mm
31348M	14mm	19mm	2.5mm
31349M	15mm	20mm	2.5mm
31350M	16mm	19mm	1.5mm
31351M	16mm	20mm	2mm
31352M	17mm	22mm	2.5mm
31353M	18mm	23mm	2.5mm
31354M	19mm	23mm	2mm
31355M	19mm	24mm	2.5mm
31356M	20mm	24mm	2mm
A-1253M	Metric "O" Ring Assortment		

## Hose and Tubing

Qual #	Size	Amt
2070	1/2	50 ft
2071	5/8	50 ft
2072	3/4	50 ft
2073	1	50 ft

### STANDARD BLACK HEATER HOSE

Constructed for general service on most cars and light truck applications. Black E.P.D.M. tube and cover designed to resist ozone and engine heat. High quality inner tube handles coolant solutions and additives. Reinforced for high strength and resistance to kinking and swelling. Manufactured to meet S.A.E. 20R3 class D2.



Qual #	Size	Amt
2074	1/2	50 ft
2075	5/8	50 ft
2076	3/4	50 ft

### AUTO-PAR SUPERIOR RED HEATER HOSE

Quality E.P.D.M. tube and cover heater hose gives maximum service life. EPDM cover is ozone and heat resistant for higher under-hood temperatures. EPDM tube is especially compounded not to soften, swell or flake. Handles corrosive additives and coolant solutions. Synthetic cord reinforced. Manufactured to meet S.A.E. 20R3 class D2.



Qual #	Size	Amt
2080	3/16	25 ft
2081	1/4	25 ft
2082	5/16	25 ft
2083	3/8	25 ft
2084	7/16	25 ft

### FUEL LINE PLUS HOSE

Hypalon cover and Nitrile tube provides superior performance against leaded, unleaded, diesel and gasohol fuels. Meets O.E.M. requirements and SAE J30R7 specifications. Ideal for emission control hose applications. Resists heat up to 257°F, oil grease and ozone. Not suitable for fuel injection systems.



Qual #	Size	Amt
2020	3/32	50 ft
2086	7/64 (1/8)	50 ft
2085	1/8	25 ft
2087	5/32 (3/16)	50 ft
2088	7/32 (1/4)	50 ft

### WINDSHIELD WIPER/WASHER & VACUUM TUBING

Windshield washer tubing is specially compounded not to deteriorate or split from heat and ozone under the hood. Excellent oil and grease resistance. Applications include windshield washers, power antennas, defrosters, headlight vacuum systems, power seats, power windows, etc. Manufactured to meet S.A.E. J200 BA710.



Qual #	Size	Amt
2090	1/4	10 ft
2091	5/16	10 ft
2092	3/8	10 ft

Above Includes 8 Clamps

### SUPER-ALL FUEL INJECTION HOSE

Exceeds current OEM & SAE specs. Best fuel hose on the replacement market. Min. .030" thickness. Fluorel (3M trademark) lined hose is impervious to emission and fuel penetration. Herclor Epichlorohydrin (ECO) (Hercules trademark) outer tube and cover resists oil, grease, gasoline, heat, ozone and coolants for long lasting performance. Excellent compression set. Burst strength exceeds 900 PSI. Resists temperatures from -30 thru +302°F. Can be used on all known fuel systems.



Qual #	Size	Amt
2101	1 1/32	25 ft
2102	1 5/32	25 ft
3549	Hose Ass't. with Rack	

### CRANKCASE VENTILATION/EMISSION CONTROL HOSE

Anti-smog hose features Hypalon cover & Nitrile tube for maximum oil resistance and extended service life. Handles temperatures as great as 257°F. Meets OEM requirements. Minimum burst 175 PSI.



## SUREFLEX RADIATOR & HEATER HOSE

### Hose Sizes

Qual #	I.D. Size	Qual #	I.D. Size
56280	1/2	56294	2"
56281	5/8	56295	2-1/8
56282	3/4	56296	2-1/4
56283	7/8	56297	2-3/8
56284	1"	56298	2-1/2
56285	1-1/8	56299	2-5/8
56286	1-1/4	56300	2-3/4
56287	1-5/16	56301	2-7/8
56288	1-3/8	56302	3"
56289	1-1/2	56303	3-1/8
56290	1-9/16	56304	3-1/4
56291	1-5/8	56305	3-1/2
56292	1-3/4	56306	4"
56293	1-7/8		



Sureflex Water Hose  
Heavy Duty Wire Reinforced. One wire wrap every 1/4" of length. Buylte Core - smoother than neoprene. Nylon outside reinforcement. For use where quality is a necessity.

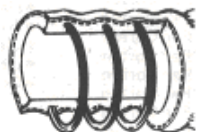

### Adaptors

Qual #	Fits Hose
56310	1-1/2 to 1-1/4
56311	1-3/4 to 1-5/8
56312	1-3/4 to 1-1/2
56313	2" to 1-3/4
56314	2-1/4 to 2"
56315	2-1/2 to 2"
56316	2-3/8 to 2"
56317	2-1/2 to 2-1/4
56318	3" to 2-1/2

### SILICONE HEATER HOSE

Qual#	Size	Pkg
2077	5/8	25
2077-50	5/8	50
2078	3/4	25
2079	1	25
2089	1-1/4	25

## Copper Tubing

### SOFT ANNEALED SEAMLESS

25 FT. per Coil – Boxed

Easy Shaping & bending. For Automotive and general use. Manufactured in America. De-oxidized, bright annealed, and open ends only.

Qual #	O.D. Inch	Wall Thickness	P.S.I.
2140	1/8	.030	1440#
2141	3/16	.030	9574#
2142	1/4	.030	7200#
2143	5/16	.032	5769#
2144	3/8	.032	4800#
2145	1/2	.032	3840#
2146	5/8	.035	3360#
2147	3/4	.035	2800#



### HEAVY DUTY ANNEALED SEAMLESS

50 FT. per Coil- Boxed

Air Brake, Fuel Lines, Hydraulic Lines

Qual #	O.D. Inch	Wall Thickness	P.S.I.
2148	1/4	.035	8400#
2149	5/16	.042	7692#
2150	3/8	.049	7200#
2151	1/2	.049	5400#
2152	5/8	.049	4320#
2153	3/4	.049	3600#



## Steel Brake Line And Tubing

Supplied in Protective Crushproof Tube

LTH inch	3/16 DIA.	1/4 DIA.	5/16 DIA.	3/8 DIA.
DOMESTIC				
8	24991	25001	25011	25021
12	24992	25002	25012	25022
20	24993	25003	25013	25023
30	24994	25004	25014	25024
40	24995	25005	25015	25025
51	24996	25006	25016	25026
60	24997	25007	25017	25027

Bubble Flare German & French	Bubble Flare English & Fiats	Stand. Flare Japanese
------------------------------------	---------------------------------	-----------------------------

METRIC		
25031	25041	25051
25032	25042	25052
25033	25043	25053
25034	25044	25054
25035	25045	25055
25036	25046	25056
25037	25047	25057

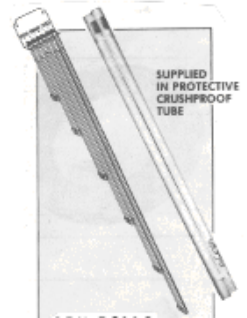

## STEEL TUBING

Qual # Size

2155	3/16 x 25 ft.
2156	1/4 x 25 ft.
2157	5/16 x 25 ft.
2158	3/8 x 25 ft.



## COMPLETE ASSORTMENT 7 SIZES 4 EACH LGTH

Qual #	Size	Fit
24990	3/16	
25000	1/4	
25010	5/16	
25020	3/8	
25030	Metric	BLUE - Fits German-French
25040	Metric	RED - Fits English-Fiats
25050	Metric	PURPLE - Fits Japanese

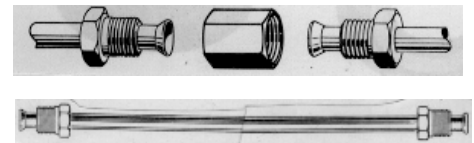

## FLARING TOOL

Qual #: 20123

Has quick opening bars and screw yoke. Heavy duty wing nuts permit quick opening of the 9/16" STEEL BARS. Screw yoke with plated free-wheeling cone permits quicker and smoother flaring. Takes tubing sizes 3/16, 1/4, 5/16, 3/8, 1/2, 5/8.



## DOUBLE FLARING TOOL ADAPTERS

Qual #: 20128

Packed 1 complete set to a box. Each set consists of the following: 1 each of 3/16, 1/4, 5/16, 3/8, 1/2. Double Flare Adapters. To be used with T-21 flaring tool. For steel, copper, aluminum and brass tubing.



## COPPER TUBE CUTTER

Qual #: 20124

A genuine precision cast tubing cutter. Nichrome alloy cutter wheel, two friction-eliminating flare-groove rollers. Slice-lock tool steel reamer. Capacity from 1/8 to 1-1/8".



## HEAVY DUTY TUBE BENDER

Qual #: 20127

Heavy duty tube bender will bend tubing to 360 degrees without kinking. Bends tubing 1/8 to 1/2" diameter.



**TRUCK EXHAUST HOSE CLAMPS**

- **Ease of installation** minimizes problems, errors and costs. No further sealants or welds are necessary.
- **Lightweight.** All sizes weigh between 12 and 16 ounces
- **Rust resistant.** Designed for life of vehicle in aluminized or stainless steel with plated hardware.
- **Unique 360 degree seal** reduces joint failure and closes gaps which emit gases and noise.
- **Open, slip-on design** allows single-handed installation without separating pipes or exhaust members.
- **Reusable** -Pre-formed for accurate I.D. – O.D. installation. Causes no damaging distortion to pipe or flex hose.



Qual #	Size
17054	2"
17055	2-1/2"
17056	2-3/4"
17057	3"
17058	3-1/2"
17060	4"
17061	5"
17062	6"
17063	2-1/4"

**MUFFLER CLAMP BRACKETS**

Qual #: 25099  
360 degree Heavy Duty Universal Hangers. Fits any and all configurations. Perfect for Light Trucks, Vans, Campers, Jeeps, School Buses, Construction & Farm Equipment.

\*Use any muffler clamp to assemble

**PERFECT FOR AUTOMOTIVE, TRUCK AND BUS APPLICATIONS**

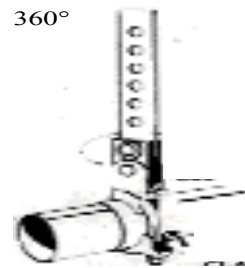
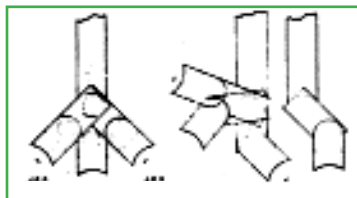

USE ANY CLAMP TO ASSEMBLE

This unique hanger swings Left and right from zero to 45 degrees right & left deep knee bends, and will turn 360 degree at the same time!

**CHANNEL TYPE SADDLE**

Qual #	Size
25070	1- 5/8"
25071	1-3/4"
25072	1-7/8"
25073	2"
25074	2-1/8"
25075	2-1/2"



**OEM TYPE 3/8 U BOLT**

Qual #	Size
25079	1-7/8"
25080	2"
25081	2-1/4"
25082	2-1/2"



**H-D TRUCK TYPE WELDED SADDLE**

Qual #	Size
25089	2-3/4"
25090	3"
25091	3-1/4"
25092	3-1/2"
25093	4"
25094	5"
25095	5-1/2"



**RUBBER UNIVERSAL TIE-DOWN STRAP**



Qual #: 3556  
Metal buckles at each end allow for some adjustment.



Qual #	Length	Span range
2120	10"	15"-20"
2121	15"	20"-30"
2122	21"	30"-40"
2123	31"	40"-50"



Qual #: 3559  
Hooks for 3556 available. 20 per pkg



**ULTRA-MATE BRAND**



**VELCRO HOOK**

Qual #: M-90  
1" Black in 25 yard roll

**VELCRO LOOP**

Qual #: M-91  
1" Black in 25 yard roll

See also pg 106 - 3M Product - Qual #: MMM-06480

# ATC/ATO Fuses and Fuse Holders

## ATC

Qual #	Amp
21463	40
20888	30
21458	25
21459	20
20891	15
21460	10
21461	7 1/2
21462	5
20890	4
20254	3
20255	1

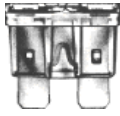

## ASSORTED

Qual #: 21457 contains

Qty	Amp
5	3
5	4
5	5
5	7 1/2
10	10
10	15
30	20
15	25
15	30



Qual #: 20006  
Bx 10  
14 Gauge Leads handle all outputs up to and including 20 Amps

## H.D. FUSE HOLDER

Qual #: 20007  
Bx 10  
Handles all ATC fuses to 30 AMP. High Temp plastic body. Yellow 12 GA. Wire leads.

## ENVIRONMENTALLY SEALED BLADE TYPE ATC/ATO

Qual #: 20009  
Fuse Holder. 3 to 30 Amp Capacity. Electrical system protection for fleets, construction equipment, air-craft service vehicles, outdoor power equipment and marine installations. Bx/ EA



## MINI ATM FUSE HOLDER WITH WATERPROOF CAP

Qual #: 20009-MC  
Bx / 10



## FUSE BLADE TYPE FUSE TAP

Qual #: M-611 Bx 25



Easy alternative to direct wiring for tapping the "hot side" of fuse block. Slide tap onto "hot side" blade of fuse. Insert fuse into fuse block. Connect quick-connect terminal onto protruding tab of tap.

## MINI FUSE BLADE TYPE FUSE TAP

Qual #: M-611-M Bx 50

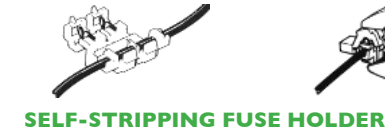

## SELF-STRIPPING FUSE HOLDER

Qual #: 20353 Bx / 10, Qual #: 20353-J Bx / 100

Wire Range 18-14 AWG

- Simplifies hookup and saves money by eliminating need for butt connectors or quick-connect terminals.
- Quicker to install than competitive systems, only two crimps are required.
- Patented self-stripping design requires no wire stripping, speeding installation and reducing possible conductor damage.
- New concept for in-line fusing lets you locate the fuse where you want it.
- Installs with a common pliers so no special tools are necessary.
- Mates w/ most plug-on, blade type fuses in late-model domestic & some import.

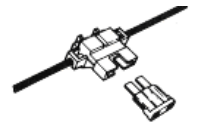
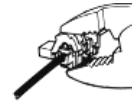

## FUSE HOLDER DISPLAY CARD ASSORTMENT WITH FUSES

Qual #: M-3240

BUSS Fuse holders provide easier way to protect radio, heater, spotlights, other accessories & electronic equipment.

6 Holders with SFE 14, 4 Holders with SFE 20, 2 Holders with SFE 9

12 assorted in-the-line Fuse holders complete with 3 most popular fuses on colorful Display Card. Holders have 8" wire loop staked & soldered to holder terminals. Cut wire for leads of desired length when installing. Holder is black bakelite with bayonet type knob.

## MAXI FUSE HOLDER W/ CAP

Qual #: 20009-MAX

20 to 60 Amp Capacity. With red 8 gauge wire.

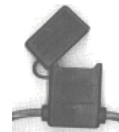

## AUTOMOTIVE ATC CIRCUIT BREAKER

Qual #	Amp
20300	10 amp
20301	15 amp
20302	20 amp
20303	25 amp
20304	30 amp



## MINI FUSES Bx 25

Qual #	Industry No.
20354	ATM - 2 AMP
20355	ATM - 3 AMP
20356	ATM - 4 AMP
20357	ATM - 5 AMP
20358	ATM - 7 1/2 AMP
20359	ATM - 10 AMP
20360	ATM - 15 AMP
20361	ATM - 20 AMP
20362	ATM - 25 AMP
20363	ATM - 30 AMP

## SMALL MINI FUSES Bx 10

Qual #	Industry No.
20346	ATLM- 5 AMP
20347	ATLM- 7.5 AMP
20348	ATLM- 10 AMP
20349	ATLM- 15 AMP
20350	ATLM- 20 AMP
20351	ATLM- 25 AMP
20352	ATLM- 30 AMP

## MAXI FUSES Bx 5

Qual #	Industry No.
20520	MAX 20 AMP
20521	MAX 30 AMP
20522	MAX 40 AMP
20523	MAX 50 AMP
20519	MAX 60 AMP
20519-70	MAX 70 AMP
20519-80	MAX 80 AMP
M-3245	10 pcs Assortment

## PAL AUTO LINK FUSE

Qual #	Amp Rating	Color	Style	See
22960	30	Pink	Female	A
22961	40	Green	Female	A
22962	60	Yellow	Female	A
22963	30	Pink	Male	B
22964	60	Yellow	Male	B
22965	80	Black	Male	B
22966	30	Pink	Bent	C
22967	40	Green	Bent	C
22968	70	Brown	Bent	C

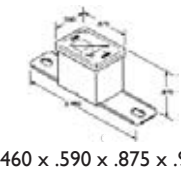
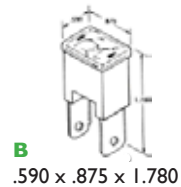
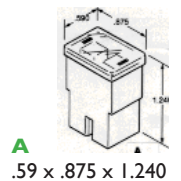

## ASSORTMENT OF PAL AUTO LINK FUSES

Qual #: 22969 10 Assorted Sizes



**FMX MAXI FUSES**

Developed To meet the growing OEM demand for low-profile components., the female FMX Female Maxi fuse offers high-ampere protection in a compact package. Bx each



Qual #	Industry No.	
20511	FMX	20 AMP
20512	FMX	30 AMP
20513	FMX	40 AMP
20514	FMX	50 AMP
20515	FMX	60 AMP
20516	FMX	70 AMP
20517	FMX	80 AMP

**MINI FUSE BLOCK EXTENSION**

Qual #: M-611-MF

**ATC FUSE BLOCK EXTENSION**

Qual #: M-609-FA

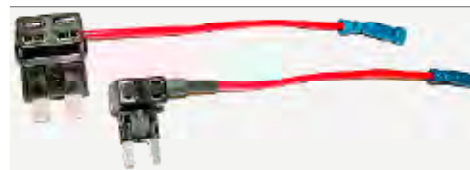

An innovative add-a-circuit, two slot plug that provides wire lead for splicing portable electronic devices (up to 10 amps) into the fuse block. One slot accepts the original vehicle fuse; the other accepts the fuse for a phone, fax, radio, etc. eliminating the need for an additional fuse holder. Bx each

**FEATURES**

1. Turns one fuse into two.
2. Plugs into occupied or vacant slot.
3. Provides one fuse holder to protect existing circuit, and a second fuse holder to protect the new circuit.
4. 10-AMP rating at 12 volts 16-gauge lead for new circuit is 5" long and includes an insulated crimp-type coupler.

**Glass Fuses**

**1/4 X 5/8 Bx 25**



Qual #	Industry No.
22889	AGA - 1 AMP
22890	AGA - 1-1/2 AMP
22891	AGA - 2 AMP
22891-A	AGA- 2-1/2 AMP
22892	AGA - 3 AMP
22893	AGA - 5 AMP
22893-A	AGA- 6 AMP
22894	AGA - 7-1/2 AMP
22895	AGA - 10 AMP
22896	AGA - 15 AMP
22897	AGA - 20 AMP
22897-A	AGA- 25 AMP
22898	AGA - 30 AMP
Z22898-A	AGA-50 AMP

**1/4 X 7/8 Bx 25**



Qual #	Industry No.
22899	AGW - 2-1/2 AMP
22900	AGW - 4 AMP
22901	AGW - 5 AMP
22902	AGW - 6 AMP
22902-B	AGW- 10 AMP
22903	AGW - 15 AMP
22904	AGW - 20 AMP
22905	AGW - 30 AMP

**1/4 X 1 Bx 25**

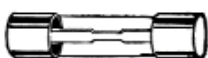

Qual #	Industry No.
22909-B	AGX- 2 AMP
22909-C	AGX-2-1/2
22910	AGX - 20 AMP
22911	AGX - 25 AMP
22912	AGX - 30 AMP

**1/4 X 1-1/4 Bx 25**

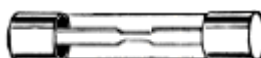

Qual #	Industry No.
22924	AGC - 1 AMP
22925	AGC - 1-1/2 AMP
22926	AGC - 2 AMP
22927	AGC - 2-1/2 AMP
22928	AGC - 3 AMP
22929	AGC - 4 AMP
22930	AGC - 5 AMP
22930-A	AGC- 6 AMP
22931	AGC - 7-1/2 AMP
22932	AGC - 10 AMP
22933	AGC - 15 AMP
22934	AGC - 20 AMP
22935	AGC - 25 AMP
22936	AGC - 30 AMP
22937	AGC - 35 AMP

**9/32 X 1-1/4 Bx 25**



Qual #	Industry No.
22920	AGS - 10 AMP
22921	AGS - 15 AMP
22922	AGS - 20 AMP
22923	AGS - 30 AMP

**1/4 X 31/32 Bx 25**



Qual #	Industry No.
22906	GBC - 5 AMP
22907	GBC - 8 AMP
22908	GBC - 16 AMP
22909	GBC - 25 AMP

**MISC FUSES**

Qual #	Industry No.
22945	GBF- 25 AMP
22912-C	AGY- 50 AMP

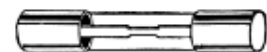

Qual #	Industry No.	Size
22938	SFE- 4 AMP	1/4x5/8
22939	SFE- 6 AMP	1/4x3/4
22940	SFE- 7-1/2	1/4x7/8
22941	SFE- 9 AMP	1/4x1"
22942	SFE-14 AMP	1/4x1-1/16
22943	SFE-20 AMP	1/4x11/14
22944	SFE-30 AMP	1/4x1-7/16



**FUSE PULLER**

Qual #: 22915  
For glass or all ATC fuses.



**GLASS TUBE FUSE HOLDER**

Qual #: 20008  
Weatherproof 30 AMP Rated Universal Glass Tube Fuse Holder. Easy to install by simply crimping the holder onto wire.



# Miniature Bulbs

Bulb #	Qual #	Voltage System	Candle Power	Fig #
1A/27W	I2198	12.8	50	
1A/50W	I2199	12.8	108	
53	I2202	12	1	3
55	I2203	6	2	3
57	I2204	12	2	4
67	I2205	12	4	6
68	I2206	12	4	5
70	I2206-70	14	1.5	
73	I2206-73	12	0.3	
74	I2349	14	.70	
86	I2285	6.3	.40	
89	I2207	12	6	6
90	I2208	12	6	5
93	I2209	12	15	9
94	I2210	12	1.5	9
97	I2211	12	4	6
105	I2212	12	12	1
158	I2213	12	2	11
161	I2213A	12	1	11
168	I2212A	14	3.0	
194	I2214	12	2	11
194A	I2215	12	-	11
198	I2216	12	3/32	8
199	I2217	12	32	9
211-2	I2218	12	12	17
212-2	I2219	12	6	17
272	I2220			
307	I2221	24	21	8
303	I2222	24	6	6
313	I2223	24	3.5	10
330	I2223-330	12	0.5	
334	I2224	24	.34	18
456	I2225	24	2	4
561	I2226	12	12	15
562	I2227	12	6	15
563	I2228	12	4	15
623	I2229	24	6	6
624	I2230	24	6	5
631	I2231	12	6	6
756	I2232	14	.31	10
757	I2233	24	.08	10
906	I2277	13	6.0	
906A	I2284	13		
912	I2233-912	12.8	12.0	
916NA	I2278	13.5	1.5	
1003	I2234	12	15	1
1004	I2235	12	15	2
1034	I2236	12	4/32	8
1073	I2237	12	32	9
1076	I2239	12	32	7
1141	I2240	12	21	9
1155	I2241	12	4	6
1156	I2242	12	32	9
1156A	I2281	Limited Stock Available		
1157	I2243	12	4/32	8
1157A	I2244	12	-	8
1157NA	I2246	12	-	8
1159	I2247	12	6/21	9
1178	I2248	12	4	5
1195	I2250	12	50	13
1196	I2251	12	50	14
1203	I2252	24	21	9
1251	I2253	24	3	6
1252	I2254	24	3	6
1295	I2255	12	50	9
1445	I2256	12	.7	3
1450	I2257	24	.23	3
1638	I2259	24	32	8
1662	I2260	24	32	7

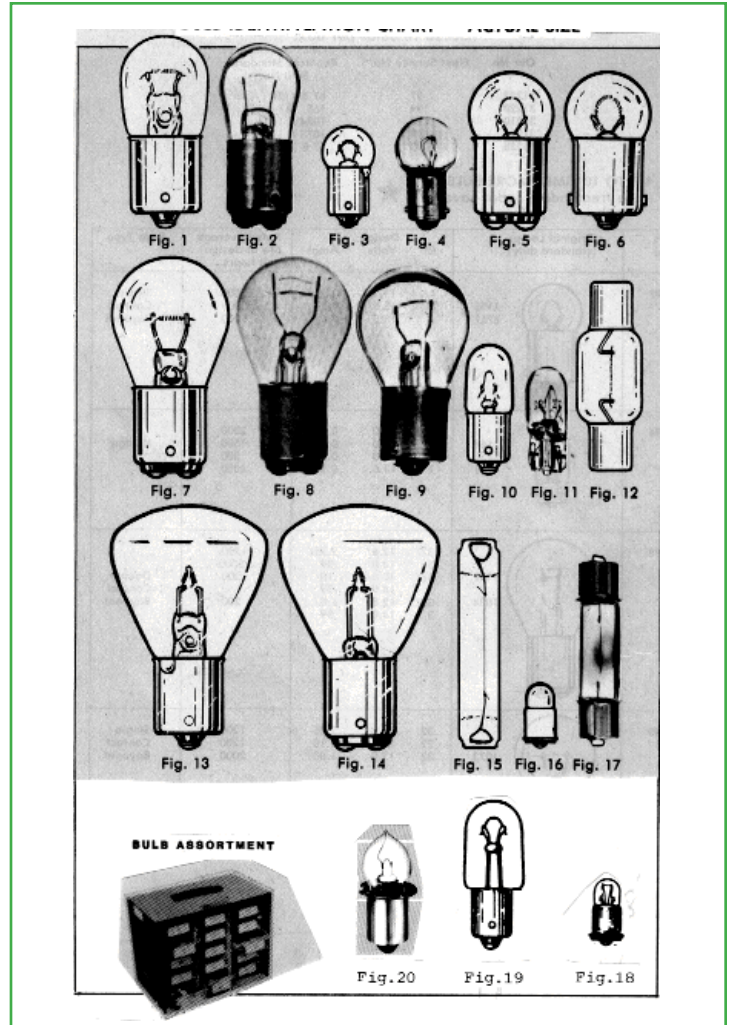

## MINIATURE BULB ASSORTMENT

Qual #: I2330

Ten each of 17 Popular Sizes in a 15 Drawer Cabinet, Contains numbers; 53, 57, 67, 89, 97, 194, 211-2, 212-2, I003, I004, I034, I073, BI156, I157, I157NA, I816 & I895. Pkg. I0 except for Halogen which are pkg I

Bulb #	Qual #	Voltage System	Candle Power	Fig #
1665	I2261	24	21	9
1683	I2262	24	32	9
1691	I2263	24	15	9
1815	I2264	12	1.4	10
1816	I2265	12	3	10
1819	I2266	24	.34	10
1891	I2268	12	2	10
1893	I2269	12	2	10
1895	I2270	12	2	4
2057	I2271	12.8	32	
2057NA	I2272	12.8	24	
3057	I2275	12.8		
3057NA	I2276	12.8	24	
3156	I2282	12.8	32	
3156NA	I2283			
3157	I2279			
3157NA	I2280	12.8	24	
PR-2	I2200	2.38	.50A	20
PR-13	I2201	4.75	.50A	20
HI-55W	I2332	12	Halogen	
H3-55W	I2335	12	Halogen	

## Sealed Beam Lamps

Mfg. No.	Qual#	Volts	Watts	Bulb	Base
4000	I2300	12	37.5	3 Lug	PAR 46
4001 USE 5001	I2301	12	37.5	2 Lug	PAR 46
4411	I2302	12	35	SCR..Term	PAR 36
4412	I2303	12	35	SCR..Term	PAR 46
4412A	I2304	12	35	SCR..Term	PAR 46
4413	I2305	12	35	SCR..Term	PAR46
4416	I2306	12	30	SCR..Term	PAR 36
4416R	I2306R				
4419	I2307	12	35	SCR..Term	PAR 46
4421	I2308	12	100	Slip-on Term	PAR 46
4435	I2309	12	30	SCR..Term	PAR 46
4436	I2310	12	35	SCR..Term	PAR46
4436R	I2311	12	35	SCR..Term	PAR 46
4531	I2312	12	40	SCR..Term	PAR 46
4578	I2313	24	60	2 Lug	PAR 46
4579	I2314	24	80	3 Lug	PAR 46
4636	I2315	12	75	SCR..Term	PAR 46
4651	I2316	12	50	2 Lug	RECT.
4652	I2317	12	60-40	3 Lug	RECT.
4880	I2318	24	60	2 Lug	PAR 46
5001	I2319	12	50	2 Lug	PAR 46
6014	I2320	12	60-50	3 Lug	PAR 56
6015	I2321	12	60-50	3 Lug	PAR 56
6052	I2322	12	65	3 Lug	RECT.
7400	I2323	12	35	SCR..Term	PAR 36

Case quantity 12 or Ea (-1)

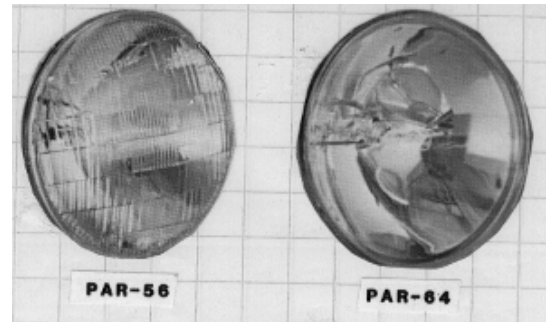
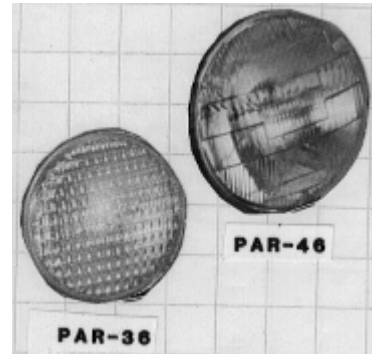

Mfg. No.	Qual#	Volts	Watts	Bulb	Base
H-6024BL Xenon	I2337				
H-7600	I2338				
H-4651	I2339	12	Halogen	2 Lug	RECT.
H-4656	I2340	12	Halogen	3 Lug	RECT.
H-5001	I2341	12	Halogen	2 Lug	PAR 46
H-5006	I2342	12	Halogen	3 Lug	PAR 46
H-6024	I2343	12	Halogen	3 Lug	PAR 56
H-6054	*I2344	12	Halogen	3 Lug	RECT.
H-9004	*I2345	12	Halogen	3 Prong	
H-9005	*I2346	12	Halogen	2 Prong	
H-9006	*I2347	12	Halogen	2 Prong	
H-9007	*I2347A				
H-7635	*I2348-1	12	Halogen		

Case quantity 12 or Ea (-1) except \* which are only sold as each

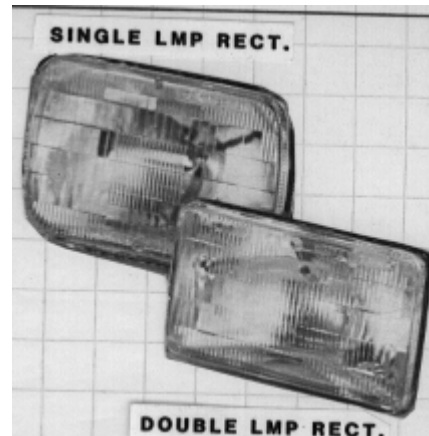

# Lamps

## FLUORESCENT

Qual #: 12365  
15/cs (-1)ea  
75w, 8ft., Cool White

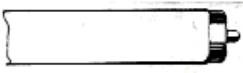

Qual #: 12366  
30/cs (-1)ea  
40w, 4 ft., Cool White

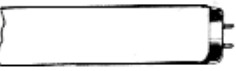

Guaranteed for 20,000 Hours

## FLUORESCENT DROP LIGHT

Qual #: 12371  
2 prong 13w



## OUTDOOR LIGHTING LAMPS

Heavy Duty 2,000 Hour Service  
Special Heat-resistant glass bulb  
Pkg 12 (-1) ea Fl= flood SP=spot



Qual#	Mfg.	Size
12358	75 PAR/FL	75W
12359	75 PAR/SP	75W
12360	150 PAR/FL	150W
12361	150 PAR/SP	150W

## QUALITY ROUGH SERVICE LAMPS

TUFF SKIN  
Now Designed with THORIATED Filament Exclusively for the Automotive Industry. Won't shatter weather-proof higher voltage filament for longer life.

Qual #	Volts	Watts	Pkg.
12362	12V	25W	12
12363	12V	25W	120
12369	12V	50W	12
12370	12V	50W	120
12350	110V	50W	12
12351	110V	50W	120
12352	110V	75W	12
12353	110V	75W	120
12354	110V	100W	12
12355	110V	100W	120
12356	110V	100W	12
12357	110V	100W	120



# Flashers

## VARIABLE LOAD - TUNG-SOL

Variable load flashers can flash a greater number of lamps, and as such, have been designated heavy duty. This heavy duty designation does not imply any greater product life compared to standard O.E. equipped fixed load flashers.

Qual #	Mfg. No.	Prong	Volts	Description	Type	Pkg.
12390	550	3	12	Round H.D. Long	B	5
12391	552	2	12	Round H.D. Short	A	5
12392	536	2	12	Round H.D. Long	C	5
12393	537	3	12	Round Alternating	A	5

### TYPE A



### TYPE B & C



## EXTRA HEAVY DUTY - SIGNAL STAT

Ever-Flash heavy duty flashers.- Plastic housing and bracket - 12 Volt

Qual #	Mfg. No.	Prong	Volts	Description	Type	Pkg.
12394	850/5X	3	12	Flashers 1-8 Bulbs	D	1
12395	852/5X	2	12	Flashers 1-8 Bulbs	D	1

### TYPE D

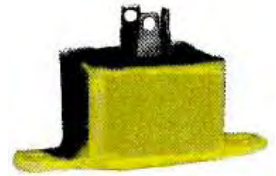

## VARIABLE LOAD - SIGNAL STAT

Qual #	Mfg. No.	Prong	Volts	Description	Type	Pkg.
12396	121	3	24	Rectangular	E	1
12397	175	2	12	Rectangular	E	5
12398	180	3	12	Rectangular	E	5

### TYPE E



## EXTRA HEAVY DUTY - SIGNAL STAT

Transistorized Flashers - Extra heavy duty truck flashers. Eliminates flasher burnout. Flashes 2 to 4 bulbs for turn signal; or 2 to 8 bulbs for hazard warning signal.

Qual #	Mfg. No.	Prong	Volts	Description	Type	Pkg.
12401	250	2	12	Trans Neg. Ground	F	1
12402	252	3	12	Trans Neg. Ground	F	1
12403	256	3	12	Trans Alt.Neg.Grnd	F	1
12404	258	2	24	Trans Neg. Ground	F	1

### TYPE F

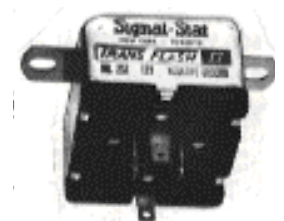

## Blind Pull Rivets

USE #41 DRILL - 3/32

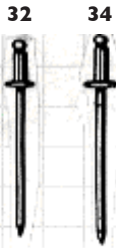

USE #30 DRILL - 1/8

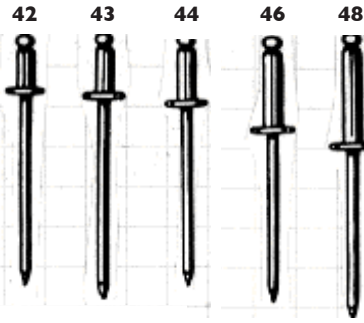

USE #20 DRILL - 5/32

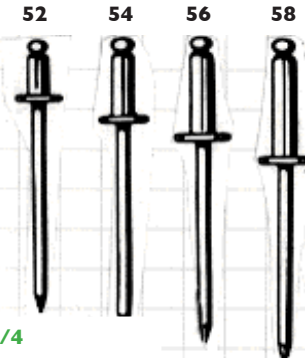

USE #11 DRILL - 3/16

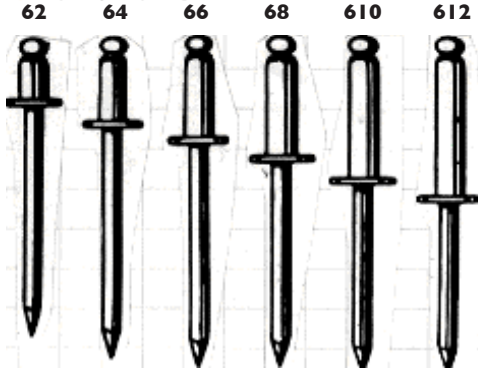

USE 1/4 DRILL - 1/4

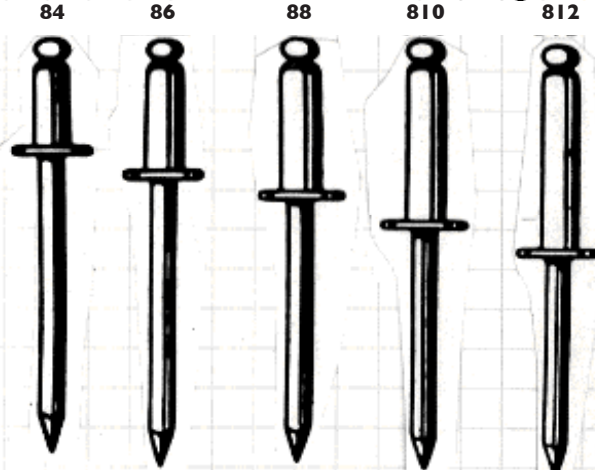

Illustration Number	Diameter	Work Thickness	Alum. Rivet AlumMand.	Alum. Rivet Steel Mand.	Steel Rivet Steel Mand.	Stainless Rivet StainlessMand.
32	3/32	1/32-1/8	10140	10162	10184	
34	3/32	1/8-1/4	10141	10163	10185	
42	1/8	1/16-1/8	10142 *	10164	10186 * +	10206
43	1/8	1/8-3/16	10143	10165	10187 * +	
44	1/8	3/16-1/4	10144 *	10166	10188 * +	10207
46	1/8	1/4-3/8	10145	10167	10189 *	10208
48	1/8	3/8-1/2	10146	10168	10190	
52	5/32	1/32-1/8	10147		10191	
54	5/32	1/8-1/4	10148		10192	
56	5/32	1/4-3/8	10149		10193	
58	5/32	3/8-1/2	10150		10194	
62	3/16	1/32-1/16	10151		10195	10209
64	3/16	1/8-1/4	10152	10174	10196 *	10210
66	3/16	1/4-3/8	10153 *	10175	10197 *	10211
68	3/16	3/8-1/2	10154 *	10176	10198 *	10212
610	3/16	1/2-5/8	10155 *	10177 *	10199 *	
612	3/16	5/8-3/4	10156 *	10178	10200 *	
84	1/4	1/8-1/4		10179	10201	
86	1/4	1/4-3/8		10180	10202	
88	1/4	3/8-1/2		10181	10203	
810	1/4	1/2-5/8			10204	
812	1/4	5/8-3/4			10205	

\* These sizes avail. also w/  
Large Flange Head  
**Add - LF to #**

+ These sizes avail. also as  
Countersunk Type  
**Add - C to #**

# Rivets

## THE MULTI-RANGE RIVET

Fast, simple, certain, and provides maximum clamping action over a wide range of material thicknesses... from a single rivet! Installed with conventional rivet tool!

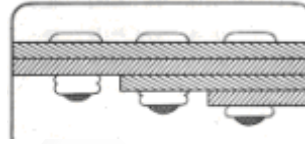

## LARGE FLANGE RIVET

Aluminum Rivet with Steel Mandrel



Qual #	Dia.(A)	Lgth.(B)	Grip	Pkg.
37354-LF	3/16	17/32	To-1/4	100
37355-LF	3/16	17/32	To-1/4	500
37356-LF	3/16	17/32	To-1/4	1000
37357-LF	3/16	3/4	To-7/16	100
37358-LF	3/16	3/4	To-7/16	500
37359-LF	3/16	3/4	To-7/16	1000

## BACK UP WASHERS

Qual #	Rivet Size	Qty.
10230	1/8	100
10231	5/32	100
10232	3/16	100
10233	1/4	100



## DOME HEAD RIVET

Aluminum Rivet with Steel Mandrel

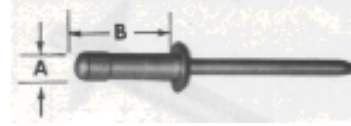

Qual #	Dia.(A)	Lgth.(B)	Grip	Pkg.
37348	1/8	3/8	To-1/4	100
37349	1/8	3/8	To-1/4	500
37350	1/8	3/8	To-1/4	1000
37351	5/32	1/2	To-1/4	100
37352	5/32	1/2	To-1/4	500
37353	5/32	1/2	To-1/4	1000
37354	3/16	17/32	To-1/4	100
37355	3/16	17/32	To-1/4	500
37356	3/16	17/32	To-1/4	1000
37357	3/16	3/4	To-7/16	100
37358	3/16	3/4	To-7/16	500
37359	3/16	3/4	To-7/16	1000

# Special Rivets

## TRIM MOLDING CLIP RIVETS

These 1/8" diameter, stainless steel shoulder rivets are specifically designed to quickly and easily attach trim molding clips to auto body exteriors. The rivet shoulder is formed by using a special "stand-off" nosepiece.

Qual #: 10240

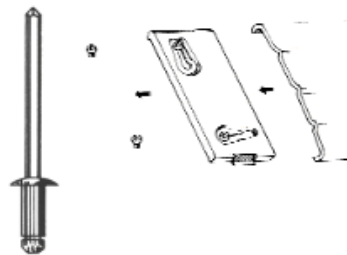

## STAND OFF NOSEPIECE

Qual #: 10241  
(For 10220 Riveter)

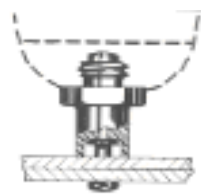

## SPLIT RIVETS

These patented 1/4" blind rivets are used by most American automobile manufacturers to attach the window regulator mechanism to the door or body panel; to attach the nylon glass stops to both the glass and regulator and to attach the latch to the door panel. Use a heavy duty riveter such as Qual #: 10223 with special nosepiece Qual #: 10224 for proper installation.

## WINDOW REGULATOR RIVET

Qual #: 10243

Door or Body Panel Regulator

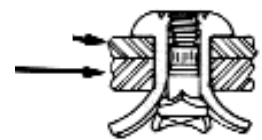

## GLASS STOP RIVET

Qual #: 10244 (Ford & Chrysler) 1/4 Steel  
Qual #: 10248A (GM, Ford & Chrysler) 1/4 Aluminum



Glass Stop (2pc) Glass

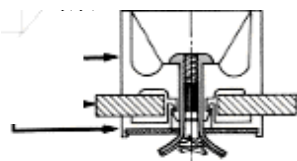

## DOOR HANDLE RIVET

Qual #: 10249 (Ford & Chrysler)

Latch Door Panel





## Special Rivets

### BLIND RIVET

Qual #: 10247

Used in repair of Pinto & Bobcat front & rear bumpers. (Ford Part #388442-S100) **Use Riveter Qual #: 10223**



**NOTE:** To meet Federal Motor Vehicle Safety Standards and to prevent galvanic corrosion, only rivets Part. No. 388442-S100 can be used. No substitutions are permitted.

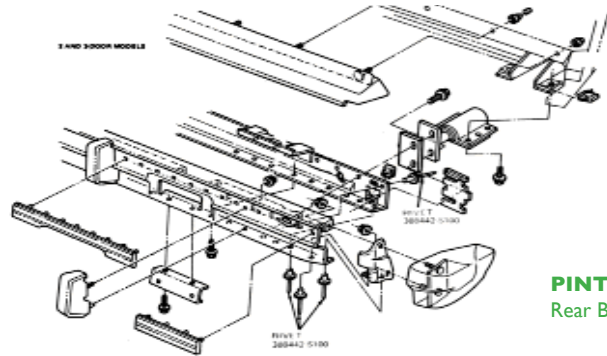

**PINTO & BOBCAT**  
Rear Bumpers

### UNIVERSAL DRIVE RIVETS ALUMINUM WITH SS PIN

Qual #: 8598-8600

### ALUMINUM DRIVE RIVETS WITH SS PINS

Qual #: 8580-8597

### BRAZIER HEAD SOLID ALUMINUM RIVETS

Qual #: 8625-8631

All available special order

### PLASTIC DRIVE RIVET

Qual #: 38706

Qual #: 387944-S (Nylon)

Grille to Metal Stamping

FORD: Econoline '78-'82

### DRIVE RIVET

Qual #: 38705

Qual #: 387843-S (Nylon)

Black Nylon Drive Rivets

FORD PRODUCT ALL '78-'81.

Fastens Inner Fender to Car Body

### PEEL - TYPE RIVET

Qual #: 46458 Bx 10

1/4" Diameter, Grip 1/8"-21/64, Flange Dia. 3/4", Aluminum Rivet (black) Aluminum Mandrel Door Lock Actuator Ford Continental, Crown Victoria, F series Truck, Sable Grand Marquis, Marx VII, Taurus, Mustang, Ranger, Town Car & Windstar 1995-ON



### SPLIT-TYPE RIVET

Qual #: 44639 Bx 15

1/4" Diameter, Grip 3/16"-3/8, Flange Dia. 11/16", Aluminum Rivet (black) Aluminum Mandrel Attachment of Bumper Cover to Bumper & front License Plate Bracket to Bumper Cover Ford 1992-ON, Air Dam to Fascia Chrysler 1993-ON



## RIVET GUNS

### SUPER HEAVY DUTY HAND RIVETER

Qual #: 10220

Has extra long handles for setting most rivets in one easy stroke. Extra nosepieces included.

Material		Rivet Diameters				
Rivet	Mandrel	3/32	1/8	5/32	3/16	1/4
Alum.	Alum.	•	•	•	•	
Alum.	Steel	•	•	•	•	
Steel	Steel	•	•	•	•	
Stainless	Stainless	•	•	•	•	



### TWO HANDED HEAVY DUTY TOOL

Qual #: 10223

Can be used on 3/16 & 1/4 rivets, including split rivets. Extra nosepiece included Nose piece for 1/4 split rivets not included.

**Nose piece Qual #: 10224**

Material		Rivet Diameters	
Rivet	Mandrel	3/16	1/4
Alum.	Alum.	•	•
Alum.	Steel	•	•
Steel	Steel	•	•
Stainless	Stainless	•	•

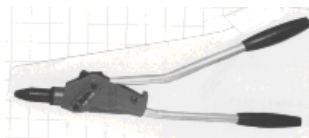

### RIVET GUN & ASSORTMENT OF RIVETS

Qual #: 10219

Sturdy plastic storage case holds Marson riveter gun, 5 boxes of rivets, and a nosepiece wrench. For daily use on riveting metal, wood, masonry, and Formica. Rubber composition grips.



## Hair Pin Retainers

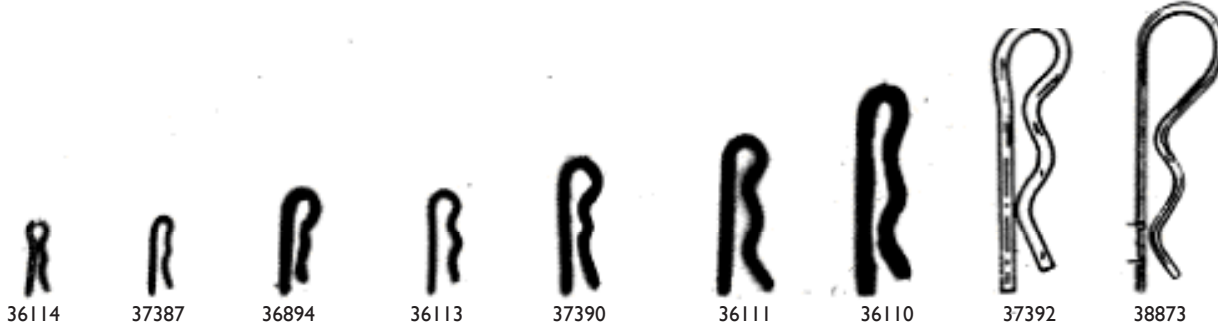
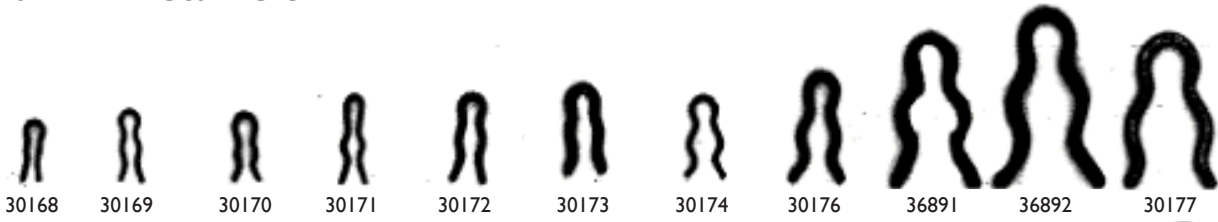

### ASSORTMENT

Qual #: 1802

Includes all the numbers from the second row along with Qual #: 37391 & Qual #: 38872 in a Qual #: 10047 plastic box with label.

Qual #: 1807 includes all the numbers from the top row packed in a Qual #: 10047 plastic box with label.

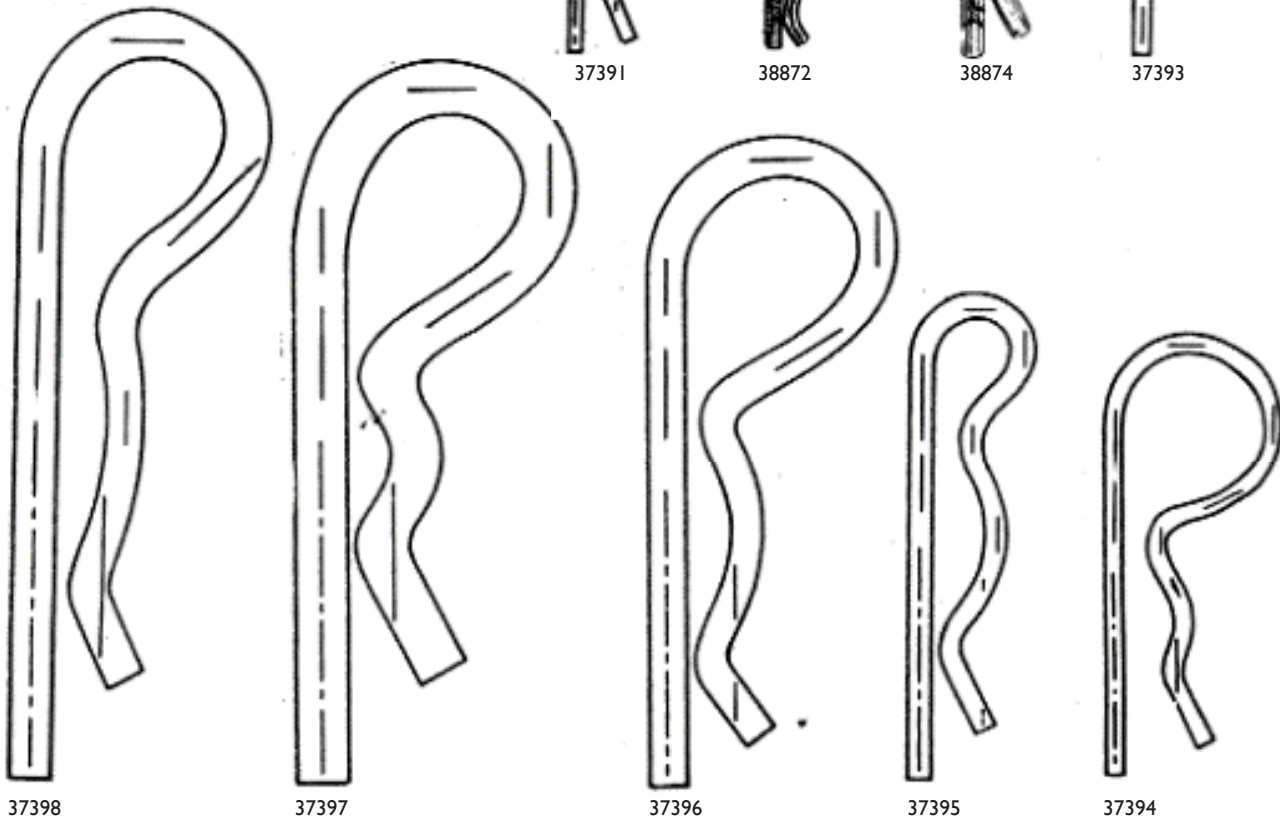
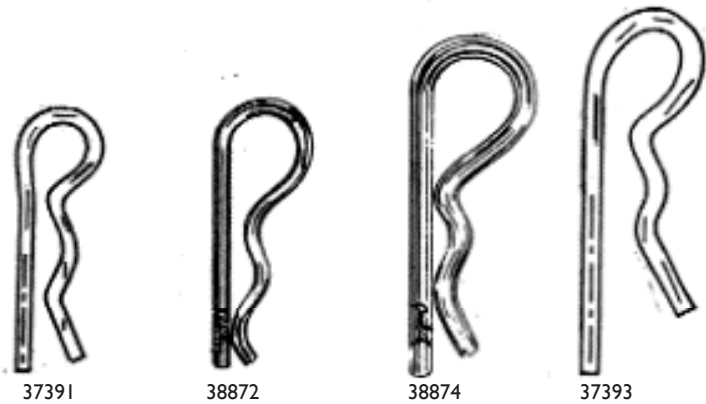

### KEY STOCK

Pkg 1 EA



Qual #	Size
36794	3/16" x 3/16" x 12"
36795	1/4" x 1/4" x 12"
36796	5/16" x 5/16" x 12"
36800	3/8" x 3/8" x 12"
36801	7/16" x 7/16" x 12"
36802	1/2" x 1/2" x 12"
36797	9/16" x 9/16" x 12"
36798	5/8" x 5/8" x 12"
36799	3/4" x 3/4" x 12"

### KEY STOCK ASSORTMENT

Qual #: 45530

Contains sizes 3/16 - 3/4 in  
#10038 Cabinet



### WOODRUFF KEYS Pkg 25

Qual #	Width	Diameter	Stand #
30877	1/8	1/2	3
30878	1/8	5/8	5
30879	1/8	3/4	7
30879A	3/32	1/2	2
30880	3/32	5/8	4
30881	5/32	5/8	6
30882	5/32	3/4	8
30883	5/32	7/8	10
30884	3/16	3/4	9
30885	3/16	7/8	11
30886	3/16	1	13
30887	3/16	1-1/8	16
30888	7/32	7/8	12
30889	7/32	1	14
30890	7/32	1-1/8	17
30891	1/4	7/8	A
30892	1/4	1	15
30893	1/4	1-1/8	18
30894	1/4	1-1/4	21
30895	5/16	1	B
30896	5/16	1-1/8	C

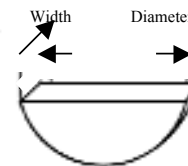

### ASSORTMENTS

Qual #: 1803 Contains the six most popular Woodruff Keys used for automotive repair.

Qual #: 1804 Contains the second series of six most commonly used keys in automotive repair.

Qual #: 1805 Contains 20 sizes of most popular numbers.

### CARBURETOR CLIPS

Qual #	Size
30785	3/32 LH
30784	3/32 RH
30610	5/32 LH
30609	5/32RH
30612	3/16 LH
30611	3/16 RH
30614	1/4 LH
30613	1/4 RH



### LINKAGE CLIP ASSORTMENTS

Qual #: A-1255

Contains 8 sizes in Labeled Plastic Tray

### CARBURETOR SMALL PARTS ASSORTMENTS

Qual #: A-1330

Clips, Wing Nuts, "E" Rings in Metal Tray

### RUBBER MANIFOLD CAPS

Qual #	Size	OEM #	Pkg
39209	1/8"	380615-S 387466-S	25
31440	3/16"	380614-S	25
31439	1/4"	380613-S 54794	25
39907	5/16"	389129-S	25
39210	3/8"	385353-S 14008227	25
39908	1/2"	388916-S	10



### SLOTTED FILLISTER HEAD SPRING CENTER BOLTS AND NUTS

Plain Black Finish



Qual #	Size	Pkg	Qual #	Size	Pkg
32422	5/16-24X3-1/2"	25	32429	7/16-20X6"	10
32423	5/16-24X5"	25	32430	7/16-20X8"	10
35950	5/16-24X12"	10	32431	7/16-20X10"	10
32424	3/8-24X5"	10	32803	7/16-20X12"	10
32425	3/8-24X6"	10	32432	1/2-20X6"	10
32426	3/8-24X8"	10	36323	1/2-20X8"	10
32427	3/8-24X10"	10	32433	1/2-20X10"	10
32802	3/8-24X12"	10	32804	1/2-20X12"	10
32428	7/16-20X5"	10			

### MANIFOLD CAPS ASSORTMENT

Qual #: 1806

6 sizes in labeled Plastic Tray



### LYNCH PINS

Qual#	Pin Size	Ring I.D.	Ring O.D.	Pkg
38733	7/16 O.D. x 2-1/4" long w/rings	1-3/4"	1-15/16"	5
38736	1/4 O.D. x 2-1/8" long w/rings	1-5/8"	1-7/8"	10



## Plastic Connectors

### NULON UNIVERSAL BREAK-OFF TEE

Qual #: 37368  
For 1/8", 1/4", and 3/8" tubing



### BUTYRITE BREAK-OFF UNIVERSAL TUBING CONNECTOR

Qual #: 38321  
1/8", 1/4", 3/8"



### HIGH-DENSITY POLYETHYLENE TEE CONNECTORS Pkg 10

Barbed on all Sides

Qual #	Size
37108	5/32"
37109	3/16"
37110	1/4"



### 3/8"

Qual #: 39928  
All ends GM, Ford, AMC  
general purpose.



### POLYETHYLENE TEE CONNECTOR

Qual #: 37697  
1/8" all ends, general  
purpose.



### NYLON TEE CONNECTOR

Qual #: 38738

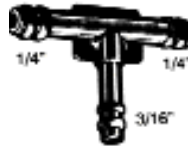

### HIGH-DENSITY POLYETHYLENE HOSE CONNECTORS Pkg 10

Barbed on all Sides

Qual #	Size	Qual #	Size
37101	1/8"	37104	5/16"
37102	3/16"	37105	3/8"
37103	1/4"		



### WASHER AND VACUUM HOSE

Qual #: 38419  
3/16", 4 way GM, Ford



### HIGH-DENSITY POLYETHYLENE REDUCER CONNECTORS Pkg 10

Barbed on all Sides

Qual #	Size
37106	1/4" x 3/16"
37107	3/8" x 1/4"



## Nutserts

Now Two Styles - Nutserts Make A Nut In Thin- To-thick Metal, Plastic, & Fiber Glass

### REGULAR STEEL NUTSERTS

The Regular Nutsert should be used to obtain load-bearing threads in material where application's grip is too large for the Thin Sheet Nutserts. When installed, the threaded section wedges into the sleeve forming a 360° contact to parent material.

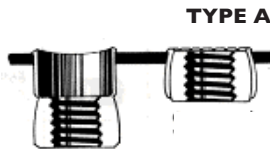

TYPE A	MILD STEEL CADMIUM PLATED				
Qual #	Type	Thread Size	Hole Size	Length	Pkg
37264	A	6-32	7/32	.370	25
37267	A	8-32	1/4	.370	25
37270	A	10-24	9/32	.370	25
37273	A	10-32	9/32	.370	25
37276	A	1/4-20	3/8	.510	25
37279	A	1/4-28	3/8	.510	25
37282	A	5/16-18	1/2	.610	10

Qual #'s 37265-37281 contain same sizes in large boxed quantities.

### THIN STEEL NUTSERTS

The Thin Sheet Nutsert provides an efficient method of securing threads from one side of the work, in materials generally too thin to support them. Use in mild steel, aluminum, plastic and fiberglass.

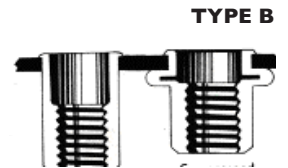

TYPE B	1010 LOW CARBON STEEL ZINC PLATED				
Qual #	Type	Thread Size	Hole Size	Lgth	Pkg
37285	A	5/16-24	1/2	.610	10
37288	A	3/8-16	9/16	.740	10
38310	B	6-32	.250	.410	25
38311	B	8-32	.250	.410	25
38312	B	10-24	.281	.465	25
38313	B	1/4-20	.375	.610	25
38314	B	5/16-18	.500	.720	25

### NUTSERT HAND TOOL

Qual #: 38805  
For regular and thin sheet  
Nutserts. Hand tool with  
wrench. Each

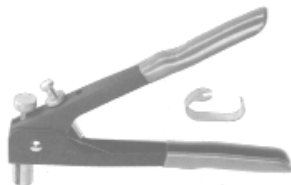

### NUTSERT HAND TOOL

Qual #: 38806  
Complete in metal case. Includes hand  
tool 38805, nose piece wrench,  
and conversion kits (nose piece & mandrel)  
for the following sizes: 6-32, 8-32, 10-24,  
10-32, 1/4-20 & 5/16-18

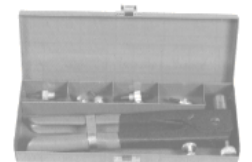

## Grease Connectors



**1/4-28 THREAD**

 Qual #: 56406 Short	 Qual #: 56404 Medium	 Qual #: 56407 Long	 Qual #: 56405 45°	 Qual #: 56408 90°	 Qual #: 56415 Straight
--	--	--	---	---	--



**1/8 PIPE THREAD**

 Qual #: 56400 Short	 Qual #: 56401 45°	 Qual #: 56392 30°	 Qual #: 56403 90°	 Qual #: 56402 67-1/2°	 Qual #: 56411 1-1/4 Long	 Qual #: 56412 1-3/4 Long
--	---	---	---	--	--	--

**THREAD TAPPING - 1/4-28**

 Qual #: 56399 Short	 Qual #: 56391 45°	 Qual #: 56390 90°
--	--	--

**DRIVE TYPE**



 Qual #: 56409 3/16	 Qual #: 56410 5/16
---	--

**ASSORTED FITTINGS**

Qual #: A-1242  
6 sizes assorted grease fittings in plastic tray.

Qual #: A-1243  
13 sizes assorted grease fittings in large metal tray.

**METRIC GREASE FITTINGS**

Qual #	Thread	Length		Qual #	Thread	Angle		Qual #	Thread	Angle	
56393	6mm	7/16		56394	6mm	45°		56395	6mm	90°	
56396	8mm	5/8		56397	8mm	45°		56398	8mm	90°	
56387	10mm	3/4		56388	10mm	45°		56389	10mm	90°	

**METRIC ASSORTMENT** Qual #: A-1233

**SOCKET HEAD SET SCREWS AND WRENCHES**

Qual #	Size
32414	1/16
32415	No. 8
32416	3/16
32417	1/4
32418	5/16
32419	3/8



Qual #	Size	Use Tool #	Qual #	Size	Use Tool #
32365	6-32 x 3/16	32414	USS	SAE	
32366	6-32 x 1/4	32414	32380	32400	1/4 x 5/16
32367	6-32 x 5/16	32414	32381	32401	1/4 x 3/8
32368	6-32 x 3/8	32414	32382	32402	1/4 x 7/16
32369	8-32 x 3/16	32415	32383	32403	1/4 x 1/2
32370	8-32 x 1/4	32415	32384	32404	5/16 x 1/4
32371	8-32 x 5/16	32415	32385	32405	5/16 x 5/16
32372	8-32 x 3/8	32415	32386	32406	5/16 x 3/8
32373	8-32 x 1/2	32415	32387	32407	5/16 x 7/16
32374	32394	10 x 3/16	32388	32408	5/16 x 1/2
32375	32395	10 x 1/4	32389	32409	3/8 x 5/16
32376	32396	10 x 5/16	32390	32410	3/8 x 3/8
32377	32397	10 x 3/8	32391	32411	3/8 x 7/16
32378	32398	10 x 1/2	32392	32412	3/8 x 1/2
32379	32399	1/4x 1/4	32393	32413	3/8 x 5/8



**ASSORTMENT**

Qual #: A-1217  
Available with set screws and wrenches included

# Standard & Oversize Studs

AVAILABLE IN ASSORTMENTS: Qual #A-1219 & A-1220

For Wheels, Manifold and General Purpose (10 Per Pack)

	Qual #	Overall Length	Diam A	Length Thread	Diam B	Length Thread
1/4"	36667	1"	1/4"	SAE-7/16"	1/4"	USS-7/16"
	36668	1-1/4"	1/4"	SAE-1/2"	1/4"	USS-1/2"
	36669	1-1/2"	1/4"	SAE-3/4"	1/4"	USS-1/2"
	36670	2"	1/4"	SAE-1"	1/4"	USS-1/2"
5/16"	36673	1"	5/16"	SAE-1/2"	5/16"	USS-3/8"
	36674	1-1/4"	5/16"	SAE-5/8"	5/16"	USS-1/2"
	36675	1-1/2"	5/16"	SAE-5/8"	5/16"	USS-3/4"
	36676	1-3/4"	5/16"	SAE-7/8"	5/16"	USS-9/16"
	36677	2"	5/16"	SAE-1"	5/16"	USS-9/16"
	36678	2-1/2"	5/16"	SAE-1/2"	5/16"	USS-1/2"
	36679	1-1/2"	5/16"	USS-7/8"	5/16"	USS-7/16"
	36680	2"	5/16"	USS-1"	5/16"	USS-7/16"
	36681	3"	5/16"	SAE-1-1/2"	5/16"	USS-5/8"
	36683	1-1/2"	3/8"	SAE-3/4"	3/8"	USS-1/2"
3/8"	36684	1-3/4"	3/8"	SAE-3/4"	3/8"	USS-1/2"
	36686	2"	3/8"	SAE-1"	3/8"	USS-5/8"
	36687	2"	3/8"	USS-1-1/8"	3/8"	USS-5/8"
	36688	2-1/8"	3/8"	USS-1"	3/8"	USS-5/8"
	36689	2-3/4"	3/8"	SAE-1"	3/8"	USS-3/4"
	36690	3"	3/8"	SAE-2"	3/8"	USS-5/8"
	36692	3-1/4"	3/8"	USS-1-5/8"	3/8"	USS-7/16"
	36694	3-3/4"	3/8"	SAE-1"	3/8"	USS-3/4"
	36695	4"	3/8"	USS-2"	3/8"	USS-3/4"
	36696	4"	3/8"	SAE-1-7/8"	3/8"	USS-1/2"
7/16"	36697	1-1/2"	7/16"	SAE-3/4"	7/16"	USS-1/2"
	36698	1-3/4"	7/16"	USS-13/16"	7/16"	USS-3/4"
	36699	1-3/4"	7/16"	SAE-3/4"	7/16"	USS-9/16"
	36701	2"	7/16"	SAE-7/8"	7/16"	USS-3/4"
	36702	2"	7/16"	USS-15/16"	7/16"	USS-3/4"
	36705	2-1/4"	7/16"	SAE-3/4"	7/16"	USS-3/4"
	36706	2-1/4"	7/16"	SAE-7/8"	1/2"	USS-7/8"
	36708	2-1/2"	7/16"	SAE-7/8"	9/16"	USS-7/8"
	36709	2-1/2"	7/16"	SAE-7/8"	7/16"	USS-3/4"
	36711	2-1/2"	7/16"	USS-1-1/4"	7/16"	USS-3/4"
1/2"	36712	2-1/2"	7/16"	SAE-13/8"	7/16"	USS-3/4"
	36715	3"	7/16"	SAE-1-13/16"	7/16"	USS-3/4"
	36720	3-1/4"	7/16"	USS-1-7/8"	7/16"	USS-5/8"
	36721	3-1/4"	7/16"	SAE-3/4"	1/2"	USS-3/4"
	36726	1-3/4"	1/2"	SAE-5/8"	1/2"	USS-9/16"
	36727	1-7/8"	1/2"	SAE-3/4"	1/2"	USS-3/4"
	36728	2"	1/2"	SAE-5/16"	1/2"	USS-13/16"
	36729	2-1/4"	1/2"	SAE-1-1/8"	1/2"	USS-3/4"
	36730	2-3/8"	1/2"	SAE-7/8"	9/16"	USS-7/8"
	36731	2-1/2"	1/2"	SAE-1"	1/2"	USS-3/4"
9/16"	36732	3"	1/2"	SAE-2"	1/2"	USS-3/4"
	36734	3-3/4"	1/2"	SAE-1-1/4"	1/2"	USS-3/4"
	36738	2-1/2"	9/16"	SAE-1"	9/16"	USS-3/4"
	36739	3"	9/16"	SAE-1-1/4"	9/16"	USS-1"
5/8"	36742	2"	5/8"	SAE-3/4"	5/8"	USS-1/2"
	36743	2-1/2"	5/8"	SAE-1"	5/8"	USS-3/4"
	36744	2-5/8"	5/8"	USS-1-1/2"	5/8"	USS-13/16"
	36745	3"	5/8"	SAE-1-1/4"	5/8"	USS-1"
	36746	3-1/2"	5/8"	SAE-1-1/2"	5/8"	USS-1-1/4"
	36747	4"	5/8"	SAE-1-3/4"	5/8"	USS-1-1/2"
3/4"	36748	2-13/16"	3/4"	USS-1-9/16"	3/4"	USS-1-1/16"



## Retainer Clips & Rings

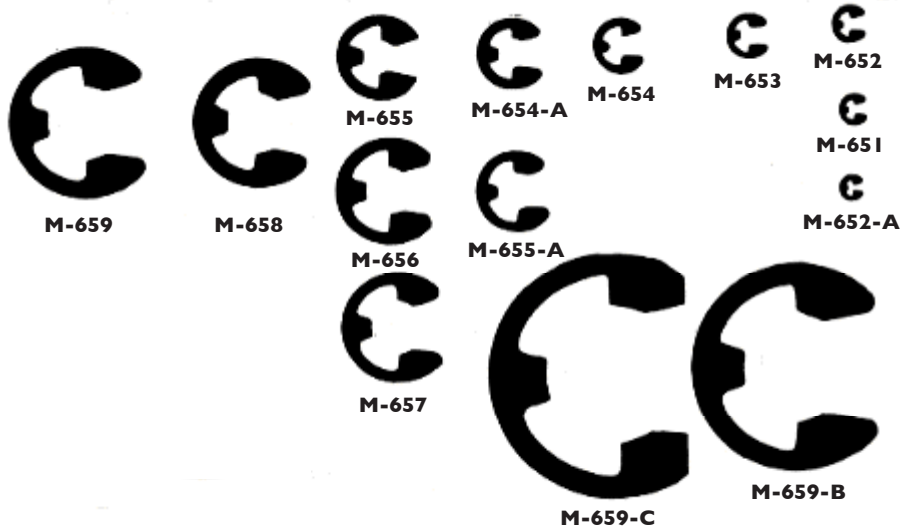

### "E" TYPE RETAINER CLIPS

Qual #	Shaft Dia.	Groove Dia.	Groove Width
M-652-A	1/16"	.052"	.012"
M-651	3/32"	.074"	.018"
M-652	1/8	.094"	.018"
M-653	5/32"	.114"	.029"
M-654	3/16"	.145"	.029"
M-654-A	7/32"	.185"	.029"
M-655	1/4	.207"	.029"
M-655-A	5/16"	.243"	.029"
M-656	3/8"	.300"	.039"
M-657	7/16"	.337"	.039"
M-658	1/2	.392"	.046"
M-659	5/8"	.042"	.046"

### "E" RING ASSORTMENT Qual #:A-1339

M-659-B	7/8"	.675"	.056"
M-659-C	1"	.835"	.056"

### REINFORCED "E" TYPE RETAINER RINGS

Qual#	Shaft Dia.	Groove Dia.	Groove Width
M-707	3/16"	.147"	.029"
M-708	1/4	.210"	.029"
M-709	5/16"	.250"	.039"
M-710	3/8"	.303"	.039"
M-711	7/16"	.343"	.039"
M-713	1/2	.396"	.046"
M-712	9/16"	.437"	.046"



### RETAINER CLIPS - RETAINING EXTERNAL RINGS Groove Required on Shaft

Qual #	Shaft Dia.	Groove Dia.	Groove Width	Qual #	Shaft Dia.	Groove Dia.	Groove Width
M-991	1/8"	.117"	.012"	M-1000	7/8"	.821"	.046"
M-991-B	3/16"	.170"	.029"	M-1045	15/16"	.882"	.046"
M-992	1/4	.230"	.029"	M-1001	1"	.940"	.046"
M-1040	9/32"	.261"	.029"	M-1046	1-1/16"	.998"	.056"
M-993	5/16"	.290"	.029"	M-1002	1-1/8"	1.059"	.056"
M-1041	11/32"	.321"	.029"	M-1047	1-3/16"	1.118"	.056"
M-994	3/8"	.352"	.029"	M-1003	1-1/4"	1.176"	.056"
M-1042	13/32"	.382"	.029"	M-1048	1-5/16"	1.176"	.056"
M-995	7/16"	.412"	.029"	M-1049	1-3/8"	1.285"	.056"
M-996	1/2	.468"	.039"	M-1050	1-7/16"	1.340"	.056"
M-997	9/16"	.530"	.039"	M-1051	1-1/2"	1.406"	.056"
M-1043	19/32"	.559"	.039"	M-1052	1-5/8"	1.525"	.068"
M-998	5/8"	.588"	.039"	M-1053	1-3/4"	1.650"	.068"
M-998-A	11/16"	.646"	.046"	M-1054	2"	1.886"	.068"
M-999	3/4	.704"	.046"	M-1055	2-1/4"	2.120"	.086"
M-1044	13/16"	.762"	.046"	M-1056	2-1/2"	2.360"	.086"

**SEE ASSORTMENTS:** External Ring Qual #:A-1238, Mixed Assortment of External and Internal Ring Qual #:A-1321



# External Retainer Rings

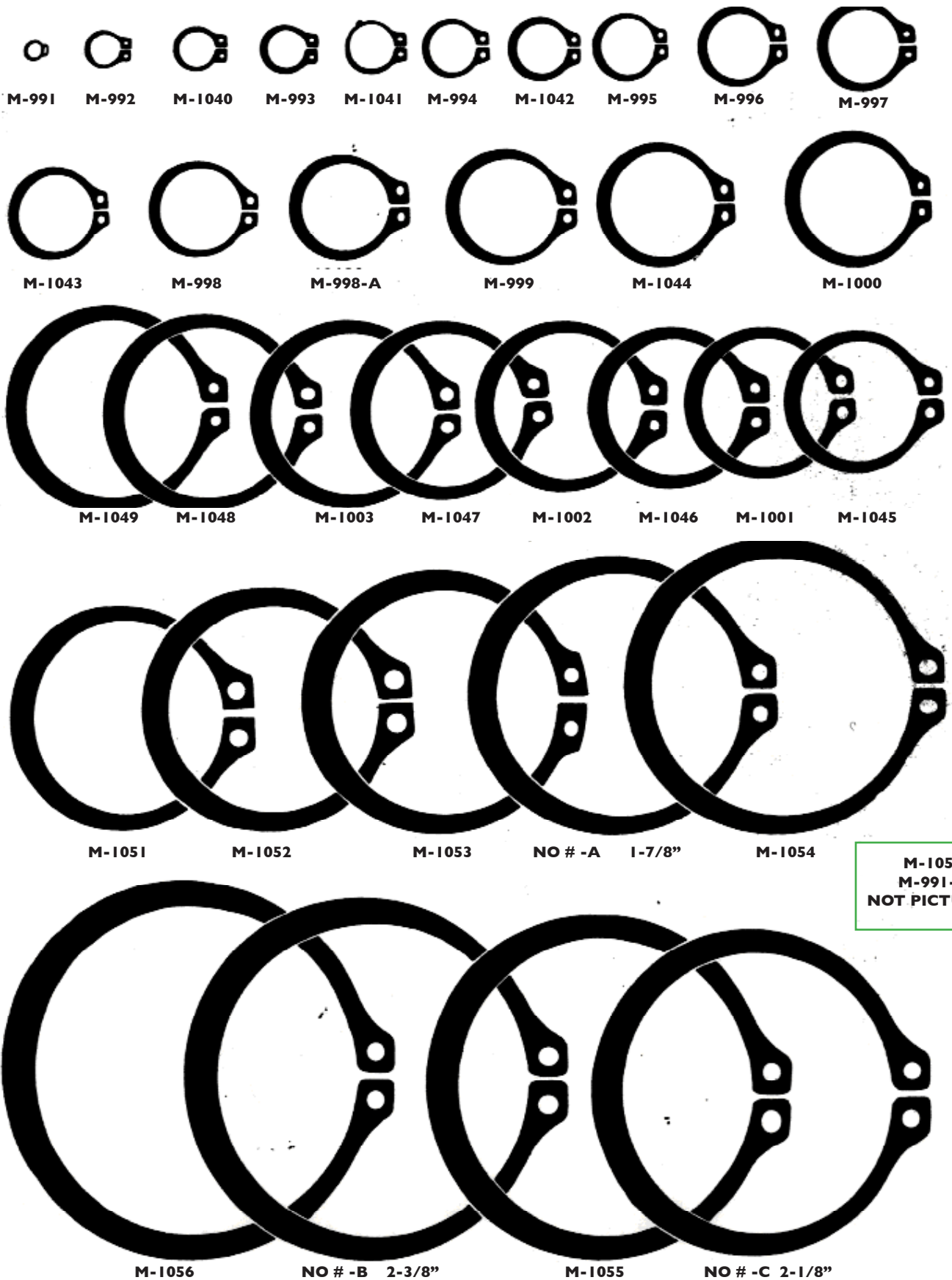

M-1050  
M-991-B  
NOT PICTURED

## Internal Retainer Rings

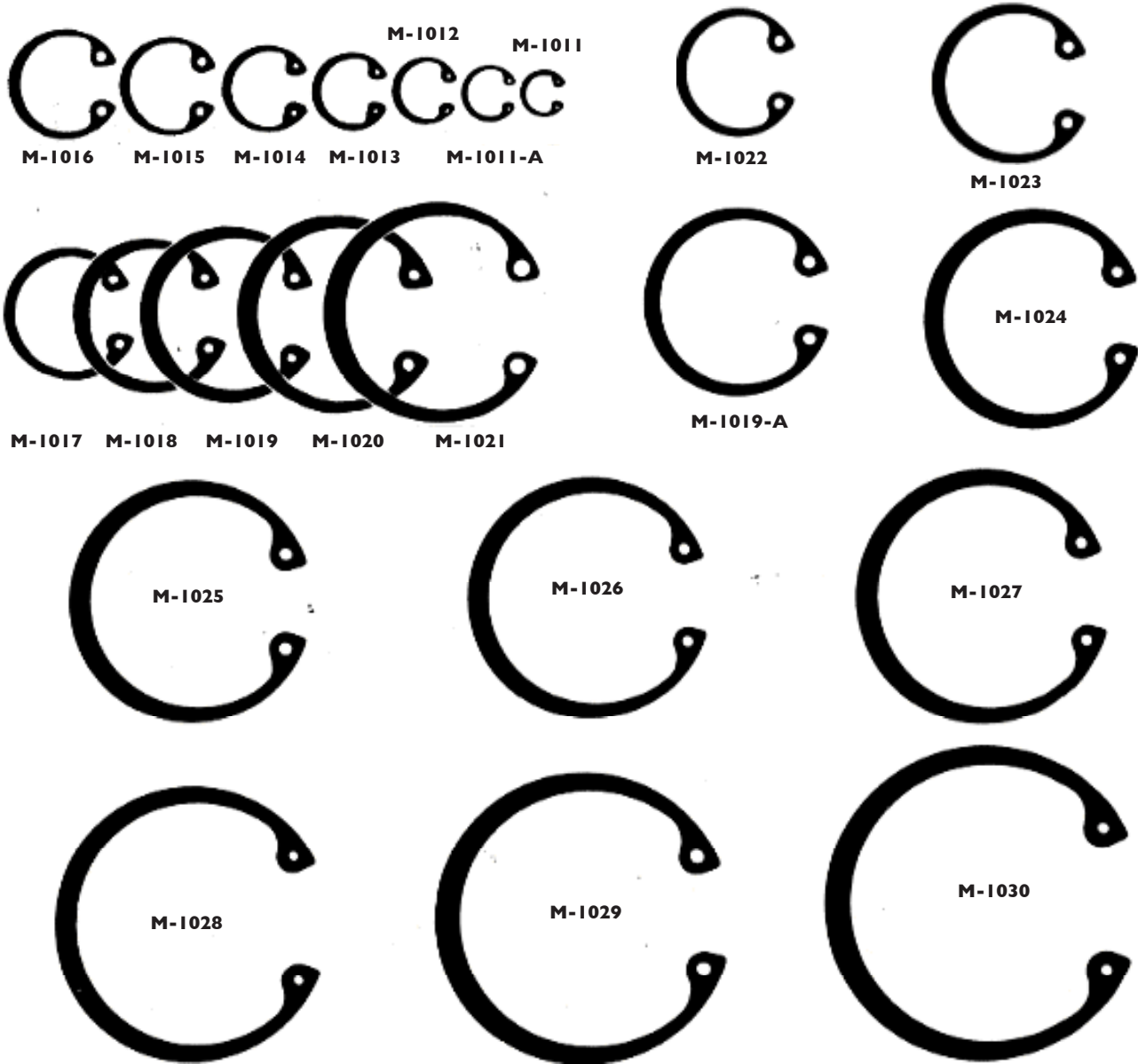

Qual #	Housing Dia.	Groove Dia.	Groove Width	Qual #	Housing Dia.	Groove Dia.	Groove Width
M-1011	1/4	.268"	.020"	M-1019	1"	1.066"	.046"
M-1011-A	5/16"	.330"	.020"	M-1019-A	1-1/16"	1.130"	.056"
M-1012	3/8"	.397"	.029"	M-1020	1-1/8"	1.197"	.056"
M-1013	7/16"	.461"	.029"	M-1024	1-3/16"	1.262"	.056"
M-1014	1/2	.530"	.039"	M-1021	1-1/4"	1.330"	.056"
M-1015	9/16"	.596"	.039"	M-1025	1-5/16"	1.396"	.056"
M-1016	5/8"	.665"	.039"	M-1026	1-3/8"	1.461"	.056"
M-1022	11/16"	.732"	.039"	M-1027	1-7/16"	1.528"	.056"
M-1017	3/4	.796"	.039"	M-1028	1-1/2"	1.594"	.056"
M-1023	13/16"	.862"	.046"	M-1029	1-5/8"	1.725"	.068"
M-1018	7/8"	.931"	.046"	M-1030	1-3/4"	1.858"	.068"
A-1239	ASSORTMENT						

# Storage Products

## Drawer Cabinets & Accessories

### 6 DRAW CABINET

Qual #: 9999



### DIVIDERS FOR DRAWER CABINETS

Qual #: 10003

### 18 DRAW CABINET

Qual #: 10002

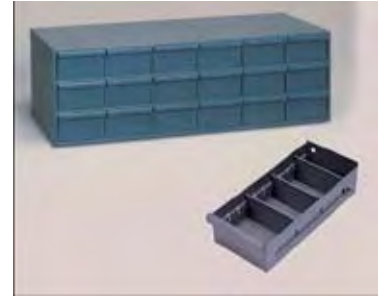

## Small Scoop Compartment Boxes & Racks - (13-3/8" x 9" x 2")

### 12 COMPARTMENT BOX WITH CATCH

Qual #: 10010



### 24 COMPARTMENT BOX WITH CATCH

Qual #: 10011



### COMPARTMENT BOX SLIDE RACK

Qual #: 10004

Holds 6 boxes.

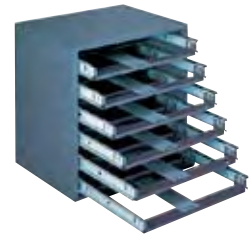

## Large Scoop Compartment Boxes & Racks - (18" x 12" x 3")

### 12 COMPARTMENT BOX WITH CATCH

Qual #: 10014



### 16 COMPARTMENT BOX WITH CATCH

Qual #: 10015



### 21 COMPARTMENT BOX WITH CATCH

Qual #: 10017



### 24 COMPARTMENT BOX WITH CATCH

Qual #: 10018



### ADJUSTABLE COMPARTMENT BOX WITH CATCH, DIVIDERS

Qual #: 10019



### HORIZONTAL 6 COMPARTMENT BOX WITH CATCH

Qual #: 10020



### 32 COMPARTMENT BOX WITH CATCH

Qual #: 10021



## Storage Products

### Racks & Bases for Large Scoop Compartment Boxes

**COMPARTMENT BOX SLIDE RACK**

Qual #: 10022  
Holds 4 boxes.



**COMPARTMENT BOX SLIDE RACK**

Qual #: 10023  
Holds 2 boxes.



**BASE FOR 10022 & 10023 RACK**

Qual #: 10033



### 12" Deep Bins and Base

**8 OPENING BIN**

Qual #: 10040



**16 OPENING BIN**

Qual #: 10041



**72 OPENING BIN**

Qual #: 10000



**40 OPENING BIN**

Qual #: 10001



**BASE**

Qual #: 10032

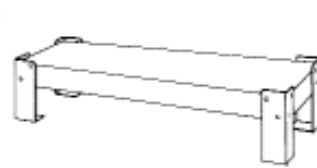

**LABELS FOR USE W/ PARTS BINS**

Qual #	Type
9994	Misc
9995	USS C/S
9996	SAE C/S
9998	Metric Labels



### Small Plastic Compartment Boxes - (11" x 6-3/4" x 1-1/4")

**6 COMPARTMENTS**

Qual #: 10045



**12 COMPARTMENTS**

Qual #: 10046

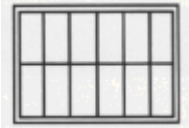

**18 COMPARTMENTS**

Qual #: 10047



### Miscellaneous Storage Items

**4 ROD WIRE SPOOL RACK**

Qual #: 10034



**AEROSOL CAN CADDY**

Qual #: 10005



**WELDING ROD CABINET**

Qual #: 10042

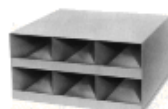

**KEY STOCK RACK**

Qual #: 10038



**THREADED ROD RACK**

Qual #: 10035



**CLEAR ASSORTMENT POUCHES**

Qual #: 9990  
For LARGE compartment Box

Qual #: 9991  
For SMALL compartment Box

# Thomas & Betts Products

## CABLE STRIPPING TOOL

Qual #: 1019



## REPLACEMENT BLADE FOR 1019

Qual #: 1019A

## REMOVING CABLE INSULATION

1. Push cable support bracket up with thumb and place cable within "V" of bracket so that end of cable is next to cutting blade, see Fig. 1

Adjust depth of cutting blade to thickness of cable insulation by turning the knurled screw, Fig. 1.

**NOTE:** care should be taken so that the cutting blade is not deep enough to nick or cut the strands of the cable. If the strands appear to be nicked or cut, the blade should be lowered to the proper depth.



FIG. 1

2. Determine the length of insulation to be removed and mark the point where the cut should be made. Push cable support bracket up with thumb, see Fig. 2. Insert the cable between "V" of cable support bracket and insulation cutting blade. Locate cable so that the mark is directly above the cutting blade.



FIG. 2

## NOTE: ALTERNATE METHOD, FIG.3

Hold stripping tool with end of cable support bracket facing you. Place cable under end of cable support bracket locating length of insulation to be removed directly in front of cutting blade. Pull stripping tool downward moving cable into the tool, under cable support bracket.



FIG. 3

3. Rotate stripping tool completely around the cable to cut the insulation; repeat rotation in reverse direction, see Fig 4



FIG. 4

4. Remove insulation by rotating lever to other end of slot. Hold it in that position, see Fig .5



FIG. 5

## CONNECTOR CRIMPING TOOL COLOR-KEYED DIES

Qual #: 1020



## CABLE SLICERS WITH FIBRE-GLASS HANDLES

Qual #: 1021



## BATTERY CRIMP TOOL

Qual #: 1026



## BATTERY PRODUCTS ORGANIZER KIT (Box only)

Qual #: 1174



## STA-KON INSTALLING TOOL

Qual #: 1023

All purpose precision tool with unique color-coded compression guide which visually indicates when correct crimp has been made. For insulated and non-insulated STA-KON terminals, disconnects, splices, and wire joints from #22 to 10 AWG, series A, B, C, RA, RB, RC, and PT. Also cuts wires, bolts, and cleans and reshapes threads. New scissor action wire stripper removes insulation cleanly, easily. Handles are spring loaded for convenience and ease of use.

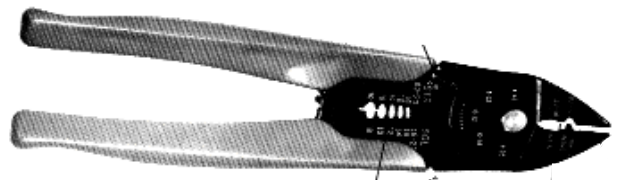



## Heat Shrink Tubing

### THIN WALL - FLEXIBLE POLYOLEFIN Bx 25

Flexible polyolefin heat shrink tubing recovers to 50% of its original diameter when heated. This material offers excellent chemical, corrosion, oil, and heat resistance. Typically used for wire bundling, wire marking, harnessing, and protecting wire connections.

Qual #	Pre-Shrink I.D.	Wire Range	Color & Length
1180	1/8"	22-18	Black & 6"
1181	3/16"	12-12	Black & 6"
1182	1/4"	12-8	Black & 6"
1183	3/8"	8-4	Black & 6"
1184	1/2"	6-2	Black & 6"

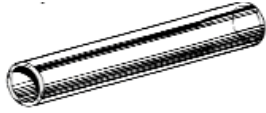

### HEAVY WALL - INSULATOR WITH SEALANT Bx 5

The heavy insulating wall thickens as it shrinks and protects against abrasion. The sealant flows over and around irregular surfaces, filling any voids as it moves, and seals out any moisture. The material is virtually chemically inert and it contains inhibitors which resist ultra violet rays. The product offers extremely long shelf life. Any 250° F minimum heat source can be used when installing the insulators.

Qual #	Mfg.#	Min.Exp I.D.	Max. Rec I.D.	Color	Length
1054	HS12-6LR	.400"	.150"	Red	6"
1055	HS12-6L	.400"	.150"	Black	6"
1056	HS-6IL	.750"	.220"	Black	9"
1057	HS-6ILR	.750"	.220"	Red	8"
1058	HS4-30L	1.100"	.375"	Black	9"
1059	HS-4-30LR	1.100"	.375"	Red	9"

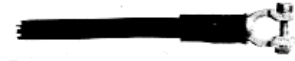

### LIGHTWEIGHT 1000°F ELECTRIC HEAT GUN

Qual #: 1176

Shrinks Heavy wall or Thin wall insulators - FAST.

Reaches full heat in less than 50 sec. Air deflector nozzle speeds shrinking. High-impact materials withstand rugged use. Snap-in stand for bench use. Durable, encapsulated ceramic heat element. Dual settings: 450°F and 1000°F. Protective cover over heat nozzle.



### SELF-IGNITING BLASTER MICRO TORCH

Qual #: 1177A

Butane powered. Flame temperature up to 2400°F



### SHRINK KON TORCH

For 14 or 16 oz. Cylinders

Qual #: 1175

Heavy Duty self-igniting torch. Instant single-handed ignition at any angle. Burns hot (over 3500°). Built in pressure regulator. Instant on/off. Trigger ignition lights torch automatically- no flints, batteries, or strikers to wear out. The body is constructed of strong, lightweight cast aluminum; burn tube & conduit of stainless steel; venturi, orifice & burn tips of solid brass. One tip used for heat shrink tubing, one for brazing and soldering

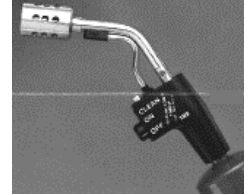

## Color-Keyed Copper Battery Cable Connectors, Starter Lugs and Cable Splicing Connectors

### STRAIGHT BATTERY CABLE CONNECTORS

Copper with Lead Plating  
Bx 10 (except 1044 Bx 5)

Qual#	SAE cable size	Polarity post or stud size	Color Code
1035	4	universal	Gray
1036	2	universal	Green
1037	1	universal	Pink
1038	1/0	positive	Black
1039	1/0	negative	Black
1040	2/0	positive	Orange
1041	2/0	negative	Orange
1042	3/0	positive	Purple
1043	3/0	negative	Purple
1044	4/0	universal	Yellow



### FLAG BATTERY CABLE CONNECTOR

Copper with Lead Plating - Bx 5

Qual #	SAE cable size	Polarity post or stud size	Color Code
1045	1/0	positive	Black
1046	1/0	negative	Black
1047	2/0	positive	Orange
1048	2/0	negative	Orange
1049	3/0	positive	Purple
1050	3/0	negative	Purple
1051	4/0	universal	Yellow



### STARTER LUGS

Copper with Tin Plating, Bx 10 (except 1085 Bx 5)

Qual #	SAE cable size	Polarity post or stud size	Color code
1070	4	1/4"	Gray
1071	4	5/16"	Gray
1072	4	3/8"	Gray
1073	2	3/8"	Green
1074	1"	3/8"	Pink
1075	1/0	3/8"	Black
1076	2/0	3/8"	Orange
1077	3/0	3/8"	Purple
1078	4/0	3/8"	Yellow
1080	2	1/2"	Green
1081	1	1/2"	Pink
1082	1/0	1/2"	Black
1083	2/0	1/2"	Orange
1084	3/0	1/2"	Purple
1085	4/0	1/2"	Yellow



## Color-Keyed Copper Battery Cable Connectors, Starter Lugs and Cable Splicing Connectors

### STARTER CABLE SPLICES

Copper with Tin Plating



Qual #	SAE Cable Size	Color Code	Box
1086	4	Gray	10
1087	2	Green	10
1088	1	Pink	10
1089	1/0	Black	5
1090	2/0	Orange	5
1091	3/0	Purple	5
1092	4/0	Yellow	5

### 3/8" THREADED STUD STYLE

Lead Plated, Annealed Copper, Anti Rotational, Box 10



Qua #	Cable Size	Color
1060	4 GA	Gray
1061	2 GA	Green
1062	1 GA	Pink
1063	1/0 GA	Black
1064	2/0 GA	Orange
1065	3/0 GA	Purple
1066	4/0 GA	Yellow

### "Y" SPLICES

Annealed Copper, Tin Plated Flared end accepts 2 wires

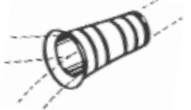

Qual #	Cable Size	Color
1067	2/0-(2) 2	Orange
1068	3/0-(2) 1	Purple
1069	4/0-(2) 1/0	Yellow

### RIGHT ELBOW, LEFT ELBOW, COLOR BANDS

Box 5

Right Elbow

Left Elbow

Color Bands

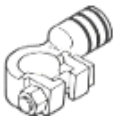
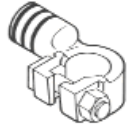

Qual #	Mfg #	Battery Cable Size	Color Code	Terminal Type
1093	BAC 1 0ERU	1/0	Black	Right elbow
1094	BAC 1 0ELU	1/0	Black	Left elbow
1095	BAC 2 0ERU	2/0	Orange	Right elbow
1096	BAC 2 0ELU	2/0	Orange	Left elbow
1097	BAC 3 0ERU	3/0	Purple	Right elbow
1098	BAC 3 0ELU	3/0	Purple	Left elbow

### INSTALLATION-UNIVERSAL CLAMP

Pkg 50

NOTE: Loop tie through hole in frame, around electrical, hydraulic, or air hoses to be clamped, and through head. Tighten and cut off with 1025 tool. Visually looks like a rivet.



Qual #	Max Dia.	Lgth	Tensile	Hole Size
1154	2.37"	9.6"	65#	.320-.680

### KOPR-SHIELD Pkg 12

Qual #: 1030, 8 oz. Can w/ brush

Qual #: 1031, 16 oz. Can w/ brush



A colloidal copper compound that protects, lubricates, and enhances electrical conductivity between mating surfaces. Extremely adhesive, Kopr-Shield compound flows smoothly into uneven contours, making application easy, protection & lubrication complete and positive. It will withstand temp. variations from -60 ° to 1800°F. and will not separate, settle-out, thin thicken, harden or dry out under the most severe conditions.

### COLOR-KEYED BATTERY CABLE AND STARTER CABLE

Qual # 25 foot	Qual # 100 foot	SAE gauge	Color Code
1100	1107	4	Gray
1101	1108	2	Green
1102	1109	1	Pink
1103	1110	1/0	Black
1104	1111	2/0	Orange
1105	1112	3/0	Purple
1106	1113	4/0	Yellow



Finally, a complete Color-Keyed battery/starter cable and connector system that's thorough and saves you time, money, inventory- and, most important of all, gets you vehicles back into service, quickly. Color bands on both connectors and dies quickly identify the correct installing die for positive compression. They also indicate exactly where compression should be used. Color-Keyed battery/starter cable & connector system from T&B Valon is the perfect choice: cable, connectors, starter lugs, insulators. Kopr-Shield corrosion resistant compound and Color-Keyed installation tooling, conforms to SAE specifications J1127.

### TY-RAP TOOL

Qual #: 1025

New hand operated, shirt pocket size cable tying tool. Made of high impact plastic and steel, absorbs shock and rough handling. Cinches up tie, and cuts away excess tail when twisted 180°.



### TY-RAP CABLE TIE ACCESSORIES

Qual #: 1162, Box 25

Pressure-sensitive mounting base for use with 13459 plastic Ty-Rap Ties. Base permits pre-assembly of cable ties prior to application.



### HEAVY DUTY TY-RAP LASHING TIE

Qual #: 1156



Ideally suited to indoor or outdoor applications that require strength, durability, and ease of installation. Made from black, ultraviolet resistant nylon, the tie retains its flexibility over an extreme temp. range from -40° to 225°F. Minimum tensile unlocking strength: 200 lbs. .500" width, 19" long.

### TY-RAP IDENTIFICATION TIES

Qual #: 1155, Self-locking  
7.25" Long, Dia. Range 3/8"- 1-3/4"



### TY-RAP MARKING PEN

Qual #: 1032,  
Makes a permanent legend  
Use on identification ties.

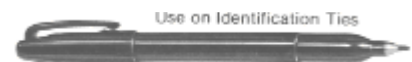

## TY-RAP Cable Ties

Qual#	Wire Bundle Range	Minimum Tensile Unlocking Strength	Width	Length	Installing Tool	Color
13458	1/16" to 5/8"	18 lbs.	.094"	3.62"		Natural
13460*	1/16" to 3"	40 lbs.	.140"	11.08"		Natural
13459*	1/16" to 1-3/4"	50 lbs.	.184"	7.31"v		Natural
12077	3/16" to 3-1/2"	120 lbs.	.301"	13.38"	1025	Natural
12081	1-1/2" to 9"	120 lbs.	.301"	30"	1025	Natural

\*12085 same size as 13459 except Black, \*13461-J same size as 13460 except Black

Qual#	Wire Bundle Range	Minimum Tensile Unlocking Strength	Width	Length	Installing Tool	Color
13558 mini	1/16-5/8"	18 lbs.	.100"	4.0"		Black
12185	1/16-1-3/4"	50lbs.	.187"	7.5"		Black
13559	1/16-1-3/4"	50lbs.	.187"	7.5"		Natural
13561	1/16-3"	40lbs.	.146"	11.5"		Black
13560	1/16-3"	40lbs.	.146"	11.5"		Natural
12177	3/16-4"	120lbs.	.300"	14.2"		Black
12181	3/16-7"	120lbs.	.300"	24.2"		Black

Qual#	Wire Bundle Range	Minimum Tensile Unlocking Strength	Mounting Hole Size	Width	Length	Color
12082	1/16" to 5/8"	18 lbs.	#4	.091"	4"	Natural
12078	1/16" to 1-3/4"	50 lbs.	#10	.184"	7.81"	Natural
12080	3/16"-3-1/2"	120 lbs.	1/4"	.301"	13.93"	Natural

Quantities per pkg as follows (-C) = 10 (-J) = 100 (-M) = 1000 (-G) = 25 (-H) = 50

## Drills

### SPLIT POINT TWIST DRILLS IN INDEX BOX

The unique features of Split Point Twist Drills and high strength steel provide instant, accurate starts **without** center-punching, cooler, faster drilling, less breakage and **without** constant re-sharpening.

Qual #: 20575

Fractional Size Drill Set.  
29 Drills in Index Box.  
1/16" to 1/2" by 64ths.



Qual #: 20578

Set of 60 drills in  
Index Box. Contains  
#1 to #60 Sizes.

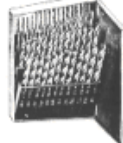

Qual #: 20577

Fractional Size Drill Set.  
15 Drills in Index Box.  
1/16" to 1/2" by 32nds.

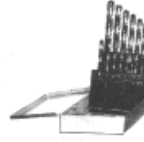

Qual #: 20574

Fractional Size Drill Set.  
13 Drills in Index Box.  
1/16" to 1/4" by 64ths.



### METRIC DRILL INDEXES

(available by special request)

Qual # Range

20874	1/16" to 1/4"	by 64ths
20563	1/16" to 1/2"	by 32nds
20875	1/16" to 1/2"	by 64ths
20876	#1 to 60 inc.	

### DRILL DISPENSERS

Qual #	Drill Type	Range	Drawers
20881	Fractional	1/16" to 1/2" by 64ths	3
20563	Number	#1 to 60 inc.	4
20875	Letter Drills	A to Z	3



### DRILL STANDS

Qual #	Range
20885	A to Z
20886	1/16" to 1/2" by 64ths
20887	#1 to 60 inc.



### STRAIGHT SHANK DRILLS FRACTIONAL SIZES



Qual #	Drill Diameter	Decimal Equival. in.	Overall Length	Qual #	Drill Diameter	Decimal Equival. in.	Overall Length	Qual #	Drill Diameter	Decimal Equival. in.	Overall Length
22455	1/16	.0625	1-7/8	22465	7/32	.2188	3-3/4	22475	3/8	.3750	5"
22456	5/64	.0781	2"	22466	15/64	.2344	3-7/8	22476	25/64	.3906	5-1/8
22457	3/32	.0938	2-1/4	22467	1/4	.2500	4"	22477	13/32	.4062	5-1/4
22458	7/64	.1094	2-5/8	22468	17/64	.2656	4-1/8	22478	27/64	.4219	5-3/8
22459	1/8	.1250	2-3/4	22469	9/32	.2812	4-1/4	22479	7/16	.4375	5-1/2
22460	9/64	.1406	2-7/8	22470	19/64	.2969	4-3/8	22480	29/64	.4531	5-5/8
22461	5/32	.1562	3-1/8	22471	5/16	.3125	4-1/2	22481	15/32	.4688	5-3/4
22462	11/64	.1719	3-1/4	22472	21/64	.3281	4-5/8	22482	31/64	.4844	5-7/8
22463	3/16	.1875	3-1/2	22473	11/32	.3438	4-3/4	22483	1/2	.5000	6"
22464	13/64	.2031	3-5/8	22474	23/64	.3594	4-7/8				

### LETTER SIZES

Jobber length, High Speed Steel, Straight Shank

Qual #	Size	Flute length	Overall Length
23119	A	2-5/8	3-7/8
23120	B	2-3/4	4
23121	C	2-3/4	4
23122	D	2-3/4	4
23123	E	2-3/4	4
23124	F	2-7/8	4-1/8
23125	G	2-7/8	4-1/8
23126	H	2-7/8	4-1/8
23127	I	2-7/8	4-1/8
23128	J	2-7/8	4-1/8
23129	K	2-15/16	4-1/4
23130	L	2-15/16	4-1/4
23131	M	3-1/16	4-3/8
23132	N	3-1/16	4-3/8
23133	O	3-3/16	4-1/2
23134	P	3-5/16	4-5/8
23135	Q	3-7/16	4-3/4
23136	R	3-7/16	4-3/4
23137	S	3-1/2	4-7/8
23138	T	3-1/2	4-7/8
23139	U	3-5/8	5
23140	V	3-5/8	5
23141	W	3-3/4	5-1/8
23142	X	3-3/4	5-1/8
23143	Y	3-7/8	5-1/4
23144	Z	3-7/8	5-1/4

### SILVER & DEMING DRILLS

135° Split Point 1/2 Shank

Qual #	Dia.	Decimal Equiv. Inches	Length of Flute	Overall Length
22508	33/64	.5156	3"	6"
22492	17/32	.5312	3"	6"
22493	9/16	.5625	3"	6"
22509	37/64	.5781	3"	6"
22494	19/32	.5938	3"	6"
22495	5/8	.6250	3"	6"
22496	21/32	.6562	3"	6"
22497	11/16	.6875	3"	6"
22510	45/64	.7031	3"	6"
22498	23/32	.7188	3"	6"
22499	3/4	.7500	3"	6"
22500	25/32	.7812	3"	6"
22501	13/16	.8125	3"	6"
22511	53/64	.8281	3"	6"
22502	27/32	.8438	3"	6"
22503	7/8	.8750	3"	6"
22504	29/32	.9062	3"	6"
22505	15/16	.9375	3"	6"
22506	31/32	.9688	3"	6"
22507	1	1.000	3"	6"
22520	1-1/16	1.0625	3	6-1/2"
22521*	1-1/8	1.1250	3"	6-1/2"
22522*	1-1/4	1.2500	3"	6"

\*These sizes not avail. With 135° split point.



Specially designed for 1/2" capacity drill chucks. Holes can be drilled from 33/64" thru 1" diameter using only one size drill motor. Self-centering point available on 1/2" shank drills

### CARBIDE TIP DRILLS

**Deep Flute**, Industrial Grade, Hardened Body, Regular Length



Qual #	Size	Shank Dia.	Overall Lgth.
22804	1/8	1/8	2-1/2
22805	3/16	3/16	3
22806	1/4	1/4	4
22807	5/16	1/4	4
22808	3/8	1/4	4
22809	7/16	1/4	4

**Straight Flute**, use for drilling hard steels where precision is not necessary.



Qual #	Dia.	Dec. Equiv	Flute Lgth.	Overall Lgth.
22810	1/8	.1250	1-1/2	2-3/4
22811	3/16	.1875	1-7/8	3
22812	1/4	.2500	2-1/2	4
22813	1/4	.2500	4-1/4	6
22814	5/16	.3125	2-1/2	4
22815	3/8	.3750	4	6
22816	1/2	.5000	4	6

**Fast Spiral**, Industrial Grade Hardened Body, Regular Length.



Qual#	Size	Shank Dia.	Overall Lgth.
22800	3/16	3/16	3
22801	1/4	1/4	4
22802	5/16	1/4	4
22803	3/8	1/4	4

### METRIC HIGH SPEED DRILLS



Qual #	Size	Overall Lgth.
23146	1mm	1-3/8
23147	1.5mm	1-5/8
23148	2mm	2
23149	2.5mm	2-1/4
23150	3mm	2-3/8
23151	3.5mm	2-7/8
23152	4mm	3
23153	4.5mm	3-1/4
23154	5mm	3-1/2
23155	5.5mm	3-5/8
23156	6mm	3-5/8
23157	6.5mm	4
23158	7mm	4-3/8
23159	7.5mm	4-3/8
23160	8mm	4-5/8
23161	8.5mm	4-5/8
23162	9mm	5
23163	9.5mm	5
23164	10mm	5-1/4

### HOLE SAW PILOT DRILL

Qual #: 22820

3 Slab, Bright Finish, Size 1/4, Dec. Length .2500, Flute 1-1/4", Overall Length 4"



### QUALITY PRO-CUT REAMERS

Specially designed to save labor time when drilling, trueling, aligning, and deburring holes in structural steel members encountered in construction, automotive, and truck maintenance and fabrication. If it use to take hours, it'll only take minutes with this unique cutting tool.



- **Shorter Length:** For easy use in confined quarters, Reduced Breakage
- **Flute Geometry:** Left hand fast spiral, right hand cut; Developed for high speed operation.
- **Material:** Special high speed steel, heat treated and tempered to reduce breakage and chipping by increasing toughness.
- **Straight Shank:** Fits any 3 jaw chuck power tool with 1/2" capacity.
- **Collar Stop:** Prevents over penetration of hole and facilitates withdrawal of tool.
- **Use a Qual #:** 22471 5/16 Split Point as a pilot hole for 1/2" reamer. To drill 5/8" and 3/4" hole, use 1/2". Pro-cut Reamer as intermediate step. BK-360 Cutting Tool Coolant is an integral part of the system. The tool must be sprayed constantly when in use.
- **ASST 24785 available.** Contains 1 EA. 1/2", 5/8", 3/4" Reamers. 2 Cans BK-360 Cutting Tool Coolant

Qual #	Diameter	OA Length	Shank Lgth	Shank Dia.	Body Lgth	Flutes
24790	3/8	4-3/4	1-1/4	25/64	3-1/2	5
24782	1/2	5-7/8	1-3/8	1/2	4"	5
24781	9/16			9/16		5
24783	5/8	6-1/4	1-3/8	1/2	4-1/2	5
24784	3/4	6-3/4	1-3/8	1/2	5"	5
24786	7/8	7-1/4	1-3/8	1/2	5-1/2	5
24787	1"	7-1/4	1-3/8	1/2	5-1/2	5

### 1/4 INCH SHANK DRILL

Specially designed for 1/4" and 3/8" capacity drill chucks. Holes can be drilled from 9/32" thru 1/2" diameter using only one size drill chuck. Self-centered point on all sizes provides faster start and eliminates need for center-punching.



Qual #	Dia.	Dec. Equiv	Flute Lgth.	Overall Lgth.
22484	9/32	.2812	2-1/4	3-19/32
22485	5/16	.3125	2-1/2	3-27/32
22486	11/32	.3438	2-5/8	4-1/32
22487	3/8	.3750	2-7/8	4-1/4
22488	13/32	.4062	3-1/8	4-15/32
22489	7/16	.4375	3-3/8	4-11/16
22490	15/32	.4688	3-1/2	4-7/8
22491	1/2	.5000	3-5/8	5-3/32

# Drills

**WIRE GAUGE SIZES** Jobber Length, High Speed Steel, Straight Shank. Pkg. Ea.



Qual #	Size	Flute Lgth	Overall Lgth	Qual #	Size	Flute Lgth	Overall Lgth	Qual #	Size	Flute Lgth	Overall Lgth
23059	1	2-5/8"	3-7/8"	23079	21	2-1/8"	3-1/4"	23099	41	1-3/8"	2-3/8"
23060	2	2-5/8"	3-7/8"	23080	22	2"	3-1/8"	23100	42	1-1/4"	2-1/4"
23061	3	2-1/2"	3-3/4"	23081	23	2"	3-1/8"	23101	43	1-1/4"	2-1/4"
23062	4	2-1/2"	3-3/4"	23082	24	2"	3-1/8"	23102	44	1-1/8"	2-1/8"
23063	5	2-1/2"	3-3/4"	23083	25	1-7/8"	3"	23103	45	1-1/8"	2-1/8"
23064	6	2-1/2"	3-3/4"	23084	26	1-7/8"	3"	23104	46	1-1/8"	2-1/8"
23065	7	2-7/16"	3-5/8"	23085	27	1-7/8"	3"	23105	47	1"	2"
23066	8	2-7/16"	3-5/8"	23086	28	1-3/4"	2-7/8"	23106	48	1"	2"
23067	9	2-7/16"	3-5/8"	23087	29	1-3/4"	2-7/8"	23107	49	1"	2"
23068	10	2-7/16"	3-5/8"	23088	30	1-5/8"	2-3/4"	23108	50	1"	2"
23069	11	2-5/16"	3-1/2"	23089	31	1-5/8"	2-3/4"	23109	51	1"	2"
23070	12	2-5/16"	3-1/2"	23090	32	1-5/8"	2-3/4"	23110	52	7/8"	1-7/8"
23071	13	2-5/16"	3-1/2"	23091	33	1-1/2"	2-5/8"	23111	53	7/8"	1-7/8"
23072	14	2-3/16"	3-3/8"	23092	34	1-1/2"	2-5/8"	23112	54	7/8"	1-7/8"
23073	15	2-3/16"	3-3/8"	23093	35	1-1/2"	2-5/8"	23113	55	7/8"	1-7/8"
23074	16	2-3/16"	3-3/8"	23094	36	1-7/16"	2-1/2"	23114	56	3/4"	1-3/4"
23075	17	2-3/16"	3-3/8"	23095	37	1-7/16"	2-1/2"	23115	57	3/4"	1-3/4"
23076	18	2-1/8"	3-1/4"	23096	38	1-7/16"	2-1/2"	23116	58	11/16"	1-5/8"
23077	19	2-1/8"	3-1/4"	23097	39	1-3/8"	2-3/8"	23117	59	11/16"	1-5/8"
23078	20	2-1/8"	3-1/4"	23098	40	1-3/8"	2-3/8"	23118	60	11/16"	1-5/8"

**COBALT - TYPE J** List N0. 705C, Straight Shank, 135° Split Point, Gold Oxide.

Qual #	Size	Dec.Equiv	Flute Lgth.	Overall Lgth	Qual #	Size	Dec.Equiv	Flute Lgth.	Overall Lgth
22712	1/64"	.0156	3/16"	3/4"	22728	17/64"	.2656	2-7/8"	4-1/8"
22713	1/32"	.0312	1/2"	1-3/8"	22729	9/32"	.2812	2-15/16"	4-1/4"
22714	3/64"	.0469	3/4"	1-3/4"	22730	19/64"	.2969	3-1/16"	4-3/8"
22715	1/16"	.0625	7/8"	1-7/8"	22731	5/16"	.3125	3-3/16"	4-1/2"
22716	5/64"	.0781	1"	2"	22732	21/64"	.3281	3-5/16"	4-5/8"
22717	3/32"	.0938	1-1/4"	2-1/4"	22733	11/32"	.3438	3-7/16"	4-3/4"
22718	7/64"	.1094	1-1/2"	2-5/8"	22734	23/64"	.3594	3-1/2"	4-7/8"
22719	1/8"	.1250	1-5/8"	2-3/4"	22735	3/8"	.3750	3-5/8"	5"
22720	9/64"	.1406	1-3/4"	2-7/8"	22736	25/64"	.3906	3-3/4"	5-1/8"
22721	5/32"	.1562	2"	3-1/8"	22737	13/32"	.4062	3-7/8"	5-1/4"
22722	11/64"	.1719	2-1/8"	3-1/4"	22738	27/64"	.4219	3-15/16"	5-3/8"
22723	3/16"	.1875	2-5/16"	3-1/2"	22739	7/16"	.4375	4-1/16"	5-1/2"
22724	13/64"	.2031	2-7/16"	3-5/8"	22740	29/64"	.4531	4-3/16"	5-5/8"
22725	7/32"	.2188	2-1/2"	3-3/4"	22741	15/32"	.4688	4-5/16"	5-3/4"
22726	15/64"	.2344	2-5/8"	3-7/8"	22742	31/64"	.4844	4-3/8"	5-7/8"
22727	1/4"	.2500	2-3/4"	4"	22743	1/2"	.5000	4-1/2"	6"

## LEFT HAND DRILL BITS

Assortment 20524 Consists of 7 drills, one of each size. A 15 hole index is used for this asst.

Qual #	Diameter	Dec. Equiv	Overall Lgth
20525	1/8	.1250	2-3/4
20526	5/32	.1562	3-1/8
20527	3/16	.1875	3-1/2
20528	7/32	.2188	3-3/4
20529	1/4	.2500	4
20530	5/16	.3125	4-1/2
20531	3/8	.3750	5

## SINGLE END SHORTIES

Heavy Duty, Overall Length 2"



Qual #	Size	Dec. Equiv	Flute Lgth
22610	1/8	.1250	1/2
22611	5/32	.1562	1/2

## 1 1/2" LONGBOY DRILLS

High Speed Steel, 118° Point, Bright Finish

Qual #	Size	Dec. Equiv	Flute Lgth.
22600	3/16	.1875	9"
22601	7/32	.2187	9"
22602	1/4	.2500	9"
22603	5/16	.3125	9"

## DOUBLE END SHORTIES

Heavy Construction, 135° Split Point, Surface Treated, Overall Length 2"



Qual #	Size	Dec. Equiv	Flute Lgth
22615	1/8	.1250	1/2
22620	1/4	.250	1/2



Qual #	Size	Dec. Equiv	Flute Lgth.
22604	3/8	.3750	9"
22605	7/16	.4375	9"
22606	1/2	.5000	9"

## Taps & Dies

### FRACTIONAL NATIONAL TAPS



Taper Style			Plug Style			Bottoming Style		
Qual #	Size		Qual #	Size		Qual #	Size	
22629	1/4-20	NC	24556	1/4-20	NC	24576	1/4-20	NC
22630	1/4-28	NF	24557	1/4-28	NF	24577	1/4-28	NF
22631	5/16-18	NC	24558	5/16-18	NC	24578	5/16-18	NC
22632	5/16-24	NF	24559	5/16-24	NF	24579	5/16-24	NF
22633	3/8-16	NC	24560	3/8-16	NC	24580	3/8-16	NC
22634	3/8-24	NF	24561	3/8-24	NF	24581	3/8-24	NF
22635	7/16-14	NC	24562	7/16-14	NC	24582	7/16-14	NC
22636	7/16-20	NF	24563	7/16-20	NF	24583	7/16-20	NF
22637	1/2-13	NC	24564	1/2-13	NC	24584	1/2-13	NC
22638	1/2-20	NF	24565	1/2-20	NF	24585	1/2-20	NF
22639	9/16-12	NC	24566	9/16-12	NC	24586	9/16-12	NC
22640	9/16-18	NF	24567	9/16-18	NF	24587	9/16-18	NF
22641	5/8-11	NC	24568	5/8-11	NC	24588	5/8-11	NC
22642	5/8-18	NF	24569	5/8-18	NF	24589	5/8-18	NF
22643	3/4-10	NC	24570	3/4-10	NC	24590	3/4-10	NC
22644	3/4-16	NF	24571	3/4-16	NF	24591	3/4-16	NF
22645	7/8-9	NC	24572	7/8-9	NC	24592	7/8-9	NC
22646	7/8-14	NF	24573	7/8-14	NF	24593	7/8-14	NF
22647	1-8	NC	24574	1-8	NC	24594	1-8	NC
22648	1-14	NS	24575	1-14	NS	24595	1-14	NS
22821	1-12	NF	22824	1-12	NF	22827	1-12	NF
22822	1-1/8-12	NF	22825	1-1/8-12	NF	22828	1-1/8-12	NF
24670	1-1/8-7	NC	24675	1-1/8-7	NC	24680	1-1/8-7	NC
24671	1-1/4-7	NC	24676	1-1/4-7	NC	24681	1-1/4-7	NC
24672	1-1/4-12	NF	24677	1-1/4-12	NF	24682	1-1/4-12	NF
22823	1-3/8-12	NF	22826	1-3/8-12	NF	22829	1-3/8-12	NF
22823A	1-3/8-6	NC	22826A	1-3/8-6	NC	22829A	1-3/8-6	NC
24673	1-1/2-6	NC	24678	1-1/2-6	NC	24683	1-1/2-6	NC
24674	1-1/2-12	NF	24679	1-1/2-12	NF	24684	1-1/2-12	NF

### HEX RE-THREADING DIES

List No. 330, Right Hand, Standard Sizes.



Qual #	Size		Size Across Flats	Die Thickness
22700	6-32	NC	19/32	1/4
22701	8-32	NC	19/32	1/4
22702	10-24	NC	19/32	1/4
22703	10-32	NF	19/32	1/4
22704	12-24	NC	19/32	1/4
22664	1/4-20	NC	19/32	1/4
22665	1/4-28	NF	19/32	1/4
22666	5/16-18	NC	11/16	5/16
22667	5/16-24	NF	11/16	5/16
22668	3/8-16	NC	25/32	3/8
22669	3/8-24	NF	25/32	3/8
22670	7/16-14	NC	7/8	7/16
22671	7/16-20	NF	7/8	7/16
22672	1/2-13	NC	1-1/16	1/2
22673	1/2-20	NF	1-1/16	1/2
22674	9/16-12	NC	1-1/16	1/2
22675	9/16-18	NF	1-1/16	1/2
22676	5/8-11	NC	1-1/4	5/8
22677	5/8-18	NF	1-1/4	5/8
22678	3/4-10	NC	1-7/16	3/4
22679	3/4-16	NF	1-7/16	3/4
22680	7/8-9	NC	1-5/8	7/8
22681	7/8-14	NF	1-5/8	7/8
22682	1-8	NC	1-13/16	1
22683	1-12	NF	1-13/16	1
22705	1-14	NS	1-13/16	1

### MACHINE SCREW TAPS



Taper Style			Plug Style			Bottoming Style		
Qual #	Size		Qual #	Size		Qual #	Size	
22622	4-36	NC	24542	4-40	NC	24549	4-40	NC
22623	4-40	NF	24543	4-48	NF	24550	4-48	NF
22624	6-32	NC	24544	6-32	NC	24551	6-32	NC
22625	8-32	NC	24545	8-32	NC	24552	8-32	NC
22626	10-24	NC	24546	10-24	NC	24553	10-24	NC
22627	10-32	NF	24547	10-32	NF	24554	10-32	NF
22628	12-24	NC	24548	12-24	NC	24555	12-24	NC

### PIPE TAPS

Qual #	Size	No. of Flutes	Lgth of Thread	Overall Lgth
22651	1/8-27	4	3/4	2-1/8
22652	1/4-18	4	1-1/16	2-7/16
22653	3/8-18	4	1-1/16	2-9/16
22654	1/2-14	4	1-3/8	3-1/8
22655	3/4-14	5	1-3/8	3-1/4
22656	1-11/2	5	1-3/4	3-3/4



### SPIRAL POINT GROUND THREAD

Made to H3 limits, Surface Treated, Three Flute, Heavy Duty, Necked Shank, Special Steel. PLUG Style



Qual #	Size		Lgth of Thread	Overall Lgth
22830	6-32	NC	11/16	2
22831	8-32	NC	3/4	2-1/8
22832	10-24	NC	7/8	2-3/8
22833	10-32	NF	7/8	2-3/8
22834	12-24	NC	15/16	2-3/8
22835	1/4-20	NC	1	2-1/2
22836	1/4-28	NF	1	2-1/2
22837	5/16-18	NC	1-1/8	2-23/32
22838	5/16-24	NF	1-1/8	2-23/32
22839	3/8-16	NC	1-1/4	2-15/16
22840	3/8-24	NF	1-1/4	2-15/16
22841	7/16-14	NC	1-7/16	3-5/32
22842	7/16-20	NF	1-7/16	3-5/32
22843	1/2-13	NC	1-21/32	3-3/8
22844	1/2-20	NF	1-21/32	3-3/8
22845	5/8-11	NC	1-13/16	3-13/16
22846	3/4-10	NF	2	4-1/4



### 3-PIECE TAP SETS

High Carbon Steel, Standard "H" Limits, Standard number of Flutes. Contains 1 each of the following Taps: Taper, Plug & Bottoming Style in sizes indicated

Qual #	Size		Qual #	Size		Qual #	Size	
24596	4-40	NC	24608	3/8-16	NC	24619	3/4-16	NF
24597	4-48	NF	24609	3/8-24	NF	24620	7/8-9	NC
24598	6-32	NC	24610	7/16-14	NC	24621	7/8-14	NF
24599	8-32	NC	24611	7/16-20	NF	24622	1-8	NC
24600	10-24	NC	24612	1/2-13	NC	24623	1-14	NS
24601	10-32	NF	24613	1/2-20	NF	24659	1-12	NF
24602	12-24	NC	24614	9/16-12	NC	24660	1-1/8-12	NF
24603	1/4-20	NC	24615	9/16-18	NF	24661	1-3/8-12	NF
24604	1/4-28	NF	24616	5/8-11	NC			
24605	5/16-18	NC	24617	5/8-18	NF			
24606	5/16-24	NF	24618	3/4-10	NC			

### SCREW EXTRACTOR SETS

Qual #: 24812

Consists of 1 EA., Sizes #1 to #6, Packed in durable Vinyl Pouch.

### SCREW EXTRACTORS

Spiral Flute Type



Qual #	Size	Dia. Small End	Dia. Large End	For Bolt Sizes	For Pipe Sizes	Drill Size
24800	1	.054	5/32	3/16 to 1/4		5/64
24801	2	.080	3/16	1/4 to 5/16		7/64
24802	3	1/8	1/4	5/16 to 7/16		5/32
24803	4	3/16	21/64	7/16 to 9/16		1/4
24804	5	1/4	7/16	9/16 to 3/4	1/8, 1/4	17/64
24805	6	3/8	19/32	3/4 to 1	3/8	13/32
24806	7	1/2	3/4	1 to 1-3/8	1/2	17/32
24807	8	3/4	1	1-3/8 to 1-3/4	3/4	13/16
24808	9	1	1-9/32	1-3/4 to 2-1/8	1	1-1/16
24809	10	1-1/4	1-9/16	2-1/8 to 2-1/2	1-1/4	1-5/16
24810	11	1-1/2	1-7/8	2-1/2 to 3	1-1/2	1-9/16
24811	12	1-7/8	2-15/16	3 to 3-1/2	2	1-15/16

### UNIBIT DRILL

Qual #: 24815

Drills, 13 Sizes from 1/8 to 1/2



Qual #: 24816

Drills, 8 Sizes from 9/16 to 1 for 1/2" Shank Drill



### SPIRAL POINT METRIC SIZES

PLUG Style, Standard number of Flutes, Ground Thread

Qual#	Size	Pitch Dia. Limits	No. of Flutes	Lgh of Thread	Overall Length
22850	3 x 0.5	D3	2	5/8	1-15/16
22851	3.5 x .06	D4	2	1 1/16	2
22852	4 x 0.7	D4	2	3/4	2-1/8
22853	5 x 0.8	D4	2	7/8	2-3/8
22854	6 x 1.0	D5	2	1	2-1/2
22855	6.3 x 1.0	D5	2	1	2-1/2
22856	8 x 1.25	D5	2	1-1/8	2-23/32
22857	10 x 1.5	D6	3	1-1/4	2-15/16
22858	12 x 1.75	D6	3	1-21/32	3-3/8
22859	14 x 2.0	D7	3	1-21/32	3-19/32
22860	16 x 2.0	D7	3	1-13/16	3-13/16



- 1- 1/8
- 2- 5/32
- 3- 3/16
- 4- 7/32
- 5- 1/4
- 6- 9/32
- 7- 5/16
- 8- 11/32
- 9- 3/8
- 10- 13/32
- 11- 7/16
- 12- 15/32
- 13- 1/2

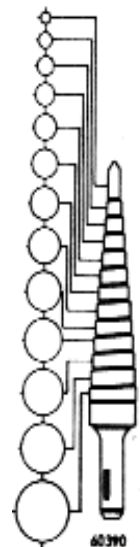

## Washers

### FLAT WASHERS PLATED USS



Qual # 2lbs	Qual # 5lbs	Bolt Size (in.)	I.D. (in.)	O.D. (in.)	APPROX. PC./LB.
43200		3/16	1/4	9/16	400
43201	43226	1/4	5/16	3/4	149
43202	43227	5/16	3/8	7/8	90
43203	43228	3/8	7/16	1	75
43204	43229	7/16	1/2	1-1/4	41
43205	43230	1/2	9/16	1-3/8	26
43206	43231	9/16	5/8	1-1/2	22
43207	43232	5/8	11/16	1-3/4	13
43208	43233	3/4	13/16	2	10
43209	43234	7/8	15/16	2-1/4	7
43210	43235	1	1-1/16	2-1/2	5
	43236	1-1/8	1-1/4	2-3/4	
	43237	1-1/4	1-3/8	3	
	43238	1-1/2	1-5/8	3-1/2	

### ASSORTMENT USS FLAT

Qual #: 43239

3/16" thru 1/2" in impact-resistant plastic box.

### FLAT WASHERS PLATED SAE



Qual # 2lbs	Qual # 5lbs	Bolt Size (in.)	I.D. (in.)	O.D. (in.)	APPROX. PC./LB.
43250		#6	5/32	3/8	790
43251		#8	3/16	7/16	600
43252		3/16	7/32	1/2	435
43253	43278	1/4	9/32	5/8	222
43254	43279	5/16	11/32	11/16	192
43255	43280	3/8	13/32	13/16	140
43256	43281	7/16	15/32	59/64	105
43257	43282	1/2	17/32	1-1/16	55
43258	43283	9/16	19/32	1-3/16	45
43259	43284	5/8	21/32	1-5/16	36
43260	43285	3/4	13/16	1-1/2	25
43261	43286	7/8	15/16	1-3/4	16
43262	43287	1	1-1/16	2	12
	43288	1-1/8	1-3/16	2-1/4	

### ASSORTMENT SAE FLAT

Qual #: 43291

#10 thru 1/2" in impact-resistant plastic box

### ALLOY STEEL WASHERS USS GRADE 8 FLAT

Yellow Dichromate Plated

Qual #	Size	Bx
8561	1/4	100
8562	5/16	100
8563	3/8	100
*8564	7/16	50
*8565	1/2	50
*8566	9/16	50
*8567	5/8	25
*8568	3/4	25
8569	7/8	20
8570	1	10
8571	1-1/8	10
8572	1-1/4	10
8573	1-1/2	5

### ALLOY STEEL WASHERS SAE GRADE 8 FLAT

Yellow Dichromate Plated

Qual #	Size	Bx
8548	1/4	100
8549	5/16	100
8550	3/8	100
*8551	7/16	50
*8552	1/2	50
*8553	9/16	50
*8554	5/8	25
*8555	3/4	25
8556	7/8	20
8557	1	10
		* (-1) # Bx/ 100
		□ (-2) # Bx/ 200

### TENSION CONTROL LAMALLOY L9 FLAT

Yellow Dichromate Plated

Qual #	Size	Bx
8460	1/4	100
8461	5/16	100
8462	3/8	100
8463	7/16	50
8464	1/2	50
8465	9/16	50
8466	5/8	50
8467	3/4	50
8468	7/8	25
8469	1	25
8470	1-1/8	10
8471	1-1/4	10
8472	1-1/2	10

### SPRING WASHERS

Black Finish

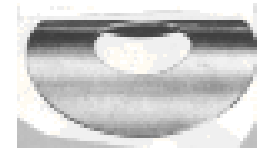

Qual #	Size
43111	1/4
43112	5/16
43113	3/8
43114	7/16
43115	1/2
43116	Asst. 5 sizes in box

### LOCK WASHERS Plated

Qual #	Bx	Size	Qual #	Bx	Size	Qual #	Bx	Size
43029	100	#4	--	--	--	43012	50	7/8
43000	100	#6	43020		#6	43013	50	1
43001	100	#8	43021		#8	43014	10	1-1/18
43002	100	#10	43022		#10	43015	10	1-1/4
43003	100	#12	--	--	--	43016	10	1-1/2
43004	100	1/4	43023		1/4			
43005	100	5/16	43024		5/16			
43006	100	3/8	43025		3/8			
43007	100	7/16	43026		7/16			
43008	100	1/2	43027		1/2			
43009	100	9/16	--	--	--			
43011	50	3/4	43045		3/4			
43010	50	5/8	43028		5/8			

Assortments  
Qual #: 43018  
3/16" thru 1/4" in a  
12 comp. labeled box.

Qual #: 43017  
3/16" thru 1/2" in a  
6 comp. labeled box

### HIGH ALLOY LOCK WASHERS

Yellow Dichromate Finish

Qual #	Size	Bx	Qual #	Size	Bx
43140	1/4	100	43147	3/4	50
43141	5/16	100	43148	7/8	25
43142	3/8	100	43149	1	25
43143	7/16	100	43150	1-1/8	10
43144	1/2	100	43151	1-1/4	10
43145	9/16	50	43152	1-1/2	10
43146	5/8	50			

- Precision Heat treated to eliminate Hydrogen Embrittlement
- Rockwell Hardness increased
- Manufactured from Alloy Steel
- Meets A.N.S.I. & SAE Spec.
- Required for use with Alloy Screws and Nuts.



**3 ADVANTAGES:** Hydrogen embrittlement eliminated. Thicker coating for greater corrosion resistance, and Rockwell hardness increased.

# Washers

## SHAKEPROOF WASHERS

Permaplate Finish

External	
Qual #	Dia.
43030	#6
43031	#8
43032	#10
43033	#12
43034	1/4
43035	5/16

Internal	
Qual #	Dia.
43060	#6
43061	#8
43062	#10
43063	#12
43064	1/4
43065	5/16
43066	3/8

Counter-sunk	
Qual #	Dia.
43091	#8
43092	#10
43093	#12
43094	1/4
43095	5/16
43096	3/8

**Assortment**  
Qual #: 43074



**Assortment**  
Qual #: 43044



**Assortment**  
Qual #: 43097



## RHINALLOY EXTRA THICK FLAT WASHERS

Thru Hardened For use with Grade 5 and Grade 8 Hex Cap Screws

Qual #	Size	Min.Thick	Bx
8640	1/4	.090	100
8641	5/16	.090	100
8642	3/8	.090	100
8643	7/16	.090	50
8644	1/2	.156	50
8645	9/16	.156	25
8646	5/8	.170	25
8647	3/4	.170	20
8648	7/8	.235	15
8649	1	.235	10

**ASSORTMENT** Qual #: 43099 Internal, External, Countersunk in 24 comp. labeled tray

## FENDER WASHERS

Zinc Plated, 50/box

Qual #	Bolt Size	Out. Dia.
43157	1/4	1-1/4
43158	5/16	1-1/2
43159	3/8	1-1/2
43160	3/16	1"
43161	3/16	1-1/4



## FINISHING WASHERS

Nickel Plated on Brass, 50/box

Counter-sunk		Flush		Flange Counter-sunk	
Qual #	Size	Qual #	Size	Qual #	Size
43165	#4	43171	#4	--	--
43166	#6	43172	#6	43175	#6
43167	#8	43173	#8	43176	#8
43168	#10	43174	#10	43177	#10
43169	#12				
43170	1/4				
43178	Assortment				

Qual #: 43179 Assortment



## COPPER WASHERS

Qual #	Bolt Size	I.D.	O.D.	Thickness
42914	3/16	1/4	5/8	1/16
42915	1/4	5/16	11/16	1/16
42913	5/16	3/8	9/16	1/32
42916	5/16	3/8	3/4	1/16
42917	3/8	7/16	13/16	1/16
42918	7/16	1/2	7/8	1/16
42919	1/2	9/16	13/16	3/32

## COTTER PINS

Plated SAE Approved Steel, Accurately Formed Heads

Qual #	DIA.	Lgth.	Qual #	DIA.	Lgth.	Qual #	DIA.	Lgth.	Qual #	DIA.	Lgth.
2740	1/16	1"	2745	3/32	3/4	--	--	--	2760	1/8	1"
2741	1/16	1-1/4	2746	3/32	1"	2752	7/64	1"	2761	1/8	1-1/4
2742	1/16	1-1/2	2747	3/32	1-1/4	2753	7/64	1-1/2	2762	1/8	1-1/2
2743	1/16	2"	2748	3/32	1-1/2	2754	7/64	2"	2763	1/8	1-3/4
--	--	--	2749	3/32	2"	--	--	--	2764	1/8	2"
--	--	--	2750	3/32	2-1/2	--	--	--	2765	1/8	2-1/2
--	--	--	--	--	--	--	--	--	2766	1/8	3"
2780	3/16	1"	2790	1/4	1-1/2	2800	5/16	2"	2810	3/8	2"
2781	3/16	1-1/2	2791	1/4	2"	2801	5/16	2-1/2	2811	3/8	3"
2782	3/16	2"	2792	1/4	2-1/2	2802	5/16	3"	2812	3/8	4"
2783	3/16	2-1/2	2793	1/4	3"	2803	5/16	4"	2813	3/8	5"
2784	3/16	3"	2794	1/4	3-1/2	2804	5/16	5"	2814	3/8	6"
2785	3/16	4"	2795	1/4	4"	2805	5/16	6"	--	--	--
--	--	--	2796	1/4	5"	--	--	--	--	--	--
--	--	--	2797	1/4	6"	--	--	--	--	--	--

Assortments: 10051, 33112, A-1021

Qual #: 2764-H 1/8X2 PLATED Hammer Lck Cotter

Qual #: 2741-H 1/16X1-1/4 PLAIN Hammer Lck Cotter



## Machine Screws

### PHILLIPS BINDING HEAD



Qual #	Size	Qual #	Size
45882	4-40 x 1/4	45776	10-24 x 3/8
45883	3/8	45777	1/2
45884	1/2	45894	5/8
45885	3/4	45778	3/4
45762	6-32 x 1/4	45779	1
45763	3/8	45780	1-1/4
45764	1/2	45781	1-1/2
45891	5/8	45784	10-32 x 3/8
45765	3/4	45785	1/2
45766	1	45786	3/4
45767	1-1/4	45787	1
45768	1-1/2	45788	1-1/4
45769	8-32 x 1/4	45789	1-1/2
45770	3/8	45792	1/4-20x 1/2
45771	1/2	45793	1/4
45892	5/8	45794	1
45772	3/4	45795	1-1/4
45773	1	45796	1-1/2
45893	1-1/4	45797	1-3/4
45774	1-1/2	45798	2
		45801	Assortment

**ALSO AVAILABLE:**

**PHILLIPS ROUND**

Qual #: 45802 thru 45849, Assortment Qual #: 45832

**PHILLIPS OVAL**

Qual #: 45295 thru 45365, Assortment Qual #: 45367

### SLOTTED ROUND HEAD



Qual #	Size	Qual #	Size	Qual #	Size	Qual #	Size
45560	4-40 x 1/4	45595	10-24 x 5/8	45618	12-24 x 1		
45561	3/8	45596	3/4	45619	1-1/4		
45562	1/2	45597	7/8	45620	1-1/2		
45563	5/8	45598	1	45622	2		
45564	3/4	45599	1-1/4	45624	1/4-20 x 1/2		
45566	1	45600	1-1/2	45625	3/4		
45569	6-32 x 1/4	45741	1-3/4	45626	1		
45570	3/8	45601	2	45627	1-1/4		
45571	1/2	45602	2-1/2	45628	1-1/2		
45572	5/8	45603	3	45629	2		
45573	3/4	45742	3-1/2	45631	2-1/2		
45575	1	45743	4	45632	3		
45576	1-1/4	45604	10-32 x 1/4	45749	3-1/2		
45577	1-1/2	45605	3/8	45750	4		
45580	8-32 x 1/4	45606	1/2	45753	5/16-18 3/4		
45581	3/8	45607	5/8	45754	1		
45582	1/2	45608	3/4	45756	1-1/2		
45583	5/8	45610	1	45757	2		
45584	3/4	45611	1-1/4	45758	2-1/2		
45586	1	45612	1-1/2	45759	3		
45587	1-1/4	45744	1-3/4	45630	Assortment		
45588	1-1/2	45613	2				
45589	2	45614	2-1/2				
45592	10-24 x 1/4	45615	3				
45593	3/8	45616	12-24 x 1/2				
45594	1/2	45617	3/4				

**ALSO AVAILABLE:**

**SLOTTED FLAT HEAD**

Qual #: 45368 thru 45480, Assortment Qual #: 45484

**SLOTTED OVAL HEAD**

Qual #: 45491 thru 45556, Assortment Qual #: 45558 (Special Order)

**SLOTTED TRUSS HEAD**

Qual #: 45633 thru 45683, Assortment Qual #: 45685 (Special Order)

### SELF THREADING MACHINE SCREW

Hex Washer Head, Thread Cutting, Type F

Qual #	Size	Qual #	Size
45200	6-32 x 1/4	45220	1/4-20 x 1/2
45201	1/2	45221	3/4
45202	3/4	45222	1
45203	1	45231	5/16-18 x 3/4
45207	8-32 x 1/2	45232	1
45213	10-24 x 1/2		
45214	3/4		
45215	1		



45217 Assortment 8-32 thru 10-24 in plastic box

Hex Washer Head, Thread Cutting, Type I (D)

Qual #	Size
45250	8-32x 1/2
45252	3/4
<i>45256</i>	10-32x 1/2
<i>45258</i>	3/4
45262	12-24x 3/4



SAE Thread shown in *ITALIC*  
Assortment 45263 All sizes shown, in plastic box

Hex Washer Head, Thread Cutting, Type F

Qual #	Size
45242	1/4-20x 1/2
45243	3/4
45244	1
45247	5/16-24x 1



Assortment 45248 All sizes shown, in plastic box

### 1/4" HEX DRIVE MAGNETIC NUT SETTERS-SHORT

Qual #	Size
2915	Hex Size 1/4"
2916	Hex Size 5/16"
2917	Hex Size 3/8"



### PHILLIPS INSERT BITS

Qual #	Point Size
2920	#1
2921	#2 x 1
2922	#2 x 1-15/16
2923	#2 x 6
2924	#2 x 3-1/2



### SQUARE RECESS POWER BIT 1/4 HEX

Qual #	Size
2925	2x1-15/16



# Sheet Metal Screws Permaplate Finish

## PHILLIPS OVAL HEAD

Qual #	Size	Qual #	Size
46121	6 x 3/8	46151	10 x 1-1/2
46122	1/2	46152	1-3/4
46123	5/8	46153	2
46124	3/4	46154	2-1/2
46126	1	46159	12 x 1/2
46127	1-1/4	46161	3/4
46131	8 x 3/8	46163	1
46132	1/2	46164	1-1/4
46133	5/8	46165	1-1/2
46134	3/4	46167	2
46136	1	46170	14 x 3/4
46137	1-1/4	46171	1
46138	1-1/2	46171A	1-1/4
46139	1-3/4	46171B	1-1/2
46140	2	46173	Assortment
46145	10 x 1/2		
46146	5/8		
46147	3/4		
46149	1		
46150	1-1/4		

Also Available:  
**PHILLIPS OVAL**  
 (Undersize)  
 Qual #: 46175 thru 46220  
 Available by request.



## SLOTTED BINDING HEAD

Qual #	Size	Qual #	Size	Qual #	Size
46304	4 x 1/4	46324	8 x 5/8	46347	12 x 5/8
46300	3/8	46325	3/4	46348	3/4
46301	1/2	46327	1	46350	1
46302	5/8	46328	1-1/4	46069	1-1/4
46303	3/4	46329	1-1/2	46351	1-1/2
46306	6 x 1/4	46330	1-3/4	46070	1-3/4
46307	3/8	46331	2	46352	2
46308	1/2	46333	2-1/2	46354	2-1/2
46309	5/8	46065	3	46072	3
46310	3/4	46334	10 x 3/8	46355	14 x 1/2
46312	1	46335	1/2	46356	5/8
46313	1-1/4	46336	5/8	46357	3/4
46314	1-1/2	46337	3/4	46359	1
46061	7 x 3/8	46339	1	46360	1-1/4
46316	1/2	46340	1-1/4	46361	1-1/2
46062	5/8	46341	1-1/2	46073	1-3/4
46317	3/4	46342	1-3/4	46362	2
46318	1	46343	2	46365	2-1/2
46321	8 x 1/4	46066	2-1/2	46367	3
46322	3/8	46068	3	46364	Assortment
46323	1/2	46346	12 x 1/2		



## PHILLIPS BINDING HEAD

Qual #	Size	Qual #	Size
2840	4 x 1/4	2870	10 x 1/2
2841	3/8	2871	5/8
2842	1/2	2872	3/4
2843	5/8	2873	1
2844	3/4	2874	1-1/4
2847	6 x 1/4	2875	1-1/2
2848	3/8	2876	2
2849	1/2	2880	12 x 1/2
2850	5/8	2881	5/8
2851	3/4	2882	3/4
2852	1	2883	1
2853	1-1/4	2884	1-1/4
2854	1-1/2	2885	1-1/2
2857	8 x 1/4	2886	2
2858	3/8	2890	14 x 1/2
2859	1/2	2891	5/8
2860	5/8	2892	3/4
2861	3/4	2893	1
2862	1	2894	1-1/4
2863	1-1/4	2895	1-1/2
2864	1-1/2	2896	1-3/4
2865	2	2897	2
2869	10 x 3/8	2898	2-1/4

Assortment A-1251 available



## SELF-DRILLING

- Drills up to 3/16" steel
- Cuts its own threads
- Hex washer head drill screws

Qual #	Size	Qual #	Size
46740	6 x 1/2	46760 **	12 x 3/4
46741	3/4	46764 **	1
46742	1	46762	1-1/4
46755 ***	8 x 1/2	46763	1-1/2
46756 ***	3/4	46765	2
46766 **	1	46778 **	1/4 x 3/4
46749	1-1/4	46779 **	1
46749A	1-1/2	46750	1-1/4
46757 **	10 x 1/2	46751	1-1/2
46758 ***	3/4	46752	2
46759 **	1	46753	2-1/2
46767	1-1/4	46754	3
46768	1-1/2	46761	Assortment
46768A	2		

\*\* avail 100 in box (-1)

\*\*\* avail in both 1000 (-M) & 100 (-1) / bx

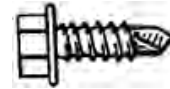

## POSIDRIVE HEAD DRILL SCREWS

Qual #	Size
46880	6 x 1/2
46881	3/4
46882	1
46770 *	8 x 1/2
46771 *	3/4
46772 *	1
46772A	1-1/4
46772B	1-1/2
46773 *	10 x 1/2
46774 *	3/4
46769 *	1
46776 *	1-1/4
46777 *	1-1/2
46775 *	12 x 1

\* avail 100 in box (-1)



## Sheet Metal Screws Permaplate Finish

### HEX HEAD

Qual #	Size	Qual #	Size	Qual #	Size
2980	8 x 3/8	2995	12 x 1/2	3009	14x 1-1/2
2981	1/2	2997	3/4	3010	2
2982	5/8	2998	1	3014	5/16x 3/4
2983	3/4	2999	1-1/4	3015	1
2984	1	3000	1-1/2	3016	1-1/4
2987	10 x 1/2	3001	2	3017	1-1/2
2988	5/8	3004	14 x 1/2	3018	2
2989	3/4	3005	5/8	3020	3/8 x 3/4
2990	1	3006	3/4	3021	1
2991	10 x 1-1/4	3007	1	3022	1-1/4
2992	1-1/2	3008	14 x 1-1/4	3023	1-1/2
				3024	1-3/4



### HEX HEAD SLOTTED

Qual #: 46620 thru 46649  
Available by Request



### HEX HEAD WITH LOOSER WASHER

Qual #: 2961 thru 2970  
Available by Request



### SLOTTED HEX WASHER HEAD

Qual #	Size	Qual #	Size
46689	6 x 3/8	46705	10 x 3/4
46690	1/2	46707	1
46691	5/8	46708	1-1/4
46692	3/4	46709	1-1/2
46693	7/8	46710	12 x 1/2
46694	1	46711	5/8
46697	8 x 3/8	46712	3/4
46612	1/2	46714	1
46698	5/8	46715	2
46613	3/4	46717	14 x 1/2
46699	7/8	46718	5/8
46700	1	46719	3/4
46701	1-1/4	46720	1
46614	1-1/2	46721	1-1/4
46702	10 x 3/8	46723	1-1/2
46703	1/2	46725	2
46704	5/8		



### UNSLOTTED HEX WASHER HEAD

Qual #	Size	Head Size	Qual #	Size	Head Size
2930	10 x 1/2	5/16	2945	14 x 3/4	7/16
2931	5/8	5/16	2946	3/4	3/8
2935	12 x 1/2	5/16	2947	1	7/16
2936	5/8	5/16	2948	1-1/4	7/16
2937	3/4	5/16	2949	1-1/2	7/16
2938	1	5/16	2952	5/16 x 5/8	7/16
2939	1-1/4	5/16	2953	3/4	7/16
2940	1-1/2	5/16	2954	1	7/16
2942	14 x 1/2	3/8	2955	1-1/4	7/16
2943	5/8	3/8	2956	1-1/2	7/16
2944	5/8	7/16			

Assortment 45936 19 popular sizes in metal tray



### SLOTTED OVAL HEAD

Qual #: 46230 thru 46293 Sizes  
4x1/2 thru 14x3/4  
Assortment 46299 - By Request

### SLOTTED FLAT HEAD

Qual #: 46466 thru 46499 Sizes  
6x3/8 thru 14x2  
Assortment 46501 - By Request

### SLOTTED TRUSS HEAD

Qual #: 46433 thru 46457 Sizes  
6x3/8 thru 14x1 - By Request

## Specialty Screws

### TORX HEAD TYPE "F" FLOOR BOARD SCREWS



Qual #	Size	Qual #	Size
3031	1/4 x 1-1/2	3036	3-1/2
3032	2	3039	5/16 x 2
3033	2-1/4	3040	2-1/4
3034	2-1/2	3041	5/16 x 2-1/2
3035	3		

### METRIC TORX

#### Stainless Steel Torx Head Oval

Qual #	Size	Finish
38937	4.2 x 20 MM	Chrome
38938	4.2 x 20 MM	Blk Oxide
41053	4.2 x 25 MM	Blk Oxide
38939	4.2 x 30 MM	Chrome
38940	4.2 x 30 MM	Blk Oxide
41047	4.2 x 35 MM	Blk Oxide
38941	4.2 x 40 MM	Chrome
38942	4.2 x 55 MM	Chrome

\* Pan Sems (Attached Washer)



#### Stainless Steel Torx Pan Head

Qual #	Size	Finish
41052	4.2 X 16 MM	Blk Oxide
38943	4.2 X 20 MM	Chrome
38944	4.2 X 20 MM	Blk Oxide
41048	4.2 X 20 MM*	Blk Oxide
41051	4.2 X 20 MM*	Blk Oxide
41049	4.2 X 25 MM	Chrome
41050	4.2 X 30 MM	Blk Oxide
38945	4.2 X 35 MM	Chrome
41046	4.2 X 35 MM	Blk Oxide
38946	4.2 X 50 MM	Blk Oxide

### THUNDERPOINT DRYWALL SCREWS

Phillips bugle head, black phosphate finished and hardened. Fastest method for attaching gypsum board to light gauge metal framing or wood.



Qual #	Size
2905	6 x 1
2906	1-1/8
2907	1-1/4
2908	1-5/8
2909	2
2910	2-1/4
2911	8 x 2-1/2
2912	3

### PHILLIPS HEAD TYPE "F" FLOOR BOARD SCREW

Qual #	Size
3045	1/4x 1-1/2
3046	2-1/2



### TORX INSERT BITS FOR TORX SCREWS

Qual #	Size	Screw Size	Qual #	Size	Screw Size
3055	T-15	6	3058	T-30	1/4
3056	T-20	8	3059	T-40	5/16
3057	T-25	10			





## SOCKET HEAD CAP SCREWS - ALLOY STEEL

Lgth	4-40	5-40	6-32	8-32	10-24	10-32	1/4	5/16	3/8	7/16	1/2	5/8	3/4	7/8	1"			
1/4 USS SAE	50060	50065	50070															
3/8 USS SAE	50061	50066	50071	50077	50083	50283	50095	50107A										
1/2 USS SAE	50062	50067	50072	50078	50084	50284	50096	50108	50120									
5/8 USS SAE	50063	50068	50073	50079	50085	50285	50097	50109	50121									
3/4 USS SAE	50064	50069	50074	50080	50086	50286	50098	50110	50122	50139	50155							
7/8 USS SAE			50075	50081	50087	50287	50099	50111	50123	50140	50156							
1" USS SAE			50076	50082	50088	50288	50100	50112	50124	50141	50157	50175						
1-1/4 USS SAE					50089	50289	50101	50113	50125	50142	50158	50176						
1-1/2 USS SAE					50090		50102	50114	50126	50143	50159	50177	50193					
1-3/4 USS SAE						50290	50103	50115	50127	50144	50160	50178	50194					
2" USS SAE					50091		50104	50116	50128	50145	50161	50179	50195	50210				
2-1/4 USS SAE							50304	50316	50328	50345	50361	50379						
2-1/2 USS SAE							50105		50129	50146	50162	50180	50196	50211	50225			
2-3/4 USS SAE									50329		50362							
3" USS SAE							50106	50117	50130	50147	50163	50181	50197	50212	50226			
3-1/4 USS SAE								50317	50330		50363	50381						
3-1/2 USS SAE								50118	50131		50164	50182	50198	50213	50227			
4" USS SAE							50107	50119	50132	50149	50165	50183	50199	50214	50228			
4-1/2 USS SAE									50332		50365							
5" USS SAE										50133	50166	50185	50200	50215	50229			
5-1/2 USS SAE										50134	50167	50186	50201	50216	50230			
6" USS SAE											50168	50187	50202	50217	50231			
											50136	50169	50188	50203	50218	50232		
												50189	50204	50219	50233			
													50138	50171	50190	50205	50220	50234

50235 & 50236  
(USS) Assortments

**USS  
(Coarse) Thread**

**SAE  
(Fine) Thread**

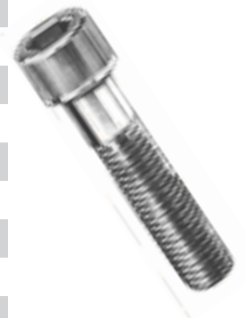

## FLAT HEAD

Lgth	6-32	8-32	10-24	10-32	1/4	5/16	3/8	7/16	1/2	5/8	3/4	
1/4 USS SAE	50390											
3/8 USS SAE	50391	50396	50405	50412	50418	50618						
1/2 USS SAE	50392	50397	50406	50413	50419	50430						
5/8 USS SAE	50393	50398	50407	50414	50420	50431	50441					
3/4 USS SAE	50394	50399	50408	50415	50421	50432	50442	50451	50460			
1" USS SAE		50400	50409	50416	50422	50433	50443	50452	50461			
1-1/4 USS SAE			50410		50423	50434	50444	50453	50462	50470		
1-1/2 USS SAE					50424	50435	50445	50454	50463	50471	50478	
1-3/4 USS SAE					50624	50635	50645		50663			
2" USS SAE						50436	50446		50464	50472		
2-1/4 USS SAE						50426	50437	50447	50456	50465	50473	50479
2-1/2 USS SAE							50438	50448		50665	50474	
3" USS SAE								50439	50449	50467	50475	50480
3-1/2 USS SAE									50450	50468	50476	50481
										50450A	50469	



Asst Qual #: 50482  
USS Thread

## BUTTON HEAD

Lgth under head	#4	#6	#8	#10	1/4	5/16	3/8	#4	#6	#8	#10	1/4	5/16	3/8	
1/4 USS SAE	50490	50493						KEY >>	40 TPI	32 TPI	32 TPI	24 TPI	20 TPI	18 TPI	16 TPI
3/8 USS SAE	50491	50494	50497	50501					1/16	5/64	3/32	1/8	3/16	3/16	7/32
1/2 USS SAE	50492	50495	50498	50502	50506	50510	50514								
5/8 USS SAE		50496	50499	50503	50507	50511	50515								
3/4 USS SAE				50500	50504	50508	50512	50516							
1" USS SAE					50505	50509	50513	50517							
1-1/4 USS SAE						50270		50518							

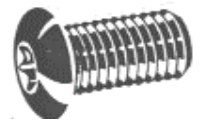

## Bolts (Stove, Rock Crusher Screen, Heated Treated Plow)

### STOVE BOLTS - ROUND HEAD SUPPLIED WITH HEX NUTS

USS Thread, Plated, SAE Approved Steel, Clean Sharp Finished Threads, Fully Formed, Deep Slotted Head

Qual #	Lgth	Pkg	Qual #	Lgth	Pkg	Qual #	Lgth	Pkg	Qual #	Lgth	Pkg
<b>Dia. 3/16</b>			<b>Dia. 1/4</b>			<b>Dia. 5/16</b>			<b>Dia. 3/8</b>		
2620	1/2	100	2635	1/2	100	2648	1/2	50	2660	1	50
2621	3/4	100	2636	3/4	100	2649	3/4	50	2661	1-1/2	50
2622	1	100	2637	1	100	2650	1	50	2662	2	50
2623	1-1/4	100	2638	1-1/4	100	2651	1-1/4	50	2663	2-1/2	50
2624	1-1/2	100	2639	1-1/2	100	2652	1-1/2	50	2664	3	50
2625	1-3/4	100	2640	1-3/4	100	2653	2	50	2666	4	50
2626	2	100	2641	2	100	2654	2-1/2	50	Asst. Qual #: A-1218 available		
2627	2-1/4	100	2642	2-1/2	100	2655	3	50			
2628	2-1/2	100	2643	3	50	2657	4	50			
2629	3	50	2644	3-1/2	50						
2630	3-1/2	50	2645	4	50						
2631	4	50									

### STOVE BOLTS - FLAT HEAD SUPPLIED WITH HEX NUTS

USS Thread, Plated, SAE Approved Steel, Clean Sharp Finished Threads, Fully Formed, Deep Slotted Head

Qual #	Lgth	Pkg	Qual #	Lgth	Pkg	Qual #	Lgth	Pkg	Qual #	Lgth	Pkg
<b>Dia. 3/16</b>			<b>Dia. 1/4</b>			<b>Dia. 5/16</b>			<b>Dia. 3/8</b>		
2670	1/2	100	2684	1/2	100	2697	1/2	50	2709	1	50
2671	3/4	100	2685	3/4	100	2698	3/4	50	2710	1-1/2	50
2672	1	100	2686	1	100	2699	1	50	2711	2	50
2673	1-1/4	100	2687	1-1/4	100	2700	1-1/4	50	2712	2-1/2	50
2674	1-1/2	100	2688	1-1/2	100	2701	1-1/2	50	2713	3	50
2675	1-3/4	100	2689	1-3/4	100	2702	2	50	2715	4	50
2676	2	100	2690	2	100	2703	2-1/2	50			
2677	2-1/4	100	2691	2-1/2	100	2704	3	50			
2678	2-1/2	100	2692	3	50	2706	4	50			
2679	3	50	2693	3-1/2	50						
2680	3-1/2	50	2694	4	50						
2681	4	50									

### HEAT TREATED PLOW BOLTS #3 Grade 8 Dome Head

Qual #	Lgth	Pkg	Qual #	Lgth	Pkg	Qual #	Lgth	Pkg	Qual #	Lgth	Pkg
<b>Dia. 5/8-11</b>			<b>Dia. 3/4-10</b>			<b>Dia. 7/8-9</b>			<b>Dia. 1"-8</b>		
1328	2	20	1340	2	15	1350	2-1/2	10	1358	2-1/2	10
1329	2-1/4	20	1341	2-1/4	15	1351	3	10	1359	3	10
1330	2-1/2	20	1342	2-1/2	10	1352	3-1/2	10	1360	3-1/2	10
1331	2-3/4	20	1343	2-3/4	10	1353	4	10	1361	4	10
1332	3	15	1344	3	10	1354	5	10	1362	4-1/2	10
1333	3-1/2	10	1345	3-1/2	10				1363	5	10
1334	4	10	1346	4	10				1364	5-1/2	10
1335	4-1/2	10	1347	5	10				1365	6	10

### HEAT TREATED PLOW BOLTS #3 Grade 5 Flat Head

Qual #	Lgth	Pkg	Qual #	Lgth	Pkg	Qual #	Lgth	Pkg
<b>Dia. 3/8-16</b>			<b>Dia 7/16-14</b>			<b>Dia. 1/2-13</b>		
1300	1	50	1307	1-1/4	25	1318	1-1/2	20
1301	1-1/4	50	1308	1-1/2	25	1319	1-3/4	20
1302	1-1/2	50	1309	1-3/4	25	1320	2	20
1303	2	25	1310	2	25	1321	2-1/4	20
1304	2-1/2	25	1311	2-1/4	25	1322	2-1/2	20
			1312	2-1/2	25	1323	3	20
			1313	2-3/4	20	1324	3-1/2	20
			1314	3	20			

### ROCK CRUSHER SCREEN BOLTS

Grade 5, Double Heat Treated USS Thread (Nuts not included)

Qual #	Size	Pkg
1370*	3/8 x 2	25
1371*	3	15
1372*	4	
1375	1/2 x 3	
1376	4	
1377	5	10
1380	5/8 x 4	
1381	5	
1382	6	
1385	3/4 x 4	
1386	5	
1387	6	



\* Avail Full Thread by special request. All other sizes are full thread.

We recommend the use of either **Elastic Stop Nut** or **Stover Locknut** for all Screen Bolts



Stop Nut

Stover

# Special Bolts

## COUNTER-BOR BOLTS

L-9 Alloy Steel, USS Plated



Qual #	Size	Pkg	Qual #	Size	Pkg	Qual #	Size	Pkg
2180	1/4x 3/4	25	2203	3/8x 1-1/2	20	2225	1/2x 3-1/2	5
2181	1	25	2204	2	15	2226	4	5
2182	1-1/4	25	2205	2-1/2	10	2230	5/8x 1-1/2	5
2183	1-1/2	25	2206	3	10	2231	2	5
2184	2	20	2210	7/16x 3/4	10	2232	2-1/2	5
2190	5/16x 3/4	25	2211	1	10	2233	3	5
2191	1	25	2212	1-1/2	10	2234	3-1/2	5
2192	1-1/4	25	2213	2	10	2235	4	5
2193	1-1/2	20	2214	2-1/2	5	2240	3/4x 1-1/2	5
2194	2	20	2215	3	5	2241	2	5
2195	2-1/2	15	2220	1/2x 1	10	2242	2-1/2	5
2196	3	10	2221	1-1/2	10	2243	3	5
2200	3/8x 3/4	25	2222	2	5	2244	3-1/2	5
2201	1	20	2223	2-1/2	5	2245	4	5
2202	1-1/4	20	2224	3	5			

## SQUARE HEAD BOLTS

Grade 8

Qual #	Size
1850	1/2 3x1-3/4
1851	13x2
1852	13x3
1865	1-1/4 7x12
1890	7x10



## SN-100

1/4-20 Square Nut, Bx / 100



## HEX FLANGE LOCK NUTS

Grade 8.2, Alloy, USS Plated

Qual #	Size	Pkg
2270	1/2	25
2271	5/8	25



# Metric Facts & Conversion

METRIC Actual Size	Diameter in MM	American Exact Size Fractional	American Approx. Size In Inches
	2.6	.1024	7/64
	3	.1181	1/8
	4	.1575	5/32
	5	.1968	3/16
	6	.2362	15/64
	7	.2756	17/64
	8	.3149	5/16
	10	.3937	3/8
	12	.4720	15/32
	14	.5512	35/64

## STEP BOLTS

Hex Nuts not included

Qual #	Size	Pkg
1440	1/4x 1	25
1441	1-1/2	25
1442	2	25
1445	5/16x 1	25
1446	1-1/2	25
1447	2	25
1450	3/8x 1	25
1451	1-1/2	25
1452	2	20
1453	3	15



## ELEVATOR BOLTS

Hex Nuts not included, Pkg 25

Qual #	Size	Pkg
1425	1/4x 1	25
1426	1-1/2	25
1427	2	25
1430	5/16x 1	25
1431	1-1/2	25
1432	2	25
1433	2-1/2	25
1435	3/8x 1	25
1436	1-1/2	25
1437	2	25
1438	2-1/2	25



## GRADE 8 HEAT TREATED

#7 Head Bucket Tooth Screws

Qual #	Size	Pkg
1395	5/8x 1-1/2	10
1396	4	10
1400	3/4x 2-1/2	6
1401	4-1/2	6
1402	6	6
1403	3	6
1405	7/8x 4-1/2	6
1406	6	6
1410	1x 4	5
1411	6	5
1412	8	5
1415	1-1/8x 6	1
1416	1-1/4x 6	1
1417	8	1



## HEX FLANGE BOLTS

Grade 8.2, Alloy, USS Plated

Qual #	Size	Pkg
2250	1/2x 1-1/2	25
2251	1-3/4	25
2252	2	15
2253	2-1/4	15
2254	2-1/2	15
2255	3	15
2256	3-1/2	15
2257	4	10
2260	5/8x 1-1/2	10
2261	1-3/4	10
2262	2	10
2263	2-1/2	10
2264	3	10
2265	3-1/2	10
2266	4	10



## METRIC Actual Length Length In MM

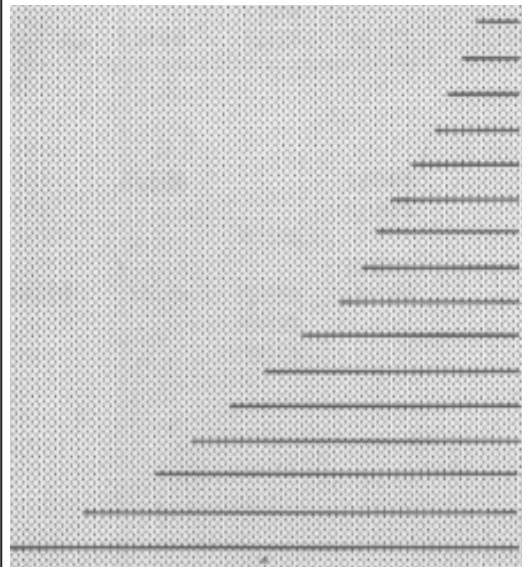

## American Approx. Length In Inches

6MM	15/64
8MM	5/16
10MM	3/8
12MM	15/32
16MM	5/8
18MM	11/16
20MM	25/32
22MM	7/8
25MM	1"
30MM	1-3/16
35MM	1-3/8
40MM	1-9/16
45MM	1-3/4
50MM	2"
60MM	2-3/8
70MM	2-3/4

## Cap Screws

### COURSE METRIC CAP SCREWS

(MM) Diameter and THREAD PITCH (decimal no.)

#### DIN 933 (Thread to Head)

Lgth MM	4mm .70	5mm .80	6mm 1.00	7mm 1.00	8mm 1.25	10mm 1.50	12mm 1.75	14mm 2.00	16mm 2.00	18mm 2.50	20mm 2.50	22mm 2.50
6	49705											
10	49706	49720	49735	49760								
12	49707	49721	49736	49761	49780	49800						
16	49708	49722	49737	49762	49781	49801						
20	49710	49724	49739	49764	49783	49803	49825	49840	49865			
25	49712	49726	49741	49765	49785	49805	49826	49845	49866			
30	49713	49727	49742	49766	49786	49806	49827	49846	49867			
35	49714	49728	49743	49767	49787	49807	49828	49847	49868			
40	49715	49729	49744	49768	49788	49808	49829	49848	49869		49900	
45			49745		49789	49809	49830	49849				
50			49746	49769	49790	49810		49850	49870	49880	49890	49901
55			49747		49791							
60			49748			49811	49832	49851	49871			49902
65												
70			49749			49812	49833		49872		49885	49903
75												
80						49813	49834		49873			49904
90						49814						
100												

#### Din 931 (Thread Lgth = 2xDia. + 6MM)

Lgth MM	4mm .70	5mm .80	6mm 1.00	7mm 1.00	8mm 1.25	10mm 1.50	12mm 1.75	14mm 2.00	16mm 2.00	18mm 2.50	20mm 2.50	22mm 2.50
40		49730										
45		49731	49750									
50			49751				49831	49854				
60		49732	49752	49770	49792	49815	49835		49876	49881	49891	
70		49733	49753		49795	49816	49836	49855		49882	49892	
75					49794		49837	49852	49877			
80					49796		49838	49856		49883	49893	
90							49839	49853	49874	49884	49894	49905
100								49857			49895	49906
110							49817					

#### Hex Nut & Cap Screw Head Actual Sizes



5MM



6MM



7MM



8MM



10MM



12MM

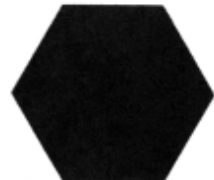

14MM

# Cap Screws

## FINE METRIC CAP SCREWS

The Lower the Pitch Number - The Finer the Thread

### Din 961 (Thread to Head)

Lgth MM	8mm 1.0	10mm 1.25	10mm 1.0 VF	12mm 1.50	12mm 1.25VF	14mm 1.50	16mm 1.50
16	49910	49920					
18							
20	49911	49921	49935				
22							
25	49913	49922	49936	49949	49960		
30	49914	49923		49950	49961		
35	49915	49924	49937	49951	49962		49981
40	49916	49925	49938	49952	49963	49975	
45	49917				49964		
50	49918	49926	49939	49953	49965	49976	49983
55							
60						49977	49984

### Din 960 (Thread Lgth + 2x Dia. + 6mm)

Lgth MM	8mm 1.0	10mm 1.25	10mm 1.0 VF	12mm 1.50	12mm 1.25VF	14mm 1.50	16mm 1.50
50							
60		49929	49941	49955	49967	49978	49985
65					49968		
70			49942	49956	49969	49979	49986
75		49930			49970		
80			49943		49971		
90		49931		49957		49980	49987

### METRIC HEX CAP SCREW ASSORTMENT (COURSE)

Qual #: 49119

Cap Screws, Nuts, Flat & Lock Washers packed in an 18 Drawer Cabinet with labeled drawers

6x 1.00 x12	8x 1.25 x16	10x 1.50 x20	<b>Hex Nuts</b>	
6x 1.00 x16	8x 1.25 x20	10x 1.50 x25	6x 1.00	
6x 1.00 x20	8x 1.25 x25	10x 1.50 x30	8x 1.25	
6x 1.00 x30	8x 1.25 x30	10x 1.50 x40	10x 1.50	
6x 1.00 x35	8x 1.25 x35	10x 1.50 x50	12x 1.75	
			14x 2.00	
			16x 2.00	
12x 1.75 x25	14x 2.00 x40	16x 2.00 x50	<b>Lock Washer</b>	<b>Flat Washer</b>
12x 1.75 x30	14x 2.00 x50	16x 2.00 x60	6	6
12x 1.75 x35	14x 2.00 x60	16x 2.00 x70	8	8
12x 1.75 x40	14x 2.00 x70		10	10
12x 1.75 x50			12	12
12x 1.75 x60			14	14
			16	16

### METRIC 10.9 HEX HEAD CAP SCREW (COURSE)

Qual #: 49118

Cap Screws, Nuts, Lock Washers packed in an 18 Drawer Cabinet with labeled drawers

6x 1.00 x16	8x 1.25 x16	10x 1.50 x20	<b>Hex Nuts</b>	
6x 1.00 x20	8x 1.25 x20	10x 1.50 x25	6x 1.00	
6x 1.00 x25	8x 1.25 x25	10x 1.50 x30	8x 1.25	
6x 1.00 x30	8x 1.25 x30	10x 1.50 x40	10x 1.50	
6x 1.00 x35	8x 1.25 x35	10x 1.50 x50	12x 1.75	
			14x 2.00	
			16x 2.00	
12x 1.75 x25	14x 2.00 x40	16x 2.00 x50	<b>Lock Washer</b>	<b>Flat Washer</b>
12x 1.75 x30	14x 2.00 x50	16x 2.00 x60	6	6
12x 1.75 x35	14x 2.00 x60	16x 2.00 x70	8	8
12x 1.75 x40	14x 2.00 x70		10	10
12x 1.75 x50			12	12
12x 1.75 x60			14	14
			16	16

## METRIC CAP SCREWS

### 10.9 ALLOY STEEL

6 x 1.00	Lgth	Pkg
48500	*16mm	25
48501	*20mm	25
48502	*25mm	25
48503	*30mm	25
48504	*35mm	25
48505	40mm	25
48506	*45mm	25
48507	50mm	25
48508	*60mm	25

8 x 1.25	Lgth	Pkg
48510	*16mm	25
48511	*20mm	25
48512	*25mm	25
48513	*30mm	25
48514	*35mm	25
48515	40mm	25
48516	45mm	25
48517	*50mm	25
48518	*60mm	25
48519	*70mm	25
48520	*80mm	15

10 x 1.50	Lgth	Pkg
48530	16mm	25
48531	*20mm	25
48532	*25mm	25
48533	*30mm	25
48534	35mm	25
48535	*40mm	25
48536	45mm	25
48537	*50mm	25
48538	60mm	20
48539	*70mm	
48540	*80mm	15
48541	90mm	
48542	*100mm	10

12 x 1.75	Lgth	Pkg
48550	*25mm	20
48551	*30mm	20
48552	*35mm	20
48553	*40mm	15
48554	*50mm	15
48555	*60mm	10
48556	70mm	10
48557	*80mm	10
48558	90mm	10
48559	*100mm	10
48560	110mm	5
48561	*120mm	5
48562	150mm	5
48563	160mm	5

14 x 2.0	Lgth	Pkg
48564	*40mm	5
48565	*50mm	5
48566	*60mm	5
48567	*70mm	5
48568	80mm	5
48569	90mm	5
48570	100mm	2
48571	110mm	2

16 x 2.0	Lgth	Pkg
48580	30mm	5
48581	40mm	5
48582	*50mm	5
48583	*60mm	5
48584	*70mm	5
48585	80mm	5
48586	*90mm	5
48587	100mm	5
48588	*110mm	5
48589	120mm	5
48590	130mm	5

16 x 2.0	Lgth	Pkg
48591	*140mm	5
48592	150mm	2
48593	160mm	2
48594	170mm	2
48595	*180mm	2
48596	190mm	2
48597	200mm	1
48598	*210mm	1
48599	220mm	1
48600	230mm	1
48601	240mm	1
48602	250mm	1

20 x 2.50	Lgth	Pkg
48612	40mm	5
48613	50mm	5
48614	60mm	5
48615	*70mm	5
48616	80mm	5
48617	90mm	5
48618	*100mm	5
48619	110mm	2
48620	120mm	2
48621	*130mm	2
48622	140mm	2
48623	150mm	1
48624	160mm	1
48625	170mm	1
48626	180mm	1
48627	*190mm	1
48628	200mm	1
48629	210mm	1
48630	220mm	1
48640	230mm	1
48641	240mm	1
48642	250mm	1

24 x 3.0	Lgth	Pkg
48660	40mm	2
48661	50mm	2
48662	60mm	2
48663	70mm	2
48664	80mm	1
48665	90mm	1
48666	100mm	1
48667	110mm	1
48668	120mm	1
48669	130mm	1
48670	140mm	1
48671	150mm	1
48672	160mm	1
48673	170mm	1
48674	180mm	1
48675	190mm	1
48676	200mm	1
48677	210mm	1
48678	220mm	1
48679	230mm	1
48680	240mm	1
48681	250mm	1

• **Stock Items**  
 All others Special Order

### 10.9 ALLOY STEEL HEX NUTS DIN 934



Qual #	Bolt Size	Thread Size
48690	6	1.00
48691	8	1.25
48692	10	1.50
48693	12	1.75
48694	14	2.00
48695	16	2.00
48696	20	2.50
48698	24	2.50



# METRIC NUTS

## METRIC HEX NUTS 8.8 DIN 934

Assortment Qual #: 49236 Available

Qual #	Bolt Size	Coarse	Thread Fine	Pitch Very Fine
49225	5	0.8		
49226	6	1.0		
49229	7	1.0		
49230	8		1.0	
49227	8	1.25		
49231	10			1.0
49237	10		1.25	
49228	10	1.5		
49238	12			1.25
49233	12		1.5	
49232	12	1.75		
49235	14		1.5	
49234	14	2.0		
49239	16		1.5	
49240	16	2.0		
49241	18	2.5		
49242	20	2.5		
49243	22	2.5		
49244	24	3.0		



## METRIC ELASTIC STOP NUTS 8.8 DIN 985

Assortment Qual #: 49310 Available

Qual #	Bolt Size	Coarse	Thread Fine	Pitch Very Fine
49306	5	0.8		
49300	6	1.0		
49307	8		1.0	
49302	8	1.25		
49308	10			1.0
49303	10	1.5		
49311	10		1.25	
49309	12		1.5	
49304	12	1.75		
49305	14	2.0		
49312	16	2.0		
49313	18	2.5		
49314	20	2.5		
49315	22	2.5		



## METRIC MACHINE SCREW NUTS 8.8 DIN 439

Assortment Qual #: 49219 Available

Qual #	Bolt Size	Thread Pitch
49221	3.0	0.50
49222	4	0.70
49223	5	0.80
49224	6	1.0



## LOCK WASHERS 10.9 ALLOY STEEL DIN 127

Qual #	Bolt Size
48710	6
48711	8
48712	10
48713	12
48714	14
48715	16
48716	20
48718	24



## FLAT WASHERS 10.9 DIN 125

Qual #	Bolt Size
48700	6
48701	8
48702	10
48703	12
48704	14
48705	16
48706	20
48708	24



## METRIC C/S & HEX NUT (COARSE & FINE) THREAD ASSORTMENT

Qual #: 49078

5x 0.8mm Hex Nut	8x 1.25mm Hex Nut
5x 12mm C/S	8x 12mm C/S
5x 20mm C/S	8x 15mm C/S
5x 25mm C/S	8x 20mm C/S
5x 30mm C/S	8x 25mm C/S
5x 35mm C/S	8x 30mm C/S
6x 1.0mm Hex Nut	8x 35mm C/S
6x 12mm C/S	10x 1.5mm Hex Nut
6x 25mm C/S	10x 15mm C/S
6x 30mm C/S	10x 20mm C/S
6x 35mm C/S	10x 25mm C/S
6x 40mm C/S	10x 30mm C/S

## METRIC CAP SCREW ASSORTMENT

Qual #: 49382 (coarse)

Thread with Flat & Lock Washer & Hex Nut

## METRIC HEX C/S ASSORTMENT

Qual #: 49079 (coarse)

Thread with Lock Washer & Hex Nut

## METRIC CAP SCREW ASSORTMENT

Qual #: 49384 (coarse & fine)

Thread with Flat & Lock Washer

## METRIC HEX C/S ASSORTMENT

Qual #: 49120 (fine)

Thread with Flat & Lock Washer & Hex Nut

## METRIC CAP SCREW ASSORTMENT

Qual #: 49112 (fine)

Thread with Hex Nut

## Metric

### LOCK WASHER DIN 127

Qual #	Screw Size
49258	M3
49259	M4
49260	M5
49261	M6
49262	M7
49263	M8
49264	M10
49265	M12
49266	M14
49268	M16
49279	M18
49280	M20
49281	M22

Asst 49267



### FLAT WASHER DIN 125

Qual #	Screw Size
49192	3
49193	4
49194	5
49195	6
49196	7
49197	8
49198	10
49199	12
49201	14
49202	16
49288	18
49289	20
49290	22

Asst 49200



### SPRING WASHER DIN 137

Qual #	Screw Size
49082	4
49083	5
49084	6
49085	7
49086	8
49087	10
49088	12
49089	14
49291	16
49090	Asst
49091	Asst

Contains Spring & Star Lock Washers



### JAM NUTS DIN 439



Qual #	Bolt Size	Coarse
49246	5	0.8
49247	6	1.0
49249	8	1.25
49251	10	1.5
49253	12	1.75

Asst . 49255 avail

### WING NUTS DIN 315



Qual #	Bolt Size	Coarse
49450	3	0.50
49451	4	0.70
49452	5	0.80
49453	6	1.0
49454	8	1.25

Asst. 49457 avail

### STAR WASHERS

#### External DIN 6797A



Qual #	Screw Size
49460	M2.6
49461	3
49462	4
49463	5
49464	6

#### Internal DIN 6797J



Qual #	Screw Size
49465	M2.6
49466	3
49467	4
49468	5
49469	6

#### Countersunk DIN 6797V



Qual #	Screw Size
49471	3
49472	4
49473	5
49474	6

### COTTER PINS

Qual #	Size
49356	2x18 MM
49357	2x22
49358	3x25
49359	4x30
49360	5x45
49361	5x60
49364	Asst

### LOCK WASHER HI COLLAR DIN 7980

For use on Socket Head C/S

Qual #	Screw Size
49270	M6
49271	8
49272	10

### METRIC SET SCREW-CUP POINT BLACK OXIDE FINISH DIN 916

#### 4 MM Diameter 0.7 Thread Pitch

Qual #	Lgth
49496	4MM
49497	6
49498	8
49499	10
49500	12
49501	16
49502	20

#### 5 MM Diameter 0.8 Thread Pitch

Qual #	Lgth
49504	6MM
49505	8
49506	10
49507	12
49508	16
49509	20

#### 6 MM Diameter 1.0 Thread Pitch

Qual #	Lgth
49512	8MM
49513	10
49514	12
49511	14
49515	16
49516	20

#### 8 MM Diameter 1.25 Thread Pitch

Qual #	Lgth
49517	8MM
49518	10
49519	12
49520	14
49521	16
49522	20



### ASSORTMENT

Qual #: 49525  
Contains all M5, 6 & 8 Sizes listed

### ASSORTMENT

Qual #: 49524  
Contains all M3 & M4 Sizes listed

# Metric

## METRIC STUDS DIN 939

Heavy Treated, Black Oxide Finish

Qual # Metric Lgth Overall Lgth

### 6 MM Diameter 1.0 Thread Pitch

49411	25MM	32.5MM
49412	30	37.5
49413	35	42.5
49414	40	47.5
49415	50	57.5

### 8MM Diameter 1.25 Thread Pitch

49417	20MM	30MM
49418	25	35
49419	30	40
49420	40	50
49421	45	55
49422	50	60
49423	55	65
49424	60	70
49425	65	75
49426	70	80

### 10MM Diameter 1.50 Thread Pitch

49428	30 MM	42MM
49429	40	52
49430	45	57
49431	50	62
49432	60	72
49433	70	82
49434	80	92

49410 & A-1234 Asst. avail

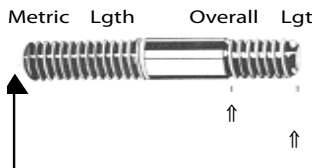

## SOCKET HEAD CAP SCREWS

Black Finish, DIN 912

Qual # Lgth

### 4MM Dia. 0.70 Pitch

49092	10MM
49093	16
49094	20

### 5MM Dia. 0.80 Pitch

49097	10MM
49098	16
49099	20
49100	30

### 6MM Dia. 1.0 Pitch

49160	8MM
49150	10
49151	16
49152	20
49154	25
49155	30
49156	35
49157	40
49158	45
49159	50

### 14MM 2.0 Pitch

49491	30MM
49492	40
49493	50
49494	60

49489 Asst. avail.



For use with metric Hex Keys

Qual # Lgth

### 8MM 1.25 Pitch

49165	12MM
49166	16
49167	20
49169	25
49170	30
49171	35
49172	40
49173	45
49174	50

### 10MM 1.5 Pitch

49526	16MM
49480	20
49481	25
49482	30
49483	35
49484	40
49485	45
49486	50
49487	60

### 12MM 1.75 Pitch

49527	25MM
49528	30
49529	40

C/S Head Dia. Socket Key

4 MM	3 MM
5	4
6	5
8	6
10	8
12	10

## THREADED ROD

Qual # Coarse

49700	4 x	.70
49701	5 x	.80
49702	6 x	1.00
49703	7 x	1.00
49704	8 x	1.25
49687	10 x	1.50
49688	12 x	1.75
49689	14 x	2.00
49692	16 x	2.00
48720	18 x	2.50
48721	20 x	2.50
48722	22 x	2.50
48723	24 x	3.00

Qual # Fine

48730	8 x	1.00
48731	10 x	1.25
48732	10 x	1.00
48733	12 x	1.50
48734	12 x	1.25
48735	14 x	1.50
48736	16 x	1.50
48737	18 x	1.50

## Metric

### METRIC J.I.S. SMALL HEAD CAP SCREWS

Steel, Zinc Plated, I.S.O. Class 8.8 J.I.S. B 1180 fasteners have smaller hex dimension (across the flats) than DIN or ISO metric fasteners. J.I.S. fasteners are OEM equipment on many GM and Japanese import car applications.

Qual #	DIA & Pitch	Lgth MM	Bx	Qual #	DIA & Pitch	Lgth MM	Bx	Qual #	DIA & Pitch	Lgth MM	Bx	Qual #	DIA & Pitch	Lgth MM	Bx
41777		16	25	41787		20	25	41793		50	15	43612		35	10
41778		20	25	41788		25	25	41794	10MM 1.25 (14mm HEX)	60	10	43613	12mm 1.25 (17mm HEX)	40	10
41779		25	25	41789	10MM, 1.25 (14mm HEX)	30	25	41795		70	10	43614		50	10
41780	8MM, 1.25 (12mm HEX)	30	25	41790		35	15	43609	12mm 1.25 (17mm HEX)	20	10				
41781		35	25	41791		40	15	43610		25	10				
41782		40	25	41792		45	15	43611		30	10				
41784		50	25												



### METRIC J.I.S. SMALL HEX NUTS

Qual #	DIA & Pitch	Hex Width	Bx
41796	8mm-1.25	12mm	25
41797	10mm-1.25	14mm	15
43617	12mm-1.25	17mm	25



### HEX FLANGE NUT

Qual #: 45253, M10-1.25, bx/50



### METRIC J.I.S. SMALL HEAD HEX FLANGE BOLTS

Qual #	Size	Hex Size	Flange O.D.	Bx	Qual #	Size	Hex Size	Flange O.D.	Bx
44315	M6-1.0x12mm			50	44388	M8-1.25x20mm			15
44316	M6-1.0x16mm			50	44389	M8-1.25x30mm	12 mm	17.5 mm	15
45807-A	M6-1.0x20mm	10 mm	14 mm	50	44390	M8-1.25x40mm			15
45808-A	M6-1.0x30mm			25	44188	M10-1.25x16mm	14 mm	20 mm	10
45809-A	M6-1.0x40mm			25	44189	M10-1.25x20mm			10
45980	M8-1.25x12mm	12 mm	17.5 mm	25	44190	M10-1.25x30mm			10
44387	M8-1.25x16mm			15	44191	M10-1.25x40mm			10



## Metric Machine Screws

### PHILLIPS BINDING HEAD DIN 7985

#### 4MM Dia. 0.70 Pitch

Qual #	Lgth
49337	6MM
49338	8
49339	10
49340	12
49341	16
49342	20

#### 5MM Dia. 0.80 Pitch

Qual #	Lgth
49680	10 MM
49681	12
49682	16
49683	20
49684	25
49685	30
49674	35
49686	50

#### 6MM Dia. 1.0 Pitch

Qual #	Lgth
49343	10MM
49344	12
49345	16
49346	20
49347	25
49348	30
49675	35
49676	40
49677	45
49324	50

### SLOTTED BINDING HEAD DIN 85

#### 4MM Dia. 0.70 Pitch

Qual #	Lgth
49000	6 MM
49001	8
49002	10
49003	16
49004	20
49005	25
49006	30

#### 5MM Dia. 0.80 Pitch

Qual #	Lgth
49010	6MM
49011	8
49012	10
49013	12
49014	16
49015	20
49016	25
49017	30

#### 6MM Dia. 1.0 Pitch

Qual #	Lgth
49025	8MM
49026	10
49027	12
49028	16
49029	18
49030	20
49031	22
49032	25
49033	30
49034	35
49035	40
49036	50
49037	60

#### 8MM 1.25 Pitch

Qual #	Lgth
49040	10MM
49041	12
49042	16
49043	20

#### 10MM 1.5 Pitch

Qual #	Lgth
49050	12MM
49051	16
49052	20

49055 Asst 24 popular sizes

Qual #: 49351

Asst 15 sizes of 4MM

Qual #: 49352

Asst 14 sizes of 5&6 MM

Qual #: 49353

Asst 24 sizes



# Metric Machine Screws

## PHILLIPS OVAL HEAD DIN 966

### 4MM Dia. 0.70 Pitch

Qual#	Lgth
49650	6MM
49651	8
49652	10
49654	16
49655	20
49656	25

### 5MM Dia. 0.80 Pitch

Qual#	Lgth
49658	10MM
49659	16
49660	20
49661	25
49662	30

### 8MM 1.25 Pitch

Qual#	Lgth
49570	16MM
49571	20
49572	25
49573	30
49574	35
49575	40

### 6MM Dia. 1.0 Pitch

Qual#	Lgth
49565	10MM
49664	12
49665	16
49666	20
49667	25
49668	30
49566	35
49567	40
49568	45
49569	50

Qual #: 49669

Assortment  
Contains 14 sizes of 4,5, & 6MM

Qual #: 49670

Assortment  
Contains 10 sizes of 5 & 6MM

Qual #: 49671

Assortment  
Contains 24 sizes of 4,5, & 6MM

## SLOTTED PAN HEAD DIN 84

### 4MM Dia. 0.70 Pitch

Qual#	Lgth
49292	6MM
49293	8
49294	10
49295	12
49296	16
49297	20
49316	25
49317	30
49318	35

### 5MM Dia. 0.80 Pitch

Qual#	Lgth
49438	10MM
49439	16
49441	20
49442	25
49443	30

### 6MM Dia. 1.0 Pitch

Qual#	Lgth
49319	8MM
49690	10
49320	12
49691	16
49693	20
49694	25
49695	30
49321	40
49322	50

### 8MM 1.25 Pitch

Qual#	Lgth
49771	16MM
49772	20
49773	25
49775	30
49776	35
49777	40

Qual #: 49298

Assortment  
Contains 12 sizes of 4,5, & 6 MM

Qual #: 49299

Assortment  
Contains 12 sizes of 5 & 6 MM

Qual #: 49274

Assortment  
Contains 24 sizes of 4, 5, & 6 MM

# Metric Thread Cutting Screws

## PAN HEAD - PERMAPLATED DIN 7513B

### 2.5MM Dia 0.45 Thread Pitch

Qual#	Lgth
49538	10MM
49539	12
49540	16
49541	20

### 3MM Dia. 0.5 Thread Pitch

Qual#	Lgth
49542	10MM
49543	12
49544	16
49545	20

### 4MM Dia. 0.7 Thread Pitch

Qual#	Lgth
49546	10MM
49547	12
49548	16
49549	20



Qual #: 49550

Assortment - Contains all sizes listed

## HEX HEAD- PERMAPLATED DIN 7513A

Qual#	Diameter	Thread Pitch	Lgth
49532	4MM	0.7	16 MM
49533	5	0.8	16
49534	6	1.0	16
49535	6	1.0	20



## Toggles, Toggle Bolts, Anchors

### KAP TOGGLE

25/Pkg



Qual#	Lgth	with/ screw	Hole Size
15050	1/8	x2	* 3/8
15051	3/16	x2	* 1/2
15052	1/4	x2	* 5/8
15053	1/8	x2	3/8
15054	3/16	x2	1/2
15055	1/4	x2	5/8

### NYLON ANCHORS

#### Flat Head

Qual#	Size
13363	3/16 x 1
13364	3/16 x 1-1/2
13365	1/4 x 1
13366	1/4 x 1-1/2



#### Round Head

13372	3/16 x 1
13373	3/16 x 1-1/2
13374	1/4 x 1
13375	1/4 x 1-1/2



#### Mushroom Head

13367	3/16 x 1
13368	1/4 x 1/2
13369	1/4 x 3/4
13370	1/4 x 1
13371	1/4 x 2



### TOGGLE BOLTS

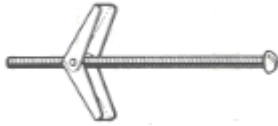

Size	Round Head	Flat Head	Mushroom Head
1/8	x2	15128	15148
	x3	15129	15149
	x4	15130	15150
	x5	15131	15151
	x6	15132	15152
3/16	x2	15131	15151
	x3	15132	15152
	x4	15133	15153
	x5	15134	15154
	x6	15135	15155
1/4	x3	15136	15156
	x4	15137	15157
	x5	15138	15158
	x6	15139	15159
	x3	15140	15160
	x4	15141	15161
5/16	x5	15142	15162
	x6	15143	15163
	x3	15144	15164
	x4	15145	15165
	x5	15146	15166
	x6	15147	15167

### TOGGLE HEAD ONLY



#### Toggle Head Only

15174
15174
15174
15175
15175
15175
15175
15175
15176
15176
15176
15176
15176
15177
15177
15177
15177
15177
15178
15178
15178
15178
15178

### ANCHORS



Qual#	Size	Hole Size	Anchor Lgth	Wall Thickness
15056	1/8	5/16	1-1/4	1/8-5/8
15057	1/8	5-16	1-3/4	5/8-1-1/4
15058	3/16	7/16	2	1/8-5/8
15059	3/16	7/16	2-1/2	5/8-1-1/4
15060	1/4	1/2	2	1/8-5/8
15061	1/2	1/2	2-1/2	5/8-1-1/4
*15062	1/8	5/16		1/8-5/8
*15063	1/8	5/16		5/8-1-1/4



### PLASTIC SNAP TOGGLE

Use with #8 sheet metal screw Pkg 25

Qual#	Size	Wall Thickness
23980	8x 3/8	3/8
23981	8x 1/2	1/2
23982	8x 5/8	5/8



### PLASTIC SCREW ANCHOR Pkg 100

Use with wood or sheet metal screws

Qual#	Size
13240	6-8
13241	8-10
13242	10-12
13243	14-16



### EXPANSION BOLT ANCHORS



Qual#	Anchor & Drill Size	Anchor Lgth	Min. Hole Depth	Max. Thickness of Material to be Fastened	Pk
11672	5/16	1-1/2	1"	1/2	25
11674	5/16	2-1/2	1"	1-1/2	25
11675	3/8	1-7/8	1-1/4	5/8	25
11676	3/8	3"	1-1/4	1-3/4	25
11677	1/2	2-1/4	1-1/2	3/4	15
11679	1/2	2-3/4	1-1/2	1-1/4	15
11680	1/2	4"	1-7/8	2-1/2	15
11681	5/8	2-1/4	2"	1/4	10
11682	5/8	4-1/4	2"	2-1/4	10
11683	5/8	5-3/4	2"	3-3/4	10
11684	3/4	2-1/2	2"	1/2	10
11685	3/4	4-1/4	2"	1-3/4	5
11686	3/4	6-1/4	2"	3-3/4	5

### THUNDERDRILL

Self-Drilling Anchor, Snap-off Anchor

Qual#	Size	Pk
23974	1/4	25
23975	5/16	25
23976	3/8	15
23977	1/2	10
23978	5/8	10
23979	3/4	5



### THUNDERTITE SETTING TOOL Pkg 1

Qual#	Size
23965	6-32
23966	8-32
23967	10-24
23968	10-32
23969	10-24
23970	1/4"
23971	5/16"
23972	3/8"
23973	1/2"



### DOUBLE THUNDERLOC

Double Expansion Bolt Shields

Qual#	Size	Hole Size	Anchor Lgth	Pk
23950	1/4	1/2	1-3/8	25
23951	5/16*	5/8	1-3/4	15
23952	3/8*	3/4	2-1/16	15
23953	1/2	7/8	2-1/2	10
23954	5/8	1"	3"	10
23955	3/4	1-1/4	4"	5

\*These sizes constructed with one circular spring.

### THUNDERTITE Machine Screw Anchor

Qual#	Size	Hole Size	Anchor Lgth	Pk
23956	6-32	5/16	17/32	50
23957	8-32	5/16	17/32	50
23958	10-24	3/8	11/16	50
23959	10-32	3/8	11/16	50
23960	12-24	1/2	7/8	25
23961	1/4	1/2	7/8	25
23962	5/16	5/8	1-1/16	25
23963	3/8	3/4	1-5/16	15
23964	1/2	7/8	1-9/16	15





## VINYL SCREW ANCHORS



Color coded for size identification. Unaffected by moisture or corrosion and is shock and vibration proof. Temp. range -70 to +220 F. Easy to use. Permits flush mounting and will not flatten out when driven into hole.

Qual#	Screw Size	Anchor Length	Drill Size Plaster	Concrete	Safe Working Loads(lb)	Pkg	Color Code
11691	1-2-3	1"	5/32	1/8	62	50	Yellow
11692	4-5-6	1"	13/64	3/16	85	50	White
11693	7-8-9	1"	15/64	1/4	136	50	Red
11695	7-8-9	1-1/2	15/64	1/4	136	50	Red
11696	10-12	1"	9/32	9/32	223	50	Green
11697	10-12	1-1/4	9/32	9/32	223	50	Green
11698	10-12	1-1/2	9/32	9/32	223	50	Green
11707	3/16	2"	9/32	9/32	223	50	Green
11708	14 & 1/4	1"	5/16	5/16	267	50	Blue
11709	14 & 1/4	1-1/2	5/16	5/16	267	50	Blue
11712	14 & 1/4	2"	5/16	5/16	267	50	Blue
11713	14 & 1/4	2-1/4	5/16	5/16	267	25	Blue
11714	16-18	1-1/2	5/16	3/8	392	25	Orange
11715	16-18	2"	5/16	3/8	392	25	Orange
11716	5/16	2-1/2	5/16	3/8	392	25	Orange
11717	20-24	2"	5/16	7/16	537	25	Gray
11718	20-24	2-1/2	5/16	7/16	537	25	Gray
11719	3/8	3"	5/16	7/16	537	25	Gray
11720	7/16	2-1/2	5/16	5/8	658	15	Black
11721	1/2	3-1/2	5/16	5/8	658	15	Black

## LAG SCREW SHIELDS

Qual#	Size	Hole Size	Anchor Lgth	Pkg
11601	1/4-SHORT	1/2	1"	25
11602	5/16-SHORT	1/2	1-1/4	25
11603	3/8-SHORT	5/8	1-3/4	25
11604	1/2-SHORT	3/4	2"	25
11605	1/4-LONG	1/2	1-1/2	25
11606	5/16-LONG	1/2	1-3/4	25
11607	5/8-LONG	5/8	2-7/16	15
11608	1/2-LONG	3/4	3-1/2	15



## THREADED ROD PLATED

Three Foot Lengths



USS Grade 2			USS			Threaded Rod Grade 8 Alloy			SAE			Stainless Steel		
Qual#	Diameter	Thread	Qual#	Diameter	Thread	Qual#	Diameter	Thread	Qual#	Diameter	Thread	Qual#	Diameter	Thread
13166	1/4	1/4-20	15007	1/4	1/4-20	15013	1/4	1/4-28	13210	1/4				
13167	5/16	5/16-18	15008	5/16	5/16-18	15014	5/16	5/16-24	13211	5/16				
13168	3/8	3/8-16	15009	3/8	3/8-16	15015	3/8	3/8-24	13212	3/8				
13169	7/16	7/16-14	15010	7/16	7/16-14	15016	7/16	7/16-20	13213	7/16				Sizes avail. as special order items
13170	1/2	1/2-13	13196	1/2	1/2-13	15017	1/2	1/2-20	13214	1/2				
13171	9/16	9/16-12	13197	5/8	5/8-11	15019	5/8	5/8-18	13215	9/16				
13172	5/8	5/8-11	13198	3/4	3/4-10	15020	3/4	3/4-16	13216	5/8				
13173	3/4	3/4-10	13199	7/8	7/8-9	15021	7/8	7/8-14	13217	3/4				
13174	7/8	7/8-9	13200	1	1-8	15022	1	1-14						
13175	1	1-8												

## HEX HEAD LAG SCREWS

Low Carbon Steel, Zinc Plated, Iridite Dipped, Sharp Gimlet Point

1/4" Diameter			5/16" Diameter			3/8" Diameter			1/2" Diameter		
Qual#	Lgth	Pkg	Qual#	Lgth	Pkg	Qual#	Lgth	Pkg	Qual#	Lgth	Pkg
15179	1	50	15214	1	50	15193	2	50	15199	2	25
15180	1-1/4	50	15215	1-1/2	50	15194	2-1/2	50	15200	2-1/2	25
15181	1-1/2	50	15187	2	50	15195	3	50	15201	3	25
15182	2	50	15188	2-1/2	50	15196	3-1/2	50	15202	4	25
15183	2-1/2	50	15189	3	50	15197	4	25	15203	5	25
15184	3	50	15190	3-1/2	50	15198	5	25	15208	6	25
15185	3-1/2	50	15191	4	50	15206	6	25			
15186	4	50	15192	5	50	15207	7	25			
15204	5	50									
15205	6	50									





# Hexagon Head Cap Screws 1038 Steel Double Heat Treated, Platted USS & SAE, Grade 5

## 1/4" DIAMETER

USS	SAE	Lgth	Pkg
6006	6506	1/2	100
6010	6510	3/4	100
6012	6512	1	100
6014	6514	1-1/4	100
6016	6516	1-1/2	100
6018	6518	1-3/4	100
6020	6520	2	100
6022	6522	2-1/4	50
6024	6524	2-1/2	50
6026	6526	2-3/4	50
6028	6528	3	50
6030	6530	3-1/4	50
6032	6532	3-1/2	50
6036	6536	4	50
6038	6538	4-1/2	50
6040	6540	5	50

## 1/2" DIAMETER

USS	SAE	Lgth	Pkg
6210	6710	3/4	50
6212	6712	1	50
6214	6714	1-1/4	50
6216	6716	1-1/2	50
6218	6718	1-3/4	50
6220	6720	2	50
6222	6722	2-1/4	50
6224	6724	2-1/2	50
6226	6726	2-3/4	50
6228	6728	3	50
6230	6730	3-1/4	25
6232	6732	3-1/2	25
6234	6734	3-3/4	25
6236	6736	4	25
6238	6738	4-1/2	25
6240	6740	5	25
6242	6742	5-1/2	25
6244	6744	6	25
6248	6748	7	10
6252		8	10
6256		9	10
6260		10	10

## GRADE 5 ASSORTMENTS

10104	Bolts & Nuts	USS-SAE	1/4-1/2	18 Draw Steel Bin
10105	Bolts ,Nuts, Locks, & Flats	USS-SAE	1/4-1/2	18 Draw Steel Bin
10111	Bolts ,Nuts, Locks, & Flats	USS-SAE	1/4-1/2	72 Comp. Bin
10116	Bolts, Nuts	SAE only	1/4-3/4	72 Comp Bin
10108	Bolts, Nuts	USS only	1/4-3/4	72 Comp Bin
10109	Bolts, Nuts, Flats, Cotters	USS-SAE	1/4-1/2	18 Draw Steel Bin
10110	Custom Asst. Made to order. Any Size Bolt, Nut Wash & Cotter in 72 Hole Bin. Minimum 40 Sizes			
10112	Custom Asst. As above in 40 Hole Bin. 30 Size minimum			
10113	Custom Asst. As above in 18 Draw Cabinet. 30 Size minimum			

## 5/16" DIAMETER

USS	SAE	Lgth	Pkg
6056	6556	1/2	100
6060	6560	3/4	100
6062	6562	1	100
6064	6564	1-1/4	100
6066	6566	1-1/2	100
6068	6568	1-3/4	100
6070	6570	2	100
6072	6572	2-1/4	50
6074	6574	2-1/2	50
6076	6576	2-3/4	50
6078	6578	3	50
6080	6580	3-1/4	50
6082	6582	3-1/2	50
6084	6584	3-3/4	50
6086	6586	4	50
6088	6588	4-1/2	50
6090	6590	5	50
6092	6592	5-1/2	50
6094	6594	6	50

## 5/8" DIAMETER

USS	SAE	Lgth	Pkg
6312	6812	1	25
6314	6814	1-1/4	25
6316	6816	1-1/2	25
6318	6818	1-3/4	25
6320	6820	2	25
6322	6822	2-1/4	25
6324	6824	2-1/2	25
6326	6826	2-3/4	25
6328	6828	3	25
6330	6830	3-1/4	25
6332	6832	3-1/2	25
6334	6834	3-3/4	25
6336	6836	4	25
6338	6838	4-1/2	25
6340	6840	5	25
6342	6842	5-1/2	25
6344	6844	6	25
6348		7	10
6352		8	10
6356		9	10
6360		10	10

## 3/8" DIAMETER

USS	SAE	Lgth	Pkg
6106	6606	1/2	100
6110	6610	3/4	100
6112	6612	1	100
6114	6614	1-1/4	100
6116	6616	1-1/2	50
6118	6618	1-3/4	50
6120	6620	2	50
6122	6622	2-1/4	50
6124	6624	2-1/2	50
6126	6626	2-3/4	50
6128	6628	3	50
6130	6630	3-1/4	50
6132	6632	3-1/2	50
6134	6634	3-3/4	50
6136	6636	4	25
6138	6638	4-1/2	25
6140	6640	5	25
6142	6642	5-1/2	25
6144	6644	6	25

## 9/16" DIAMETER

USS	SAE	Lgth	Pkg
6262	6762	1	25
6264	6764	1-1/4	25
6266	6766	1-1/2	25
6268	6768	1-3/4	25
6270	6770	2	25
6272	6772	2-1/4	25
6274	6774	2-1/2	25
6276	6776	2-3/4	25
6278	6778	3	25
6280	6780	3-1/4	25
6282	6782	3-1/2	25
6284	6784	3-3/4	25
6286	6786	4	25
6288	6788	4-1/2	25
6290	6790	5	25
6292	6792	5-1/2	25
6294	6794	6	25

## 7/8" DIAMETER

USS	SAE	Lgth	Pkg
6420	6920	2	15
6424	6924	2-1/2	15
6428	6928	3	15
6432	6932	3-1/2	15
6436	6936	4	15
6438	6938	4-1/2	15
6440	6940	5	15
6444	6944	6	15

## 7/16" DIAMETER

USS	SAE	Lgth	Pkg
6160	6660	3/4	50
6162	6662	1	50
6164	6664	1-1/4	50
6166	6666	1-1/2	50
6168	6668	1-3/4	50
6170	6670	2	50
6172	6672	2-1/4	50
6174	6674	2-1/2	50
6176	6676	2-3/4	50
6178	6678	3	50
6180	6680	3-1/4	25
6182	6682	3-1/2	25
6184	6684	3-3/4	25
6186	6686	4	25
6188	6688	4-1/2	25
6190	6690	5	25
6192	6692	5-1/2	25
6194	6694	6	25
6196	6696	6-1/2	10
6198	6698	7	10

## 3/4" DIAMETER

USS	SAE	Lgth	Pkg
6362	6862	1	20
6364	6864	1-1/4	20
6366	6866	1-1/2	20
6368	6868	1-3/4	20
6370	6870	2	20
6372	6872	2-1/4	20
6374	6874	2-1/2	20
6376	6876	2-3/4	20
6378	6878	3	20
6380	6880	3-1/4	20
6382	6882	3-1/2	20
6384	6884	3-3/4	20
6386	6886	4	20
6388	6888	4-1/2	20
6390	6890	5	20
6392	6892	5-1/2	20
6394	6894	6	20

## 1" DIAMETER

USS	SAE	Lgth	Pkg
6470	6970	2	10
6474	6974	2-1/2	10
6478	6978	3	10
6482	6982	3-1/2	10
6486	6986	4	10
6488	6988	4-1/2	10
6490	6990	5	10
6494	6994	6	10
6496		7	10

# Hexagon Head Cap Screws USS & SAE, Grade 8 Alloy



## 1/4" DIAMETER

USS	SAE	Lgth	Pkg
7006	7506	1/2	100
7010	7510	3/4	100
7012	7512	1	100
7014	7514	1-1/4	100
7016	7516	1-1/2	100
7018	7518	1-3/4	100
7020	7520	2	100
7022	7522	2-1/4	50
7024	7524	2-1/2	50
7026	7526	2-3/4	50
7028	7528	3	50
7030	7530	3-1/4	50
7032	7532	3-1/2	50
7036	7536	4	50
7038	7538	4-1/2	50
7040	7540	5	50
7042	7542	5-1/2	50
7044	7544	6	50

## 1/2" DIAMETER

USS	SAE	Lgth	Pkg
7210	7710	3/4	50
7212	7712	1	50
7214	7714	1-1/4	50
7216	7716	1-1/2	50
7218	7718	1-3/4	50
7220	7720	2	50
7222	7722	2-1/4	50
7224	7724	2-1/2	50
7226	7726	2-3/4	50
7228	7728	3	50
7230	7730	3-1/4	25
7232	7732	3-1/2	25
7236	7736	4	25
7238	7738	4-1/2	25
7240	7740	5	25
7242	7742	5-1/2	25
7244	7744	6	25
7248	7748	7	10
7252	7752	8	10
7256	7756	9	10
7258	7758	10	10

Meets or exceeds the following government & industrial physical specifications.

1. SAE Gr8 (Soc. of Automotive Engineers)
2. A.N.S.I. B18.2.1 (Amer. National Standards Institute)
3. GM 300 M (General Motors)
4. IH Type 4 (International Harvester)
5. CAT E60 (Caterpillar)
6. Ford M3500G
7. JDM A17F (John Deere)
8. MIL B-857 (Government)
9. FF-S-85 (Federal)
10. MIL B857-A (Military)

## 5/16" DIAMETER

USS	SAE	Lgth	Pkg
7056	7556	1/2	100
7060	7560	3/4	100
7062	7562	1	100
7064	7564	1-1/4	100
7066	7566	1-1/2	100
7068	7568	1-3/4	100
7070	7570	2	100
7072	7572	2-1/4	50
7074	7574	2-1/2	50
7076	7576	2-3/4	50
7078	7578	3	50
7080	7580	3-1/4	50
7082	7582	3-1/2	50
7086	7586	4	50
7088	7588	4-1/2	50
7090	7590	5	50
7092	7592	5-1/2	50
7094	7594	6	50

## 9/16" DIAMETER

USS	SAE	Lgth	Pkg
7262	7762	1	25
7264	7764	1-1/4	25
7266	7766	1-1/2	25
7268	7768	1-3/4	25
7270	7770	2	25
7272	7772	2-1/4	25
7274	7774	2-1/2	25
7276	7776	2-3/4	25
7278	7778	3	25
7282	7782	3-1/2	25
7286	7786	4	25
7288	7788	4-1/2	25
7290	7790	5	25
7292	7792	5-1/2	25
7294	7794	6	25
7298	7798	7	10
7302	7802	8	10

## 1" DIAMETER

USS	SAE	Lgth	Pkg
7470	7970	2	10
7474	7974	2-1/2	10
7478	7978	3	10
	7979	3-1/4	10
7482	7982	3-1/2	10
7486	7986	4	10
7488	7988	4-1/2	10
7490	7990	5	10
	7991	5-1/2	10
7494	7994	6	10
7496	7996	6-1/2	1
7498	7995	7	1
7502	7992	8	1
7503	7997	9	1
7504	7998	10	1

## 3/8" DIAMETER

USS	SAE	Lgth	Pkg
7108	7608	1/2	100
7110	7610	3/4	100
7112	7612	1	100
7114	7614	1-1/4	100
7116	7616	1-1/2	50
7118	7618	1-3/4	50
7120	7620	2	50
7122	7622	2-1/4	50
7124	7624	2-1/2	50
7126	7626	2-3/4	50
7128	7628	3	50
7130	7630	3-1/4	50
7132	7632	3-1/2	50
7136	7636	4	25
7138	7638	4-1/2	25
7140	7640	5	25
7142	7642	5-1/2	25
7144	7644	6	25
7146	7646	6-1/2	10
7148	7648	7	10
7152	7652	8	10

## 5/8" DIAMETER

USS	SAE	Lgth	Pkg
7312	7812	1	25
7314	7814	1-1/4	25
7316	7816	1-1/2	25
7318	7818	1-3/4	25
7320	7820	2	25
7322	7822	2-1/4	25
7324	7824	2-1/2	25
7326	7826	2-3/4	25
7328	7828	3	25
7332	7832	3-1/2	25
7336	7836	4	25
7338	7838	4-1/2	25
7340	7840	5	25
7342	7842	5-1/2	25
7344	7844	6	25
7348	7848	7	10
7352	7852	8	10
7356	7856	9	10
7360	7860	10	10

## ASSORTMENTS

Part No.	SAE	Lgth	Material	Pkg
10117	1-4-1/2	USS		
10118	1-4-1/2	USS & SAE		
10119	1/4-3/4	USS & SAE		
10120	Custom	30 size	Minimum	
10121	Custom	40 size	Minimum	

## 7/16" DIAMETER

USS	SAE	Lgth	Pkg
7160	7660	3/4	50
7162	7662	1	50
7164	7664	1-1/4	50
7166	7666	1-1/2	50
7168	7668	1-3/4	50
7170	7670	2	50
7172	7672	2-1/4	50
7174	7674	2-1/2	50
7178	7678	3	50
7182	7682	3-1/2	25
7186	7686	4	25
7188	7688	4-1/2	25
7190	7690	5	25
7192	7692	5-1/2	25
7194	7694	6	25
7198	7698	7	10
7202	7702	8	10

## 3/4" DIAMETER

USS	SAE	Lgth	Pkg
7362	7862	1	20
7364	7864	1-1/4	20
7366	7866	1-1/2	20
7368	7868	1-3/4	20
7370	7870	2	20
7372	7872	2-1/4	20
7374	7874	2-1/2	20
7376	7876	2-3/4	20
7378	7878	3	20
7382	7882	3-1/2	20
7386	7886	4	20
7388	7888	4-1/2	20
7390	7890	5	20
7392	7892	5-1/2	20
7394	7894	6	20
7396	7896	6-1/2	10
7398	7898	7	10
7402	7902	8	10
7406	7906	9	10
7410	7910	10	10

## 7/8" DIAMETER

USS	SAE	Lgth	Pkg
7420	7920	2	15
7424	7924	2-1/2	15
7428	7928	3	15
7432	7932	3-1/2	15
7436	7936	4	15
7438	7938	4-1/2	15
7440	7940	5	15
7442		5-1/2	10
7444	7944	6	15
7448	7948	7	1
7452	7952	8	1
7456	7956	9	1
7460	7960	10	1

**Carriage Bolts No Nuts**

**3/16" DIAMETER**

Qual#	Lgth	Pkg
8124	1	100

**1/2" DIAMETER**

Qual#	Lgth	Pkg
8165	1	50
8166	1-1/2	50
8167	2	25
8168	2-1/2	25
8169	3	25
8170	3-1/2	25
8171	4	25
8172	4-1/2	25
8173	5	15
8174	5-1/2	15
8175	6	15



**1/4" DIAMETER**

Qual#	Lgth	Pkg
8110	1	100
8111	1-1/4	100
8112	1-1/2	100
8114	1-3/4	100
8116	2	100
8117	2-1/2	100
8118	3	100
8119	3-1/2	50
8120	4	50
8121	5	50
8122	6	50
8123	7	25

**5/8" DIAMETER**

Qual#	Lgth	Pkg
8180	1-1/2	25
8181	2	25
8182	3	15
8183	4	15
8184	5	15
8185	6	15

**5/16" DIAMETER**

Qual#	Lgth	Pkg
8125	1	100
8127	1-1/2	100
8128	2	100
8129	2-1/2	50
8130	3	50
8131	3-1/2	50
8132	4	50
8133	4-1/2	25
8134	5	25
8136	6	25

**3/4" DIAMETER**

Qual#	Lgth	Pkg
8190	2	10
8191	3	10
8192	4	10
8193	5	10
8194	6	10

**3/8" DIAMETER**

Qual#	Lgth	Pkg
8140	1	100
8141	1-1/4	50
8142	1-1/2	50
8144	2	50
8145	2-1/2	50
8146	3	50
8147	3-1/2	50
8148	4	25
8149	4-1/2	25
8150	5	25
8151	5-1/2	25
8152	6	25

**7/16" DIAMETER**

Qual#	Lgth	Pkg
8155	1-1/2	50
8156	2	50
8157	2-1/2	25
8158	3	25
8159	3-1/2	25
8160	4	25
8161	5	25
8162	6	25

**GR8 FULL THREAD TAP BOLT Pkg 10**

Qual#	SIZE
8044	1/4-20 x 6
8094	5/16-18 x 6
8095	3/8-16 x 6
8097	7/16-14 x 6
8098	1/2-13 x 6

Assortment 10114 includes 5 pcs of each size above in 10040 Bin



**REVERSIBLE LOCK NUT**



Qual#	Size	Gr 2	Bx
38740	1/4-20		100
38741	5/16-18		100
38742	3/8-16		50
38743	1/2-13		25
38744	5/8-11		25

**Giant Size Cap Screws USS & SAE, Grade 8, Alloy**

**1-1/8" DIAMETER Pkg 1**

USS	SAE	Lgth
8355	8755	3
8356	8756	4
8357	8757	5
8358	8758	6
8359	8759	7
8360	8760	8
8361	8761	9
8362	8762	10
8363	8763	12

**1-1/4" DIAMETER Pkg 1**

USS	SAE	Lgth
8365	8765	3
8366	8766	4
8367	8767	5
8368	8768	6
8369	8769	7
8370	8770	8
8371	8771	9
8372	8772	10
8373	8773	12
8374		13

**1-1/2" DIAMETER Pkg 1**

USS	SAE	Lgth
8380	8780	3
8381	8781	4
8382	8782	5
8383	8783	6
8384	8784	7
8385	8785	8
8386	8786	9
8387	8787	10
8388	8788	12

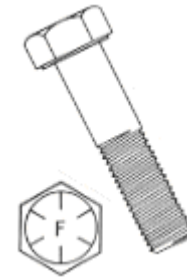

**Hex Nuts**

**FINISHED STEEL ZINC PLATED**

USS			SAE		
Qual#	Size	Pkg	Qual#	Size	Pkg
1500	1/4-20	100	1600	1/4-28	100
1501	5/16-18	100	1601	5/16-24	100
1502	3/8-16	100	1602	3/8-24	100
1503	7/16-14	50	1603	7/16-20	50
1504	*7/6-14	50	* Old Style 5/8 Hex		
1505	1/2-13	50	1605	1/2-20	50
1506	9/16-12	25	1606	9/16-18	25
1507	5/8-11	25	1607	5/8-18	25
1508	3/4-10	20	1608	3/4-16	20
1509	7/8-9	15	1609	7/8-14	15
1510	1-8	10	1610	1-14	10
1511	1-1/8-7	5	1611	1-1/8-12	5
1512	1-1/4-7	5	1612	1-1/4-12	5

**ALLOY FINISHED FULL HEX NUTS GRADE 8**

USS			SAE		
Qual#	Size	Pkg	Qual#	Size	Pkg
2500	1/4-20	100	2600	1/4-28	100
2501	5/16-18	100	2601	5/16-24	100
2502	3/8-16	100	2602	3/8-24	100
2503	7/16-14	50	2603	7/16-20	50
2505	1/2-13	50	2605	1/2-20	50
2506	9/16-12	25	2606	9/16-18	25
2507	5/8-11	25	2607	5/8-18	25
2508	3/4-10	20	2608	3/4-16	20
2509	7/8-9	15	2609	7/8-14	15
2510	1-8	10	2610	1-14	10
2511	1-1/8-7	5	2611	1-1/8-12	5
2512	1-1/4-7	5	2612	1-1/4-12	5
2513	1-1/2-6	5	2613	1-1/2-12	5

**QUANTITY**  
(check for avail.)  
(-K) 250  
(-L) 100  
(-M) 500  
(-N) 200  
(-O) 1000  
(-P) 300  
(-Q) 50



## Lock Nuts

### STOVER L9 HEX COLLAR

\* (-1) # Bx/ 100



USS			SAE		
Qual#	Size	Bx	Qual	Size	Bx
*8330	1/4-20	50	8340	1/4-28	50
*8331	5/16-18	50	8341	5/16-24	50
*8332	3/8-16	50	8342	3/8-24	50
*8333	7/16-14	25	8343	7/16-20	25
*8334	1/2-13	25	8344	1/2-20	25
8335	9/16-12	25	8345	9/16-18	25
8336	5/8-11	25	8346	5/8-18	25
8337	3/4-10	15	8347	3/4-16	15
8338	7/8-9	10	8348	7/8-14	10
8339	1-8	5	8349	1-14	5
8475	1-1/8	1	8480	1-1/8	1
8476	1-1/4	1	8481	1-1/4	1
8477	1-1/2	1	8482	1-1/2	1

### STOVER GRADE C

for Gr5 & Gr8 Bolts, Automation Style

\* (-1) # Bx/ 100

USS			SAE		
Qual#	Size	Bx	Qual#	Size	Bx
*8310	1/4-20	50	*8320	1/4-28	50
*8311	5/16-18	50	*8321	5/16-24	50
*8312	3/8-16	50	*8322	3/8-24	50
*8313	7/16-14	25	*8323	7/16-20	25
*8314	1/2-13	25	*8324	1/2-20	25
*8315	9/16-12	25	*8325	9/16-18	25
*8316	5/8-11	25	*8326	5/8-18	25
*8317	3/4-10	15	8327	3/4-16	15
*8318	7/8-9	15	8328	7/8-14	15
8319	1-8	10	8329	1-14	10

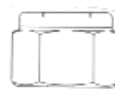

### NYLON INSERT Steel Zinc Plated

USS			SAE		
Gr 8	Gr 2	Gr 2	Gr 8	Gr 2	Gr 2
Qual#	Size	Qual#	Qual#	Size	Qual#
	6-32	1516			
	8-32	1517			
	10-24	1518		10-32	1618
1770	1/4-20	1519	1771	1/4-28	1619
1772	5/16-18	1520	1773	5/16-24	1620
1774	3/8-16	1521	1775	3/8-24	1621
1776	7/16-14	1522	1777	7/16-20	1622
1778	1/2-13	1523	1779	1/2-20	1623
1780	9/16-12	1524	1781	9/16-18	1624
1782	5/8-11	1525	1783	5/8-18	1625
1784	3/4-10	1526	1785	3/4-16	1626
1786	7/8-9	1527	1787	7/8-14	1627
1788	1-8	1528	1789	1-14	1628
	1-1/8-7	1529		1-1/8-12	1629
	1-1/4-7	1530		1-1/4-12	1630

## Special Nuts

### MACHINE SCREW NUTS

Pkg 100

Qual#	Size
1532	4-40
1533	6-32
1534	8-32
1535	10-32
1536	10-24
1537	12-24
1538	1/4-20

A-1024



### WING NUTS

Pkg 25 \* Bx10

Qual#	Size
1552	6-32
1553	8-32
1554	10-32
1555	10-24
1557	1/4-20
1558	5/16-18
1559	3/8-16
1561*	1/2-13
1556	12-24

A-1031



### KEPS HEX NUTS

Bx 50 A-1025

Qual#	Size
1540	6-32
1541	8-32
1542	10-32
1543	10-24
1544	1/4-20
1545	1/4-28
1546	5/16-18
1547	5/16-24
1548	3/8-16
1549	3/8-24



### PAL NUTS

Bx 50 \*Bx 25

Qual#	Size
1564	1/4-28
1565	5/16-24
1566	3/8-24
1567	7/16-20
1568	1/2-20
1569*	5/8-18
1570*	3/4-16

A-1042



### NYLON STOP NUTS WITH NYLON INSERTS

USS		Thin Jam		High Nylon	
Qual#	Size	Qual#	SAE	Qual#	SAE
1634	1/4-20	1734	1/4-28	1490	3/8-24
1635	5/16-18	1735	5-16-24	1491	7/16-20
1636	3/8-16	1736	3/8-24	1492	1/2-20
1637	7/16-14	1737	7/16-20	1493	9/16-18
1638	1/2-13	1738	1/2-20	1494	5/8-18
1639	9/16-12	1739	9/16-18	1495	3/4-16
1640	5/8-11	1740	5/8-18	1496	7/8-14
1641	3/4-10	1741	3/4-16	1497	1-14
1642	7/8-9	1742	7/8-14	1498	1-1/8-12
1643	1-8	1743	1-14	1499	1-1/4-12
		1744	1-1/8-12		
		1745	1-1/4-12		



### FINISHED HEX SLOTTED NUTS

USS			SAE		
Qual#	Size	Bx	Qual#	Size	Bx
1650	1/4-20	50	1750	1/4-28	50
1651	5/16-18	50	1751	5/16-24	50
1652	3/8-16	50	1752	3/8-24	50
1653	7/16-14	50	1753	7/16-20	50
1654	1/2-13	25	1754	1/2-20	25
1655	9/16-12	25	1755	9/16-18	25
1656	5/8-11	25	1756	5/8-18	25
1657	3/4-10	15	1757	3/4-16	15
1658	7/8-9	10	1758	7/8-14	10
1659	1-8	5	1759	1-14	5
			1760	1-1/8-12	5
			1761	1-1/4-12	5



### THIN FINISHED JAM HEX NUTS

USS			SAE		
Qual	Size	Bx	Qual	Size	Bx
8230	1/4-20	100	8240	1/4-28	100
8231	5/16-18	50	8241	5/16-24	50
8232	3/8-16	50	8242	3/8-24	50
8233	7/16-14	25	8243	7/16-20	25
8234	1/2-13	25	8244	1/2-20	25
8235	9/16-12	25	8245	9/16-18	25
8236	5/8-11	25	8246	5/8-18	25
8237	3/4-10	20	8247	3/4-16	20
8238	7/8-9	15	8248	7/8-14	15
8239	1-8	10	8249	1-14	10



### SAE HI NUT GRADE 5

SAE		
Qual	Size	Bx
1665	3/8-24	25
1666	7/16-20	25
1667	1/2-20	25
1668	9/16-18	20
1669	5/8-18	15
1670	3/4-16*	10
1671	7/8-14*	5
1672	1-14*	5

\*These sizes are stocked Grade 8 Alloy Steel only



### HEAVY HEX NUT

USS		
Qual#	Size	Bx
1675	1/4-20	50
1676	5/16-18	50
1677	3/8-16	50
1678	7/16-14	25
1679	1/2-13	25
1680	5/8-11	25
1681	3/4-10	15
1682	7/8-9	15
1683	1-8	10
1684	1-1/8-7	5
1685	1-1/4-7	5



## Stainless Steel 18-8, Marine Grade – Fully Finished

### HEX HEAD CAP SCREWS

#### USS COARSE THREAD

##### 1/4-20 DIAMETER

Qual#	Lgth	Pkg
4008	1/2	50
4010	3/4	50
4012	1"	50
4014	1-1/4	50
4016	1-1/2	50
4020	2"	25
4024	2-1/2	25
4028	3"	25
4029	3-1/2	15
4030	4"	15

##### 7/16-14 DIAMETER

Qual#	Lgth	Pkg
4150	1"	25
4151	1-1/2	25
4152	2"	15
4153	2-1/2	15
4154	3"	15
4155	3-1/2	10
4156	4"	10

##### 5/16-18 DIAMETER

Qual#	Lgth	Pkg
4058	1/2	50
4060	3/4	50
4062	1"	50
4064	1-1/4	50
4066	1-1/2	50
4070	2"	50
4074	2-1/2	25
4078	3"	25
4079	3-1/2	15
4080	4"	10
4081	5"	

##### 1/2-13 DIAMETER

Qual#	Lgth	Pkg
4212	1"	25
4214	1-1/4	25
4216	1-1/2	25
4220	2"	25
4224	2-1/2	25
4228	3"	15
4232	3-1/2	15
4236	4"	15
4237	4-1/2	10
4238	5"	10
4239	6"	10

##### 3/8-16 DIAMETER

Qual#	Lgth	Pkg
4110	3/4	25
4112	1"	25
4114	1-1/4	25
4116	1-1/2	25
4120	2"	25
4124	2-1/2	25
4128	3"	25
4136	4"	25
4137	4-1/2	10
4138	5"	10
4139	6"	10

##### 5/8-11 DIAMETER

Qual#	Lgth	Pkg
4254	1-1/2	10
4258	2"	10
4262	2-1/2	10
4266	3"	10
4270	3-1/2	10
4274	4"	10

##### 3/4-10 DIAMETER

Qual#	Lgth	Pkg
4312	2"	5
4316	2-1/2	5
4320	3"	5
4324	3-1/2	5
4328	4"	5

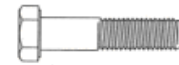

- **Non-Magnetic**
- **High corrosion resistance**
- **Finished Washer Face**
- **Chamfered Point**
- **Accurate formed threads**

### SAE FINE THREAD

##### 1/4-28 DIAMETER

Qual#	Lgth	Pkg
4180	1/2	25
4181	3/4	25
4182	1"	25
4183	1-1/2	25
4184	2"	25

##### 3/8-24 DIAMETER

Qual#	Lgth	Pkg
4200	3/4	25
4201	1"	25
4202	2"	15
4203	3"	15

##### 5/16-24 DIAMETER

Qual#	Lgth	Pkg
4190	1"	25
4191	1-1/2	25
4192	2"	25
4193	2-1/2	15
4194	3"	15

##### 7/16-20 DIAMETER

Qual#	Lgth	Pkg
4205	1"	15
4206	1-1/2	15
4207	2"	10
4208	3"	10

### COUNTERSUNK FINISHING WASHER

Qual#	Size	Pkg
4755	#6	100
4756	#8	100
4757	#10	100
4640	#12	100
4758	1/4	100



### WING NUTS

Qual#	Size	Pkg
4377	6-32	25
4378	8-32	25
4379	10-32	25
4380	10-24	25
4381	1/4-20	25
4382	5/16-18	20
4383	3/8-16	15
4384	1/2-13	10
4385	5/8-11	5



### LOCK WASHERS Medium

Qual#	Size	Pkg
4687	#4	250
4688	#6	250
4689	#8	250
4690	#10	250
4408	1/4	100
4409	5/16	100
4410	3/8	100
4389	7/16	50
4411	1/2	50
4416	5/8	20
4417	3/4	20



- **High strength**
- **High corrosion resistance**



## Stainless Steel 18-8, Marine Grade – Fully Finished

### FINISHED HEX NUTS

#### USS

Qual#	Size	Pkg
4400	1/4-20	50
4401	5/16-18	50
4402	3/8-16	25
4394	7/16-14	25
4403	1/2-13	25
4412	5/8-11	10
4413	3/4-10	10

#### SAE

Qual#	Size	Pkg
4395	1/4-28	100
4396	5/16-24	50
4397	3/8-24	25
4398	7/16-20	25
4399	1/2-20	25

- Non-Magnetic
- High corrosion resistance
- Double chamfer
- Burr free
- Class 2-B thread fit

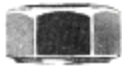

### NYLON INSERT LOCK NUTS

Qual#	Size	Pkg
4355	4-40	50
4356	6-32	50
4357	8-32	50
4358	10-32	50
4359	10-24	50
4360	1/4-20	25
4361	5/16-18	25
4362	3/8-16	10
4365	7/16-14	10
4363	1/2-13	10
4364	5/8-11	10
4330	3/4-10	10



### COTTER PINS

Qual#	Lgth	Pkg
4654	1/2	100
4655	3/4	100
4656	1"	100
4656A	1-1/4	100
4656B	1-1/2	100



### 3/32 DIAMETER

Qual#	Lgth	Pkg
4657	1/2	100
4658	3/4	100
4659	1"	100
4660	1-1/4	100
4661	1-1/2	50
4662	1-3/4	50
4663	2"	50
4663A	2-1/2	50

### 1/8 DIAMETER

Qual#	Lgth	Pkg
4666	1"	50
4667	1-1/4	50
4668	1-1/2	50
4669	1-3/4	50
4670	2"	25
4671	2-1/2	25
4671A	3"	25

### 5/32 DIAMETER

Qual#	Lgth	Pkg
4672	1"	50
4673	1-1/4	50
4674	1-1/2	50
4675	1-3/4	50
4676	2"	25
4677	2-1/2	25
4677A	3"	25

### 3/16 DIAMETER

Qual#	Lgth	Pkg
4678	1"	25
4679	1-1/2	25
4680	2"	25
4681	2-1/2	25
4682	3"	25
4683	3-1/2	25
4684	4"	25

- High strength
- Non-magnetic
- High corrosion resistance

### FLAT WASHER

Qual#	Size	Pkg
4685	#10	100
4686	#12	100
4404	1/4	100
4405	5/16	100
4406	3/8	100
4393	7/16	50
4407	1/2	25
4414	5/8	25
4415	3/4	10

- High strength
- Non-magnetic
- High corrosion resistance



### ACORN CAP NUTS

Closed End, Steel Nickel Plated

Qual#	Size	Pkg
4366	4-40	25
4367	6-32	25
4368	8-32	25
4369	10-32	25
4370	10-24	25
4371	1/4-20	25
4372	5/16-18	25
4373	3/8-16	15
4374	1/2-13	10
4375	5/8-11	10



## Stainless Steel 18-8 Sheet Metal Screws

### PHILLIPS OVAL HEAD



Qual#	Size	Pkg
4726A	4 x 3/8	100
4726B	1/2	100
4726C	5/8	100
4726D	1/4	100

Qual#	Size	Pkg
4726	6 x 1/2	50
4726E	5/8	50
4727	3/4	50
4726F	1	50
4726G	1-1/2	50

Qual#	Size	Pkg
4728	8 x 1/2	50
4729	3/4	50
4730	1	50
4731	1-1/4	50
4731A	1-1/2	50

Qual#	Size	Pkg
4732	10 x 1/2	50
4733	3/4	50
4734	1	50
4735	1-1/4	25
4735A	1-1/2	25
4735B	2	25
4735C	2-1/2	25
4735D	3	25

Qual#	Size	Pkg
4736A	12 x 1/2	50
4736	3/4	50
4736B	1	50
4737	1-1/4	25
4736C	1-1/2	25
4736D	2	25
4736E	3	25

Qual#	Size	Pkg
4738A	14 x 3/4	50
4738	1	50
4739	1-1/4	25
4738B	1-1/2	25
4738C	2	25
4738D	3	25

### PHILLIPS BINDING HEAD



Qual#	Size	Pkg
4692	6 x 1/2	50
4693	3/4	50
4693A	1	50
4693B	1-1/4	50
4693C	1-1/2	50

Qual#	Size	Pkg
4694	8 x 1/2	50
4695	3/4	50
4696	1	50
4697	1-1/4	50
4697A	1-1/2	50
4697B	2	25

Qual#	Size	Pkg
4698	10 x 1/2	50
4699	3/4	50
4700	1	50
4701	1-1/4	50
4701A	1-1/2	25

Qual#	Size	Pkg
4704B	12 x 1/2	50
4702	3/4	50
4703	1	50
4704	1-1/4	25
4704A	1-1/2	25

Qual#	Size	Pkg
4705A	14 x 1/2	50
4705	3/4	50
4706	1	50
4705B	1-1/4	25
4707	1-1/2	25
4705C	2	25

### PHILLIPS FLAT HEAD



Qual#	Size	Pkg
4555	6 x 1/2	100
4556	1	100
4557	1-1/2	50

Qual#	Size	Pkg
4560	8 x 1/2	100
4561	3/4	100
4562	1	50
4563	1-1/2	50
4564	2	50
4565	2-1/2	50

Qual#	Size	Pkg
4568	10 x 1/2	100
4569	3/4	50
4570	1	50
4571	1-1/2	25
4572	2	25
4573	2-1/2	25

### ALL SCREWS ON THIS PAGE ARE:

- High strength
- Non-magnetic
- High corrosion resistance
- Accurately formed deep slotted head
- Clean sharp threads

# Stainless Steel 18-8 Sheet Metal Screws

## SLOTTED PAN HEAD



Qual#	Size	Pkg
4772	4 x 1/4	100
4773	3/8	100
4774	1/2	100
4775	3/4	100
4775A	1	100

Qual#	Size	Pkg
4418	6 x 1/4	100
4419	3/8	100
4420	1/2	100
4776	5/8	100
4421	3/4	100
4422	1	100
4777	1-1/4	100
4778	1-1/2	50

Qual#	Size	Pkg
4423	8 x 3/8	100
4424	1/2	100
4425	5/8	100
4426	3/4	100
4427	1	100
4428	1-1/4	50
4429	1-1/2	50

Qual#	Size	Pkg
4430	10 x 1/2	100
4431	5/8	100
4432	3/4	50
4433	1	50
4434	1-1/4	25
4435	1-1/2	25
4779	1-3/4	25
4780	2	25

Qual#	Size	Pkg
4436	12 x 1/2	50
4437	5/8	50
4438	3/4	50
4439	1	50
4440	1-1/4	25
4441	1-1/2	25
4781	1-3/4	25
4782	2	25
4783	2-1/2	25
4784	3	20

Qual#	Size	Pkg
4442	14 x 1/2	50
4443	5/8	50
4444	3/4	50
4445	1	50
4446	1-1/4	25
4447	1-1/2	25
4785	1-3/4	25
4787	2-1/2	20
4788	3	20

## SLOTTED ROUND HEAD



Qual#	Size	Pkg
4792	4 x 1/4	100
4793	3/8	100
4794	1/2	100
4794A	5/8	100
4795	3/4	100

Qual#	Size	Pkg
4796	6 x 3/8	100
4797	1/2	100
4798	5/8	100
4799	3/4	100
4800	1	100
4801	1-1/4	50
4802	1-1/2	50

Qual#	Size	Pkg	Qual#
4804	8 x 3/8	100	4858
4805	1/2	100	4859
4806	5/8	100	4860
4807	3/4	100	4861
4808	1	50	4862
4809	1-1/4	50	4863
4810	1-1/2	50	4864
4810A	2	50*, 25	4865*(50)
4810B	2-1/2	50*, 25	

Qual#	Size	Pkg	Qual#
4812	10x 1/2	100	4866
4813	5/8	50	4867
4814	3/4	50	4868
4815	1	50	4869
4816	1-1/4	25	4870
4817	1-1/2	25	4871
4818	1-3/4	25	4872
4819	2	25	4873
4819A	2-1/2	25	
4819B	3	25	

Qual#	Size	Pkg	Qual#
4821	12x 1/2	50	4875
4822	5/8	50	4876
4823	3/4	50	4877
4824	1	50	4878
4825	1-1/4	25	4879
4826	1-1/2	25	4880
4827	1-3/4	25	4881
4828	2	25	4882
4829	2-1/2	20	4883
4830	3	20	4884

## SLOTTED FLAT

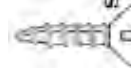

Qual#
4845
4846
4847
4848

Qual#
4850
4851
4852
4853
4854
4855
4856

Qual#
4858
4859
4860
4861
4862
4863
4864
4865*(50)

Qual#
4866
4867
4868
4869
4870
4871
4872
4873

Qual#
4875
4876
4877
4878
4879
4880
4881
4882
4883
4884

## SLOTTED ROUND HEAD



Qual#	Size	Pkg
4832	14x 1/2	50
4833	5/8	50
4834	3/4	50
4835	1	50

Qual#	Size	Pkg	Qual#
4836	1-1/4	25	4890
4837	1-1/2	25	4891
4838	1-3/4	25	4892
4839	2	25	4893
4840	2-1/2	20	4894
4841	3	20	4895

## SLOTTED FLAT

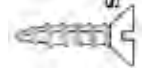

Qual#
4886
4887
4888
4889

### ALL SCREWS ON THIS PAGE ARE:

High strength, Non-magnetic, High corrosion resistance, Accurately formed deep slotted head

# Stainless Steel 18-8 Wood Screws

## SLOTTED FLAT HARD WOOD Class 2-A fit

Qual#	Size	Pkg
4900	6x 1/2	50
4901	5/8	50
4902	3/4	50
4903	1"	50
4904	1-1/4	50
4905	1-1/2	50

Qual#	Size	Pkg
4907	8x 1/2	50
4908	5/8	50
4909	3/4	50
4910	1"	50
4911	1-1/4	50
4912	1-1/2	50
4913	1-3/4	25
4914	2"	25

Qual#	Size	Pkg
4916	10x 3/4	25
4917	1"	25
4918	1-1/4	25
4919	1-1/2	25
4920	1-3/4	25
4921	2"	25
4922	2-1/2	25

Qual#	Size	Pkg
4924	12x 1"	25
4925	1-1/4	25
4926	1-1/2	25
4927	1-3/4	25
4928	2"	25
4929	2-1/2	25
4930	3"	25

# Stainless Steel 18-8 Machine Screws

## PHILLIPS

PAN			OVAL		FLAT
6-32 DIAMETER			Bx/100		
Qual#	Size	Pkg	Qual#	Qual#	
4708	3/4	100	3965	5000	
4709	1	100	3966	5001	
4710	1-1/4	50	3967	5002	
	1-1/2	100		5003	

8-32 DIAMETER				
Qual#	Size	Pkg	Qual#	Qual#
4711	3/4	100	3970	5004
4712	1	50	3971	5005
4713	1-1/4	50	3972	5006
	1-1/2	100		5007

10-32 DIAMETER				
Qual#	Size	Pkg	Qual#	Qual#
4714	3/4	50	3975	5008
4715	1	50	3976	5009
4716	1-1/4	50	3977	5010
4717	1-1/2	50	3978	5011

10-24 DIAMETER				
Qual#	Size	Pkg	Qual#	Qual#
4722	3/4	50	3981	5012
4723	1	50	3982	5013
4724	1-1/4	50	3983	5014
4725	1-1/2	50	3984	5015

1/4-20 DIAMETER				
Bx/50				
Qual#	Size	Pkg	Qual#	Qual#
4718	3/4	50	3987	5016
4719	1	25	3988	5017
4720	1-1/4	25	3989	5017-A
4721	1-1/2	25	3990	5018

5/16-18 DIAMETER				
Qual#	Size	Pkg	Qual#	Qual#
	3/4			5019
	1			5020
	1-1/4			
	1-1/2			5021



### ALL SCREWS ON THIS PAGE ARE:

- High strength
- Non-magnetic
- High corrosion resistance
- Accurately formed deep slotted head
- Class 2-A thread fit

## SLOTTED

ROUND					FLAT		OVAL	
4-40 DIAMETER								
Qual#	Qual#	Qual#	Size	Pkg				
4499	4448	4935	1/4	100				
4500	4449	4936	3/8	100				
4501	4450	4937	1/2	100				
4502	4451	4938	5/8	100				
4503	4452	4939	3/4	100				
4504	4453	4940	1	100				

6-32 DIAMETER				
Qual#	Qual#	Qual#	Size	Pkg
4505	4454	4942	1/4	100
4506	4455	4943	3/8	100
4507	4456	4944	1/2	100
4508	4457	4945	5/8	100
4509	4458	4946	3/4	100
4510	4459	4947	1	100
4511	4460	4948	1-1/4	50
4512	4461	4949	1-1/2	50
4512A	4461A	4949A	2	25

8-32 DIAMETER				
Qual#	Qual#	Qual#	Size	Pkg
4513	4462	4951	1/4	100
4514	4463	4952	3/8	100
4515	4464	4953	1/2	100
4516	4465	4954	5/8	100
4517	4466	4955	3/4	100
4518	4467	4956	1	50
4519	4468	4957	1-1/4	50
4520	4469	4958	1-1/2	50
4521	4470	4959	1-3/4	25
4522	4471	4960	2	25
		4960A	2-1/2	25

Slotted Flat



Slotted Oval



## MACHINE SCREW NUTS

Qual#	Size	Pkg
4549	4-40	100
4550	6-32	100
4551	8-32	100
4552	10-32	100
4553	10-24	100



## SLOTTED

ROUND					FLAT		OVAL	
10-32 DIAMETER								
Qual#	Qual#	Qual#	Size	Pkg				
4523	4472	4975	1/4	100				
4524	4473	4976	3/8	100				
4525	4474	4977	1/2	100				
4526	4475	4978	5/8	100				
4527	4476	4979	3/4	50				
4528	4477	4980	1	50				
4529	4478	4981	1-1/4	50				
4530	4479	4982	1-1/2	50				
	4480	4983	1-3/4	25				
4531	4481	4984	2	25				
	4481A		2-1/2	25				
	4481B		3	25				

10-24 DIAMETER				
Qual#	Qual#	Qual#	Size	Pkg
4532	4482	4962	1/4	*50, 100
4533	4483	4963	3/8	*50, 100
4534	4484	4964	1/2	*50, 100
4535	4485*	4966*	3/4	*50, 100
4536	4486	4967	1	*50, 100
4537	4487	4968	1-1/4	*25, 50
4538	4488	4969	1-1/2	*25, 50
4539	4489*	4970*	1-3/4	*25, 50
4540	4490	4971	2	*25, 50
4540B	4490A		2-1/2	25
	4490B		3	25

1/4-20 DIAMETER				
Qual#	Qual#	Qual#	Size	Pkg
4541	4491	4988	3/8	50
4542	4492	4989	1/2	50
4543	4493	4991	3/4	50
4544	4494	4992	1	25
4545	4495	4993	1-1/4	25
4546	4496	4994	1-1/2	25
4547	4497	4995	1-3/4	25
4548	4498	4996	2	25
4548A	4498A		2-1/2	25
4548B	4498B		3	25

Slotted Round

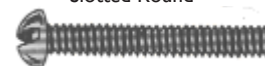

# Chain & Chain Products

## GRADE 40 HIGH TEST

Grade 40 Chain features both high tensile strength and resistance to wear needed by modern hauling and heavy-duty trucking, farm and construction firms. Working load limits exceed those of ordinary low carbon or general utility chain.

**MATERIAL** - Carbon Steel

**ATTACHMENTS** - Can be supplied in assemblies with any standard chain attachments such as rings, slip hooks, grab hooks, eyebolts, snaps, and enlarged links. Can also be finished with special attachments for which detailed prints should be furnished with inquiry or order.

**TEST CERTIFICATE** - furnished on request.



### SPECIFICATIONS

Trade Size	Wire Dia.	Inside Dimensions		Working Load	Wt. Per 100
Inch.	Inch.	Lgth Inch.	W Inch.	Limit Lbs. **	Ft. Lbs
1/4	.281	1.19	.40	2,600	65.92
5/16	.343	1.24	.46	3,900	103.81
3/8	.406	1.33	.57	5,400	151.75
7/16	.468	1.72	.75	7,200	261.17
1/2	.531	1.59	.74	9,200	264
5/8	.656	2.12	.82	14,000	392.20
3/4	.781	2.65	1.02	19,750	548.08

### REELS

Trade Size	Gross Wt.	FT. Per	Qual#
Inch.	Per Reel Lbs	Reel	
1/4	58	75	60000
5/16	79	70	60001
3/8	64	40	60002
7/16	-	-	-
1/2	-	-	-
5/8	-	-	-
3/4	-	-	-

### PAILS

Gross Wt.	FT. Per	Qual#
Per Pail	Pail	
100	134	60003
100	90	60004
100	64	60005
-	-	-
-	-	-
-	-	-
-	-	-

### SPECIFICATIONS

Trade Size	Wire Dia.	Inside Dimensions		Working Load	Wt. Per
Inch.	Inch.	Lgth Inch.	W Inch.	Limit Lbs. **	100 Ft. Lbs
1/4	.281	1.19	.40	2,600	65.92
5/16	.343	1.24	.46	3,900	103.81
3/8	.406	1.33	.57	5,400	151.75
7/16	.468	1.72	.75	7,200	261.17
1/2	.531	1.59	.74	9,200	264
5/8	.656	2.12	.82	14,000	392.20
3/4	.781	2.65	1.02	19,750	548.08

### HALF DRUM

Trade Size	FT Per	Qual#
Inch.	1/2 Drum	
1/4	400	60006
5/16	275	60007
3/8	200	60008
7/16		
1/2	100	60010
5/8	75	60011
3/4	50	60012

### FULL DRUM

Ft. Per	Qual#
Drum	
800	60019
550	60020
400	60021
300	60022
200	60023
150	60024
100	60025

**\*\*Working load limit must not be exceeded**

**Not to be used for lifting or hoisting applications**

## GRADE 70 TRANSPORT CHAIN

Grade 70 is extremely strong for its light weight and is used primarily for load binding in the transportation industry. However, it is also used extensively on farms, in lumbering, towing and construction.. Grade 70's high strength to weight ratio is achieved due to the Boron Manganese Steel from which it is fabricated. It resists wear because of its exceptional hardness properties.

**FINISH** - Black lacquered.

**ATTACHMENTS** - Can be supplied in assemblies with forged clevis grab hooks on each end and other attachments as reg'd. Grade 70 is approved by the Department of Transportation for truck tie-down use.

**TEST CERTIFICATE** - All Grade 70 chain is proof tested with certificates furnished on request.



### SPECIFICATIONS

Trade Size	Wire Dia.	Inside Dimensions		Working Load	Minimum Ultimate	Wt. Per
Inch.	Inch.	Lgth Inch.	W Inch.	Limit Lbs. **	Strength Lbs. *	100 Ft. Lbs
1/4	.276	1.19	.4	3,150	12,600	63.02
5/16	.334	1.24	.46	4,700	18,800	95.57
3/8	.394	1.33	.57	6,600	26,400	141.34
1/2	.519	1.72	.75	11,300	45,200	248.35

### HALF DRUM

Trade Size	FT Per	Qual#
Inch.	1/2 Drum	
1/4	400	60026
5/16	275	60027
3/8	200	60028
1/2	100	60029







**\*\*Working load limit must not be exceeded**

Not to be used for lifting or hoisting applications

\*The values for minimum ultimate strength shown here should only be used for calculating the number of tie-down chains required in compliance with D.O.T. Reg. 393.102b

## Chain & Chain Products

### CLEVIS HOOKS

Size	Working Load Limit	GRADE 43 GRAB & SLIP HOOK Qual#	GRADE 43 SAFETY HOOK Qual#	GRADE 70 GRAB HOOK Qual#	GRADE 80 ALLOY GRAB HOOK Qual#	SLIP HOOK For use w/Gr 40 High Test Chain Qual#	EYE TYPE GRAP HOOK For use w/Gr 30 Proof Coil Qual#	EYE TYPE SLIP HOOK For use w/Gr 30 Proof Coil Qual#
1/4	1,250						60050	60055
1/4	2,600	60040				60045		
5/16	1,900						60051	600565
5/16	3,900	60041				60046		
5/16	4,700			60039				
3/8	2,650						60052	60057
3/8	5,400	60042	60037			60047		
3/8	6,600			60049				
1/2	4,500						60053	60058
1/2	9,200	60043	60036			60048		
1/2	12,000				60038			
								

### ANCHOR SHACKLES WITH SCREW PINS

Qual#	Size	Pin Diam.	BTWN Eyes	Load Limit	Pkg
60086	1/4	5/16	15/32	1000	5
60087	5/16	3/8	17/32	1500	5
60088	3/8	7/16	21/32	2000	5
60089	1/2	5/8	13/16	4000	1
60090	5/8	3/4	1-1/16	6500	1
60091	3/4	7/8	1-1/4	10,000	1
60093	7/8			13,000	1
60092	1"	1-1/8	1-11/16	17,000	1
60094	1-1/4			24,000	1

Shackles meet strength requirements as shown in Federal Specifications R-R-C-271B



### WIRE ROPE CLIPS

Qual#	Size	Pkg
60095	1/8	10
60096	3/16	10
60097	1/4	10
60098	5/16	10
60099	3/8	10
60100	1/2	5
60101	5/8	5
60102	3/4	5



### QUICK LINKS

Qual#	Size	Work Load	Pkg
60080	1/8	220	10
60081	3/16	610	10
60082	1/4	880	10
60083	5/16	1540	10
60084	3/8	1980	5
60085	1/2	3300	5

Attaches accessories quickly without tools. Use only with chain of equal or lower working load limit



### WIRE ROPE THIMBLES

Qual#	Size	Overall Lgth	Pkg
60105	1/8	1-3/4	10
60106	3/16	1-3/4	10
60107	1/4	1-3/4	10
60108	5/16	2-1/4	10
60109	3/8	2-1/4	10
60110	1/2	2-1/2	10
60111	5/8	2-7/8	5
60112	3/4	3-5/8	5

Thimble made from heavy steel





## Chain & Chain Products

### COLD SHUTS Pkg 10

Qual#	Size	Work Load
60060	3/16	340
60061	1/4	750
60062	5/16	1250
60063	3/8	1900
60064	1/2	4090

It is recommended that the next larger Cold Shut be used than the diameter of Gr 30 chain



### CONNECTING LINKS Pkg 5

Qual#	Size	Work Load
60072	3/16	800
60073	1/4	1325
60074	5/16	1950
60075	3/8	2750
60076	1/2	4750

Drop forged for temporary or permanent connection of attachments to chain. Links provided with interlocking lugs and rivets. For permanent connections, the rivets must be headed into the countersunk holes.



### LAP LINK CONNECTORS Pkg 25

For use with low carbon chain only

Qual#	Size	Work Load
60065	7/32 x 1-1/4	220
60066	1/4 x 1-1/4	400
60067	5/16 x 1-5/8	700
60068	3/8 x 2	1500

Cold forged from rolled steel and machine formed. Laps are long and tapering, making a smooth assembly.

Link must be closed before using.



### MID LINKS

(Double Clevis Link) Pkg 2

Qual#	Size	Work Load
60069	1/4 - 5/16	4700
60070	3/8	6600
60071	7/16 - 1/2	11,300

For use with grades 30, 40, and 70 chain Hot Forged.

- Heat Treated
- Tempered
- Bright Zinc

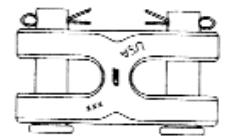

## Load Binders

### HIGH STRENGTH TRANSPORTATION LOAD BINDER

Binder#	CHAIN			BINDER		
	Size/Grade	Working Load Limit Lbs	Lever Lgth Inch	Take Up inches	Wt. Ea. Lbs	Min. Breaking Strength
BX-600	5/16" Gr70	4700	12-1/2	4-1/2	10-3/8	19,000
BX-600	3/8" Gr40	5400	12-12	4-1/2	10-3/8	19,000
BXR-300	5/16" Gr70	5400	16	4-1/4	9-1/2	19,000
BXR-300	3/8" Gr43	5400	16	4-1/4	9-1/2	19,000
BXR-310	5/16" Gr70	4700	15-3/4	8	9-1/2	19,000
BXR-310	3/8" Gr40	5400	15-3/4	8	9-1/2	19,000
BXR-410	3/8" Gr70	6600	15-3/4	8	9-1/2	19,000
BXR-410	1/2" Gr40	9200	15-3/4	8	11	28,000

This tough Binder swivels 360° at both ends, toggles away from the load and allows easier release of the handle under all load conditions. For all heavy duty interstate transport users. Meets all D.O.T. regulations.

### BXR-310, BXR-410 RATCHET



BX-600



BX-272A



### FARM & INDUSTRIAL LOAD BINDER

Binder#	CHAIN			BINDER		
	Size/Grade	Working Load Limit Lbs	Lever Lgth Inch	Take Up inches	Wt. Ea. Lbs	Min. Breaking Strength
BX-272A	5/16" Gr30	1900	21	4-1/2	6-1/2	11,000
BX-272A	3/8" Gr30	2650	21	4-1/2	6-1/2	11,000

Moderate cost binders with plenty of toughness forged in, easily capable of tying down a load of hay, grain or a large piece of equipment or machinery.

### MINI-LOAD BINDER

Binder#	CHAIN			BINDER		
	Size/Grade	Working Load Limit Lbs	Lever Lgth Inch	Take Up inches	Wt. Ea. Lbs	Min. Breaking Strength
BX-270	3/16" Gr30	750	7-12	2-3/4	1-1/4	1250

A versatile light weight binder designed for use on truck racks, boat trailers, ski mobiles and RV of all kinds. One hook swivels 360°

### NOTES:

- Working load limits are those of the maximum chain size and grade normally used with the load binders.
- Working load limits of American Chain meet the new National Association of Chain Manufacturers Specifications and the Minimum Breaking Strengths of the Load Binders are in compliance with the Dept. of Transportation Regulations.
- For safety reasons, extensions should not be added to load binder handles. Not to be used for lifting or hoisting applications.

## Brushes



3/8" **TIN HANDLE ACID BRUSHES**  
Qual #: M-7 Pkg 36  
Filled with stiff Black Horsehair

### STEEL SCRATCH BRUSHES



14" **CURVED HANDLE** (molded)  
Qual #: 20131  
Wood-grain molded block with 3x19 rows of tempered steel wire. 1-1/8" trim. Looks like wood but is easier on the hands.



10" **SHOE HANDLE** (molded).  
Qual #: 20132 Pkg 4  
Heavy-duty shoe handle style wire scratch. 4x16 rows tempered steel wire on wood-grain molded block. 1-1/4" trim

Qual #: 60213 Shoe Handle w/scrapper avail.

### PARTS CLEANING BRUSHES



**NYLON BRUSH**  
Qual #: 20130  
Crimped Bristle Pkg 4



**PIG BRISTLE & HORSEHAIR**  
Qual #: 20133  
Will not collapse in water; oil set in rubber or gasoline. Pkg 2



**STAINLESS STEEL JR. SIZE**  
Qual #: 20129  
SS bristles in a plastic grip handle Pkg 5

### PAINT BRUSHES



Qual#	Width	Size	Trim
60235	1"	9"	2-3/8
60236	2"	10"	2-5/8
60237	3"	10"	3"
60238	4"	11"	3"

### WIRE END & WIRE CUP BRUSHES

**3" CIRCULAR**  
Qual #: 20160



**1" SOLID END TYPE**  
Qual #: 20161



**1-1/2 CUP TYPE**  
Qual #: 20162



**6" H.D. CUP 5/8-11 THREAD**  
Qual #: 20163



**1-1/8 ALL KNOTTED END**  
Qual #: 20165

For use with portable air and electric tools to remove carbon deposits, rust, scale or paint from hard to reach areas. All shanks are 1/4" diameter. All wire is crimped carbon steel.



### DECK SCRUB BUSH

Qual #: 60209  
Stiff Palmyra 10 x 2-7/8, HANDLES NOT INCLUDED,



**3-WAY SNOW BRUSH. PVC**  
Qual #: 60200  
one piece scraper & squeegee. 24" handle with row of poly bristles 8-1/2" long



**2-WAY SNOW BRUSH**  
Qual #: 60203  
Same as above except without brush.



**CAR WHISK BROOM**  
Qual #: 60212  
Dark Red Palmetto Broom in 9" size. Good for carpeted or texture surfaces.

### OUTDOOR GARAGE BROOMS



24" **PALMYRA**  
Qual #: 60218  
Popular Heavy-duty Brown Palmyra fiber, 4" trim. HANDLES NOT INCLUDED.



24" **ZEPHYR SYNTHETIC**  
Qual #: 60219  
Dual-fill broom has stiff Br. Alglyl center with border of light gauge Alglyl. HANDLES NOT INCLUDED.

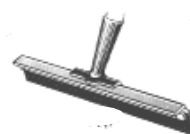

**24" FLOOR SQUEEGEE**  
Qual #: 60223  
Heavy-duty cadmium plated steel frame & cast aluminum handle sockets. Rubber blades 2" x 1/4" thick. HANDLES NOT INCLUDED.

**CAUTION** Any cutting tool may break or shatter under improper use. Government regulations require use of safety glasses and other appropriate equipment in area of use.

# Hole Saws, Arbors and Accessories

## ARBORS

Qual#	Fits Hole Saw	Shank Type	Chuck Size	
			Inches	mm
AM-30001 (1L)	9L-19L	Hex	1/2	13
AM-30002 (2L)	20L-96L	Hex	1/2	13
AM-30003 (3L)				
AM-30004 (4L)	9L-19L	Round	1/4	6
AM-30005 (5L)	9L-19L	Hex	3/8	10
AM-30006 (6L)	20L-96L	Hex	3/8	10

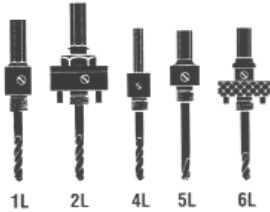

## ACCESSORIES

Qual #:	Accessory	Chuck Size		Fits Arbor #
		Inches	mm	
AM-30850	Pilot Drill	1/4	6	1L,2L,4L
AM-30857	Arbor Adaptor			1L,4L,5L
AM-30847	12"/300mm Extension	1/2	13	1L,2L
AM-30846	5-1/2"/140mm Extension	1/2	13	1L,2L



Adaptor



Pilot Drill



Extensions 5-1/2", 10", 12"

## HOLE SAWS

Qual#	Diameter		Pipe Tap Inches(mm)	Pipe Entr. Inches(mm)	Use Arbor #
	Inches	mm			
AM-30009	9/16	14			1L,4L,5L
AM-30010	5/8	16			1L,4L,5L
AM-30011	11/16	17			1L,4L,5L
AM-30012	3/4	19	1/2 (13)	3/8 (10)	1L,4L,5L
AM-30013	13/16	21			1L,4L,5L
AM-30014	7/8	22	3/4 (19)	1/2 (13)	1L,4L,5L
AM-30015	15/16	24			1L,4L,5L
AM-30016	1	25			1L,4L,5L
AM-30017	1-1/16	27			1L,4L,5L
AM-30018	1-1/8	29	1 (25)	3/4 (19)	1L,4L,5L
AM-30019	1-3/16	30			1L,4L,5L
AM-30020	1-1/4	32			2L,6L
AM-30021	1-5/16	33			2L,6L
AM-30845	1-7/32				
AM-30022	1-3/8	35		1 (25)	2L,6L
AM-30023	1-7/16	37			2L,6L
AM-30024	1-1/2	38	1-1/4 (32)		2L,6L
AM-30025	1-9/16	40			2L,6L
AM-30026	1-5/8	41			2L,6L
AM-30027	1-11/16	43			2L,6L
AM-30028	1-3/4	44	1-1/2 (38)	1-1/4(32)	2L,6L
AM-30029	1-13/16	46			2L,6L
AM-30030	1-7/8	48			2L,6L
AM-30032	2	51		1-1/2(38)	2L,6L
AM-30033	2-1/16	52			2L,6L
AM-30034	2-1/8	54			2L,6L



Hole Saw

Qual#	Diameter		Pipe Tap Inches (mm)	Pipe Entr. Inches(mm)	Use Arbor#
	Inches	mm			
AM-30036	2-1/4	57	2 (51)		2L,6L
AM-30037	2-5/16				
AM-30038	2-3/8	60			2L,6L
AM-30040	2-1/2	64		2 (51)	2L,6L
AM-30041	2-9/16	65			2L,6L
AM-30042	2-5/8	67	2-1/2 (64)		2L,6L
AM-30044	2-3/4	70			2L,6L
AM-30046	2-7/8	73			2L,6L
AM-30048	3	76		2-1/2 (64)	2L,6L
AM-30050	3-1/8	79			2L,6L
AM-30052	3-1/4	83	3 (76)		2L,6L
AM-30054	3-3/8	86			2L,6L
AM-30056	3-1/2	90			2L,6L
AM-30058	3-5/8	92		3 (76)	2L,6L
AM-30060	3-3/4	95	3-1/2 (90)		2L,6L
AM-30062	3-7/8				
AM-30064	4	102			2L,6L
AM-30066	4-1/8	105		3-1/2 (90)	2L,6L
AM-30068	4-1/4	108	4 (102)		2L,6L
AM-30070	4-3/8				
AM-30072	4-1/2	115			2L,6L
AM-30076	4-3/4	121	4-1/2 (115)	4 (102)	2L,6L
AM-30080	5	127			2L,6L
AM-30088	5-1/2	140			2L,6L
AM-30096	6	152			2L,6L

## HOLE SAW KITS AVAILABLE

Qual #: AM-600L 6 sizes most commonly used for pipe tap

Qual #: AM-600P 6 sizes commonly used for pipe & conduit

Qual #: AM-1200L 12 popular sizes 5/8"-3"

## JIG SAW BLADES

Qual#	Lgth x width x thickness		Teeth / inch	Uses
	Inches	MM		
AM-20610	3 x 3/8 x .037	75 x 10 x .9	14	Metal over 1/4" (6.4mm) Thick
AM-20611	3 x 3/8 x .035	75 x 10 x .9	18	Metal over 1/8" (3.2mm) Thick, general purpose
AM-20612	3 x 3/8 x .037	75 x 10 x .9	24	Thin metal, plastic, polys, paneling
AM-20620	4-1/2 x 3/8 x .050	115 x 10 x 1.3	6	Wood, fast cut, rough
AM-20622	4-1/2 x 3/8 x .050	115 x 10 x 1.3	10	Wood, nail-embedded
AM-20628	3-1/2 x 1-1/8 x .050	90 x 30 x 1.3	6/10	Wood, flush cut
AM-20638	3-1/2 x 3/8 x .037	90 x 10 x .9	10/14	Wood/Metal, All purpose
AM-20690	3-1/2 x 1/4 x .050	90 x 6 x 1.3	10	Wood: Contour/scroll

## 3 PIECE ASST

Qual #: AM-20602 with 1 ea. of 20611, 20620, 20690





















## 5 PIECE ASST

Qual #: AM-20601 with 1 ea. of 20610, 20611, 20612, 20620, 20622 Both packed in vinyl pouch.

**BAYONET BLADES**

Qual #	Lgth x width x thickness		Teeth / inch	Uses
	Inches	MM		
AM-20715	1-3/4 x 1/4 x .032	45 x 6 x .8	10	Wood, nail-embedded
AM-20716	1-3/4 x 1/4 x .032	45 x 6 x .8	14	Metal over 1/4" (6.4mm) Thick
AM-20717	1-3/4 x 1/4 x .032	45 x 6 x .8	18	Metal over 1/8" (3.2mm) Thick, general purpose
AM-20718	1-3/4 x 1/4 x .032	45 x 6 x .8	24	Thin metal, plastic, polys, paneling
AM-20725	3 x 3/8 x .032	75 x 10 x .8	6	Wood, fast cut, rough
AM-20727	3 x 3/8 x .032	75 x 10 x .8	10	Wood, nail-embedded
AM-20728	3 x 3/8 x .032	75 x 10 x .8	14	Metal over 1/4" (6.4mm) Thick
AM-20730	3 x 3/8 x .032	75 x 10 x .8	18	Metal over 1/8" (3.2mm) Thick, general purpose

**SAWS ALL BLADES**

Qual #	Lgth x width x thickness		Teeth / inch	Shape	Uses
	Inches	MM			
AM-20502	Assortment of Saws All Blades				
AM-20520	3 x 1/4 x .032	75 x 6 x .8	14		Irregular contours
AM-20521	3 x 1/4 x .032	75 x 6 x .8	18		Contour- metals under 1/8" (3.2mm)
AM-20550	4 x 3/4 x .035	100 x 20 x .9	14		Heavy gage metal, rubber & fiber
AM-20552 AM-20571	4 x 3/4 x .035	100 x 20 x .9	18		Heavy gage metal, conduit & tubing
AM-20554	4 x 3/4 x .035	100 x 20 x .9	24		Metal & galvanized pipe 18 gage & under
AM-20556	6 x 7/16 x .050	150 x 11 x 1.3	6		Wood contours
AM-20560	6 x 3/4 x .035	150 x 20 x .9	6		Wood, all composition material
AM-20562	6 x 3/4 x .035	150 x 20 x .9	10		Wood, composition, plastic, cast aluminum, light non-ferrous metals
AM-20573	6 x 3/4 x .035	150 x 20 x .9	14		Metal & galvanized pipe 18 gage & above
AM-20570	6 x 3/4 x .035	150 x 20 x .9	6		Plaster, plaster board
AM-20564	6 x 3/4 x .035	150 x 20 x .9	14		Heavy gage metal, rubber & fiber
AM-20566	6 x 3/4 x .035	150 x 20 x .9	18		Heavy gage metal, conduit & tubing
AM-20568	6 x 3/4 x .035	150 x 20 x .9	24		Metal & galvanized pipe 18 gage & under
AM-20572 AM-20573-W	6 x 3/4 x .050	150 x 20 x 1.3	6		Rough work in wood
AM-20575	6 x 3/4 x .035	150 x 20 x .9	4		Nail free woods
AM-20569	8 x 3/4 x .035	200 x 20 x .9	10		Wood, composition, plastic, cast aluminum, light non-ferrous metals
AM-20580	8 x 3/4 x .035	200 x 20 x .9	10/14		Wood, composition, plastic, cast aluminum, light non-ferrous metals
AM-20569-A	8 x 3/4 x .035	200 x 20 x .9	14		Metal & galvanized pipe 18 gage & above
AM-20582	9 x 3/4 x 1.3	225 x 20x.050	6		Rough work in wood
AM-20569-W	9 x 3/4 x .050	225 x 20 x 1.3	6		Rough work in wood
AM-20585 AM-20574-W	12 x 3/4 x .050	300 x 20 x 1.3	6		Rough work in wood
AM-20583	12 x 3/4 x .050	300 x 20 x 1.3	10/14		All woods, plastic, & cast aluminum
AM-20574	12 x 3/4 x .035	300 x 20 x .9	14		Metal & galvanized pipe 18 gage & above

## BI-METAL AIR SAW BLADES

Qual #	Length x Width x Thickness Inches	MM	Teeth / inch	Shape
AM-314TO5	3 x 1/2 x .025	75 x 12.7 x .6	14	
AM-318TO5	3 x 1/2 x .025	75 x 12.7 x .6	18	
AM-324TO5	3 x 1/2 x .025	75 x 12.7 x .6	24	
AM-332TO5	3 x 1/2 x .025	75 x 12.7 x .6	32	
AM-424TO5	4 x	100 x	24	

### Uses

Specially designed for use in pneumatic saws. The fine teeth are good for cutting metal. Used in fabricating shops and auto-body/muffler shops

## HACK SAW BLADES & HANDLES

Qual #	Length x Width x Thickness Inches	MM	Teeth / inch
M-594-X	12 x 1/2 x .025	300 x 12.7 x .6	18
M-595-X	12 x 1/2 x .025	300 x 12.7 x .6	24
M-596-X	12 x 1/2 x .025	300 x 12.7 x .6	32



## HACK SAW FRAME

Qual #: M-593

Heavy-duty Aluminum Handle, Rectangular steel crossbar, Blade storage. Converts to Jab or Compass Saw, Permanent Hardened / Serrated Blade Holding Pins



## HANDY HACK

Qual #: AM-20928

Cuts flush. Includes Bi-Metal 10" (250mm) Blade. Blade reverses.



## MISCELLANEOUS BLADES

Qual #: 20453 Bx 100  
#9 General Purpose Metal  
Razor Blades

Qual #: 41575 Bx 100  
Plastic Razor Blades  
Ideal for removing stickers from  
plastic-coated windshields

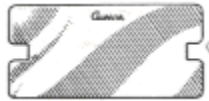
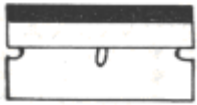

## UTILITY KNIFE

Qual #: M-599

Steel construction, enamel finish. Blade retracts into handle when not in use. Comes with one heavy duty blade stored in handle.

Qual #: M-600

10 Replacement Blades

Qual #: M-600-L

100 Replacement Blades



## CHOP SAW BLADES

For metal cutting in low horsepower chop saws. The following are for general purpose metal

Qual #	Lgth x W x Thck
M-45	12 x 3/32 x 1
M-46	14 x 3/32 x 1



## HUMMER ABRASIVE WHEEL

Qual #: M-22-4

4" wheel w/ 3/8" arbor hole  
For cut-off or grinding in high  
speed air or electric die grinders



## Hummer® Abrasive Wheels

(Type I Resin Bonded Wheels)

These specially formulated resin bonded wheels remove metal quickly, are long lasting and make clean cuts. They are the popular choice for high speed air or electric die grinders for both cut-off and grinding applications. You'll find them anywhere metal has to be removed, from small fabrication shops, to giant automotive and aircraft assembly plants.

- Aluminum Oxide Grain and double fiberglass reinforcement resist breakage and insure safer operation.
- Resin bond provides fast cutting and grinding.
- Special Morse formulations mean longer life and cleaner cuts.

**PACKAGING:** All 1/8" & thinner wheels are 25 per box.  
All 1/4" & thicker wheels are 10 per box.



## PRO\* CUT FILE BLADES & HOLDER

Pro\*Cut is specifically engineered to shape plastic body filler, freshly cured or hard a steel.

Qual #	Type	Pkg
80677	10" Holder w/flat blade	1
80606	14" Flat blade	5
80619	14" Half Round Blade	5
80674	14 Holder w/flat blade	1



# 3M

## Adhesive Products

### SCOTCHMATE HOOK AND LOOP FASTENING SYSTEM

Premium performance adhesive system. Includes twelve 1" x 12" mated strips per box.

Qual #: MMM-06480 6 Bx/case  
Qual #: MMM-06480-1 Box



### OIL SPILL AND FLUID RECOVERY SORBENTS

Specially treated to absorb most shop liquids including motor oils, transmission fluids, gear oils and anti-freeze solutions

Qual #: MMM-07164 Pad, 15-1/2" x 20 x 1/2 100/ Box  
Qual #: MMM-07167 Roll, 38" x 150' 1

### GENERAL PURPOSE ADHESIVE CLEANER

Quickly removes waxes, road tars, grease, oil and similar materials Quart cans cs/6 (-1) ea

Qual #: MMM-08984 (-1)



### MULTI-PORT FUEL INJECTOR CLEANER

Quickly removes varnish, gum and other deposits from fuel injectors cs/6 (-1)/ ea

Qual #: MMM-08912 (-1)

### WOOD GRAIN & STRIPE REMOVER

For removing wood grain vinyl and vinyl stripes from acrylic enamel surfaces Aerosol cs/6 (-1)/ ea

Qual #: MMM-08907 (-1)

### WOOD GRAIN & STRIPE ADHESIVE REMOVER

Cleans off adhesive residue after wood grain vinyl or vinyl stripes have been removed Aerosol cs/6 (-1)/ ea

Qual #: MMM-08908 (-1)

### PLASTIC & EMBLEM ADHESIVE

- Clear  
Used for bonding metal emblems, rigid plastic parts, taillight lenses and vinyl trim strips.

Qual #: MMM-08061 CS/ 12 (-1) / 1

### FAST TACK TRIM ADHESIVE

- Light Amber  
Used for bonding trim fabric. Especially good for headliners.

Qual #: MMM-08031 CS/ 12 (-1) / 1

## Sealers

### SUPER FAST URETHANE SEALER

Black  
A rapid-curing adhesive/sealant intended for all flush mounted and bonded windshield or backlite replacements. Cartridges Cs/12  
Qual #: MMM-08609

### SUPER SILICONE SEALANT

Rapid-curing adhesive/sealant formulated to solve repair and maintenance problems.  
Tube cs/12 (-1)/ ea  
Qual #: MMM-08661 (-1) Clear  
Qual #: MMM-08662 (-1) Black

### AUTOMOTIVE JOINT & SEAM SEALER - Black

Firm-setting, flexible sealer for interior and exterior auto seams. Can be tooled and smoothed. Cartridges cs/12  
Qual #: MMM-08648

### WINDOW-WELD SEALER

Black  
A one-part polysulfide adhesive sealant for use in the replacement of "bonded" windshields & backlites.  
Cartridges cs/12 (-1) / ea  
Qual #: MMM-08606 (-1)

### HEAVY DRIP-CHEK SEALER

Gray  
Heavy-based sealer especially designed for use on vertical seams. Excellent adhesion to metal, paint, glass, rubber. Resists gas and oil. Tubes 12/cs (-1)/ea  
Qual #: MMM-08531 (-1)

### ROCKER SCHUTZ

Beige  
A fast-drying, paintable, chip-resistant coating for use on motor vehicles that resists weathering.  
Quart can cs/6 (-1)  
Qual #: MMM-08874 (-1)

### BODY SCHUTZ RUBBERIZED COATING

Black  
Rubberized, protective coating developed primarily for use as a sound deadener, protective coating and underseal. Quart can cs/6 (-1)/ ea  
Qual #: MMM-08864 (-1)

### STRIP-CALK

Black  
Soft, non-hardening caulking material in one-foot lengths for use in all types of seams, joints and openings. Excellent adhesion to metal, paint, glass, rubber. Weatherproof. May be painted immediately. Bx of 60  
Qual #: MMM-08578

### WINDOW-WELD RIBBON SEALER

Black  
One kit or one 15 ft. roll is sufficient material to replace one windshield or backlite.  
Cs/12 kits (-1) ea kit

Qual #: MMM-08611 5/16" x 15' kit  
Qual #: MMM-08612 3/8" x 15' kit

### CARTRIDGE APPLICATOR GUN

1/10 gal Cartridge Gun to use with Auto Bedding & Glazing compound & Window Weld Sealer.

Qual #: MMM-08992 each

### AUTO BEDDING & GLAZING COMPOUND

Black  
Non-hardening, pliable, water-resistant, medium-bodied sealer for sealing auto seams and between windshield rubber and car body. Cartridges Cs/12 (-1) / ea

Qual #: MMM-08509(-1)

### SUPER WEATHERSTRIP ADHESIVE

Bonds all types of gaskets to painted or unpainted metal surfaces. Adhesive stays flexible, does not dry out or become hard. Waterproof. Resists oil, grease and solvents cs/12 (-1) / 1 (-6) / 6

Qual # Color  
MMM-08001 Yellow  
MMM-08001-1 Yellow  
MMM-08001-6 Yellow  
MMM-08008 Black  
MMM-08008-1 Black  
MMM-08008-6 Black



### WEATHERSTRIP ADHESIVE

Black  
Fast-drying black adhesive used for bonding & sealing weather-stripping including EPDM type. cs/12 (-1) / 1 (-6) / 6

Qual #: MMM-08011  
Qual #: MMM-08011-1  
Qual #: MMM-08011-6



### SUPER TRIM ADHESIVE SPRAY

Yellow

A contact adhesive designed for bonding vinyl tops, heavyweight headliners and hood silencer pads where high strength and heat resistance are needed cs/6 (-1) / 1

Qual #: MMM-08090 (-1)



### GENERAL TRIM ADHESIVE SPRAY

Clear

Used for bonding automotive materials (carpeting, fabrics, plastics to metal and other surfaces. Not recommended for bonding polystyrene foam use 08074 instead. cs/6 (-1) / 1

Qual #: MMM-08088





## Job-Packed Abrasives & Accessories

### EMERY CLOTH

9x11 Sheets used for general purpose metal sanding, light clean-up work and rust removal

M-9	Emery- fine	50 sheets/ sleeve
M-10	Emery-med	50 sheets/ sleeve
M-10C	Emery-coarse	50 sheets/ sleeve



### EMERY CLOTH UTILITY ROLLS

1"x50 yard rolls used for smoothing rough spots, deburring & cleaning metal surfaces

M-3-320	320 grade	Each / roll
M-3-280	280g grade	Each / roll
M-3-180	180 grade	Each / roll



### DRY SANDPAPER SHEETS

9" x 11" Dry sanding only on machine or by hand. Open coat resists loading. Good for shaping & finishing plastic filler

Qual #	GRADE	# SHEETS/ sleeve
MMM-02104	180A	100
MMM-02112	150C	100
MMM-02113	120C	100
MMM-02114	100C	100
MMM-02115	80D	50

### 3-2/3" x 9"

M-11-100	100C	100
M-11-80	80D	100

### WET OR DRY PAPER SHEETS

9" x 11" Use with water or dry for sanding old finishes, fine featheredging & surface sanding

Qual #	GRADE	# SHEETS/ sleeve
MMM-02000	600A	50
MMM-02001	500A	50
MMM-02004	320A	50
MMM-02014	180C	50
MMM-02015	150C	50
MMM-02018	80C	50

### SCOTCH-BRITE GENERAL PUPOSE PAD

6" x 9"  
For scuffing before applying paint & primer-surfacer Made of nylon web. Reuseable .

Qual #: MMM-07447  
20/Bx



### ROLOC BRISTLE DISC 10/bx

Super tough plastic bristle brush, embedded with abrasive. Ideal tool to replace scrapers, wire wheels & chemical gasket stripper. Use green on steel parts & yellow on aluminum parts

Qual #:		Grade
MMM-07524	2" green	50
MMM-07525	2" yellow	80
MMM-07526	3" green	50
MMM-07527	3" yellow	80
MMM-07528	2" white	120
MMM-07529	3" white	120
MMM-07530	1" green	50



### WET OR DRY FABRICUT ROLLS

1-1/2" x25 yds  
Made from a flexible, synthetic open mesh screen-type backing. Coated on both sides with aluminum oxide mineral. Great for cleaning rusted surfaces. Can be used with water, oil or axle grease without loading

Qual #	Grade	Roll /cs
MMM-05072	120	5



### IMPERIAL WET OR DRY PAPER SHEETS

9" x 11"  
Premium, aluminum oxide mineral, an improved paper backing and an optimized construction. Improved rate of cut, increased abrasive life, increased flexibility, with consistent finish.

Qual #	GRADE	# SHEETS/ sleeve
MMM-02040	P320	50
MMM-02043	P220	50

### SCOTCH-BRITE SURFACE CONDITIONING DISCS

For STEEL Parts

Qual#	Grade/Color	Size	Pkg
M-13-25	Med/ Maroon	2"	25
M-15	Coarse/Brown	2"	25
M-12	Med/ Maroon	4"	10
M-29	Coarse/Brown	4"	10



### SCOTCH-BRITE ROLOC SURFACE CONDITIONING DISCS

For STEEL Parts

Qual#	Grade/Color	Size	Pkg
M-26	Coarse/Brown	2"	25
M-27	Med/ Maroon	2"	25
M-28	Coarse/Brown	3"	25
M-24	Coarse/Brown	4"	10



### SCOTCH-BRITE DISC PAD

Qual #: M-17 2" Adapter for 2" Disc  
Qual #: M-18 4" Adapter for 4" Disc

Ideal for cleaning light oxidation & removing gasketing residue. Use on variety of surfaces including engine blocks, heads, valve covers & trans. housing

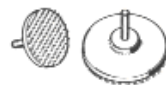

### ROLOC DISC PAD ASSEMBLY

M-14 2" Adapter for 2" Disc  
M-25 4" Adapter for 4" Disc

Both have 1/4" Diameter Shaft

Used to quickly remove cut cork or paper gaskets and form-in-place gasketing materials prior to the assembling of power train components



### CUT-OFF WHEELS

Qual #: M-22 3" X 1/16 3/8Arbor Pkg 25  
Abrasive wheels are designed for cut-off applications involving angle iron, re-barb, pipe & barstock

Qual #: MMM-01990 Pkg 5  
3" X 1/16 Heavy Duty



### GREEN CORPS ROLOC DISCS

Handy quick change tool for disc grinding which fits any standard 1/4" drill or air tool. Quick 1/2 turn on, 1/2 turn off.

Grit determined by color of plastic holding button.  
Grade 50 -green  
Grade 36- brown  
Grade 24-black

Qual #		
MMM-01398	24/Black	2"
MMM-01408	24/Black	3"



## Grinding Wheels

### GENERAL PURPOSE WHEELS

All wheels 6" Diam. With 1" hole. Comes equipped with 1/2", 5/8", 3/4" arbors. Packed 1 to a box



Qual#	Qual#	Desc
3/4" Wide	1" Wide	
20141	20143	Coarse
20140	20144	Medium
20142	20145	Fine

Qual #: 20146	8x3/4
Qual #: 20147	10x7/8

### WIRE WHEELS MEDIUM DUTY

Qual#	Dia.	Face Width	Arbor Hose	Wire Size
20180	6"	13/16	5/8-1/2	.014
20181	7"	7/8	5/8-1/2	.014
20182	8"	1"	3/4"	.014



### WIRE WHEELS HEAVY DUTY

Qual#	Dia.	Face Width	Arbor Hose	Wire Size
20183	6"	1-1/16	5/8-1/2	.014
20184	7"	1-1/16	5/8-1/2	.014
20185	8"	1-1/4	3/4"	.014
20186	10"	1-5/8	3/4"	.020



### TYPE 27 METAL WHEELS

General purpose applications in mild steels or for multi-applications users grinding stainless steels, and alloy steels. For grinding or cut-off in electric or air powered right angle grinders.

Qual #	Size
M-41	4 X 1/4 X 5/8
M-42	4-1/2 X 1/4 X 7/8
M-43	7 X 1/4 X 5/8
M-44	9 X 1/4 X 5/8-11



**CAUTION:** Any cutting tool may break or shatter under improper use. Government regulations require use of safety glasses and other appropriate safety equipment at all times in vicinity of use.

### TWISTED TUFT WIRE WHEEL BRUSHES

Qual#	Dia.	Face Width	Arbor Hose	Wire Size
20187	6"	1/2"	5/8-1/2	.012
20188	8"	1-1/8	3/4"	.016
20189	10"	1-3/8	3/4"	.016



### WEATHERSTRIP

PEEL-BAK is an easy to apply type of weather stripping for auto and household use. May also be used on boats, refrigerators or anyplace a weatherproof, permanent seal is required. Simple to use – just peel back the liner tape and press into place, no cement or tacking required

Qual#	Thick-ness	Width	Qual#	Thick-ness	Width	Qual#	Thick-ness	Width
31850	5/32	3/8	31854	5/16		31858	7/16	3/8
31851	5/32	1/2	31855	5/16	1/2	31859	7/16	1/2
31852	5/32	3/4	31856	5/16	3/4	31860	7/16	3/4
			31857	5/16	1"	31861	7/16	1"



### WEATHER STRIPPING FASTNERS

#### BLACK NYLON

Door Flange  
GM  
Box 50  
Qual #: 30620



#### BLACK REAR COMPARTMENT

Filler Box 50  
Head Dia: 1 1/16"  
Prong Lgth: 1 1/16"  
Prong width: 3/764"  
GM 1963-on  
Qual #: 36914



#### BLACK NYLON

Weather strip Retainer  
GM Box 50  
Qual #: 37744



#### BLACK NYLON

Weather strip Retainer  
GM 1963-on  
Box 50  
Qual #: 38120



#### BLACK NYLON

Weather strip Retainer  
GM, Ford, AMC  
Qual #: 38612



## Shop Supplies

### PLASTIC OIL BOTTLE KIT

Qual #: 1290  
Kit Contains:  
8 Plastic Bottles  
8 Vented Plastic Spouts  
8 Plastic Dust Caps  
1 8 comp. Metal carrying basket Sold as complete unit only. Ideal for bulk motor oil, transmission fluid, anti-freeze, brake fluid.



### SPRAYER UNIT

Qual #: 60245-T Trigger  
Qual #: 60245 Bottle  
Refillable plastic squeeze bottle with trigger sprayer. Good for windshield cleaner.



### HEAVY DUTY LEVER ACTION GREASE GUN

Qual #: 300  
14 oz. Loads three ways (14 oz. Cartridge, bulk suction, or bulk by dispenser.)



### AIR GUN

Qual #: 301  
Head assembly is plated, air cylinder black oxide, barrel assembly dark blue enamel delivers 1,500 to 9,000 psi each time trigger is pressed Requires air supply of 30-150 psi.



Qual #	Description
5238	Set of 4 Wheels
5239	Creepers
5240	Headrest
5241	Creepers H.D.



## Shop Supplies

### GREASE INJECTOR

Qual #: 302

Needle w/ protective plastic cover.



### WHEEL BEARING GREASE

Qual #: 5905

Lithium complex NLGI#2 all purpose grease in 1 lb. can ASTM dropping point 500°F minimum. Provides excellent heat corrosion & water resistant properties.

### SUCTION PUMP

Qual #: 307

Portable pump, heavy duty all steel construction with durable VITON plunger. Complete w/8ft. of vinyl hose to handle up to 90 wt. Fluids & features a double check valve. Delivery is 1 gal/8 cycles, hand operated, self priming.



### GREASE GUN HOSE

Fits all grease gun accessories. For use on all hand operated grease guns only (not for power operated lube equipment) Heavy duty, high quality 1/8" NPT male fittings on each end. Recommended working pressure 3,000 psi. Burst pressure is 12,000 psi. Meets U.S. Gov. Spec. MIL-L 4387C



Qual #: 303 12"

Qual #: 304 18"

### PLATED OIL SPOUT

Qual #: 308

Plews deluxe spout features a full 8-1/2" spout and leak resistant neoprene gasket. Dual orifices in tempered steel cutting blade offer more complete can drainage & rapid pouring. Best used on 1 qt.-1 gal. Size cans.



### EPOXY FINISH OIL SPOUT

Qual #: 309

Rugged epoxy finish. All metal construction with 7-1/2" spout. Dual orifices in tempered steel cutting blade offer more complete can drainage & rapid pouring.



### GREASE FITTING TAPPING TOOL

Qual #: M-110 Taps 1/4"-28. Wrench fits 5/16 & 3/8" hex, easy out for 1/4"-28 broken fittings



Qual #: M-111 Taps 1/8" NPT. Wrench fits 7/16" and 3/8" hex, easy out for 1/8" NPT broken fittings.

### DRAIN PANS

Qual #: 310

5 gal. Lift drain has a red enamel steel construction, wide mouth tapered plastic funnel, and thumb screw height adjustment.



### PAN ADAPTER

Qual #: 311

Black plastic Transmission pan adapter rests on top of 310 funnel and allows for easy removal of automatic transmission pan.



### GREASE GUN TIP

Qual #: M-112

For use with hand guns only. Inlet 1/8" NPT female. Small diameter permits easy contact with recessed fittings.



Qual #: 314

Galvanized Steel.  
13 qt. 17-1/2 dia. ribbed.



### CASTER BASE

Qual #: 312

Caster Base for lift drain, adjustable, red enamel finish.



Qual #: 315

Galvanized Steel  
6-1/2 qt. 12" dia.



Qual #: 316

4 gal. Pouring spout & handle  
Hi-strength Plastic



### BEARING PACKER

Qual #: 305

For all grease guns. Can be used with either hand operated or power lube equipment. For all bearings measuring : min. ID 3/8" max. OD 5". Working height between cones from 1/4" to 2". Easily lubricates bearings. Zinc plated. 1 per card.



Qual #: 317

6 gal. Radiator Drain Pan. H.D. galvanized steel. Includes anti-splash baffle, & handles. 19" dia. X 6' high.



Qual #: 318

16" x 25" sheet metal. Pan



Qual #: 319

31"x12"x12" Plastic test  
tube tank



Qual #: 320

12 qt. Galvanized sheet metal  
Water Pail



### MULTI-PURPOSE GREASE

Qual #: 306

A lithium base grease that performs well under a wide temperature range of 0° to 265°F. Water insoluble. Use in most automotive, agricultural & industrial applications including chassis and other grease lubricated bearings. Economical grease of normal temp/speed conditions and jobs requiring frequent re-greasing because of a contaminating environment. NLGI Grade 2.



### RED LITHIUM GREASE

Qual #: 306-R

High Temperature lithium complex disc & drum wheel bearing grease in 14oz. tube. The high dropping point makes this grease suitable of operating temperatures from -40°F to 350°. Meets both NLGI GC & LB classifications

## Shop Supplies

### GALVANIZED MEASURES

State approved measures. Hot dipped rugged funnel. Measures with spill proof tops. Angled spouts for ease of pouring. Rolled edge, easy grip handles. Calibrated fill line. Available in both rigid & flexible spout models.

Qual#	Type	Size
322	Rigid	1qt.
325	Flexible	1qt.
326	Flexible	2qt.
327	Flexible	4qt.



### PAINTED MEASURES

Thumb control paint measures with swing spouts. Designed for one hand operation. Thumb operated valve controls flow, flip action locks valve open. Both rigid and flexible metal spouts swing into the necessary angle for hard to reach jobs. Recessed bottoms drain fully and guard against puncture. Rolled edge top prevents oil spillage. Bright blue enamel.

Qual #: 375	Flexible	2qt.
Qual #: 376	Flexible w/ Tapered tip	5qt.
Qual #: 377	Flexible	8qt.



### BATTERY & RADIATOR FILLERS

Qual #: 328

Shuts off automatically when battery cell is properly filled. Features the double action fast flow valve tip that prevents after-drip. Stops surface discharge caused by a wet battery. Tough blue polyethylene. Safe to use with battery acid. 2-1/2 qt. Capacity.



### RADIATOR FILLER

Qual #: 329

3 gal. Rugged black plastic



### RADIATOR FILLER PAIL

Qual #: 330

3 gal. galvanized



### PAINTED PISTOL OILER

Epoxy finish with no leak full drawn steel bodies.

Qual #: 336

6oz. w/base 5" rigid spout



Qual #: 337

6oz. w/ base 6" flex spout pistol type

Qual #: 338

1 pint Pistol type 7" rigid horz. spout



Qual #: 339

7/8 pint handle type /8" flex spout

### FUNNELS

#### HEAVY GALVANIZED STEEL

Capacity indicates what the funnels will hold when the outlet is blocked.

Qual #: 347 1 qt. 4-1/2" diameter w/strainer

Qual #: 348 8 qt. 9-1/4" diameter w/strainer



#### PLASTIC UTILITY FUNNELS

Qual #: 349 2 qt. 8" utility

Qual #: 350 6 qt. 8-3/4" w/ filter screen

Qual #: 354 1 pint 6" utility



#### TIN UTILITY FUNNELS

Qual #: 351 2 qt. 6-1/2" funnel



### FUNNEL FILLERS

#### TRANSMISSION FILLER

Qual #: 352

Transmission filler w/screen. Sharp, hardened can cutting blade for complete can opening & fast pouring. 2 qt. 8-1/2" diameter. Includes fine mesh strainer screen.



#### ALL PURPOSE FUNNEL

Qual #: 355

Two piece, all purpose utility funnel. Extra long neck to reach out of the way spots. To use, remove bottom portion & place in radiator neck.



#### METAL BARREL PUMP

Qual #: 358

For light oils in 15-55 gal drums w/2" bung opening



# Truck Equipment

## POLARIZED DIE CAST ALUMINUM GLAD HANDS

- Qual #: V-035038 UNIVERSAL
- Qual #: V-035042 EMERGENCY
- Qual #: V-035045 SERVICE



1/2" FPT Port. Connection plates color coded for easy identification. Interchanges with: BW 278850, Berg 11452, Midland N-1202-BC, VWeatherhead W78850

## HOSE COUPLING SEALS

- Qual #: V-035005 STANDARD
  - Qual #: V-035007 FLAT TYPE
- Pkg 25/ box



## COILED NYLON AIR BRAKE HOSE

Tractor Trailer Connector Kits with standard 1/2" M.P.T. Ends



- Qual #: V-022000 12 ft. wit two extra 3/8" M.P.T. fittings
- Qual #: V-022025 15 ft. working length

## ELECTRICAL ADAPTORS

- Qual #: V-591009 ATA 7-way to 6-way adaptor.
  - Qual #: V-591010 6-way to ATA 7-way adaptor.
- Contact terminals are precision screw machine parts made from solid brass. Wires an Terminals are ATA color coded



## HOSE HOLDER

with snubber chain & air coupling holders

- Qual #: V-581005 40"
- Qual #: V-581036 50"



For holding 3/8" I.D. air hose made of steel & rubber coated. Factory assembled.

- Qual #: V-580003 2 HOLE
- Qual #: V-580007 3 HOLE



## COUPLING HOLDERS

- Qual #: V-035037 DUMMY



## HOSE BRACKET

Two piece bracket. Each mounts independently. Comes with screws & two clevises for springs

- Qual #: V-580017



## HOSE SPRINGS

Double loop each end. Extra length & thickness.

- Qual #: V-038001 3/4 x 13" STANDARD
- Qual #: V-038003 1" x 13" HEAVY DUTY
- Qual #: V-038005 1.125 x 28" HEAVY DUTY



## LICENSE & PERMIT HOLDER

- Qual #: V-090060

Two piece ,durable, clear LEXAN holder. Inside dimensions are 3-1/8-3-3/4" wide by 5-1/2" high. Documents are held in place by the clip and metal plate attached to the cover. Two wing nuts hold the cover Securely in place and compress a gasket that seals out moisture.



## UNIVERSAL AIR TOGGLE VALVE

- Qual #: V-032037
- For PTO or Power Divider



## AIR BRAKE DIAPHRAGMS

Clamp Ring Type

Type	Qual #	Type	Qual #
9	V-031021	24	V-031031
12	V-031023	30	V-031033
16	V-031025	36	V-031035
20	V-031027		



Diaphragm

## SEAT VALVE

- Qual #: V-032110
- Durable, 3-way valve with spring centered off position that will replace most non-automatic leveling seat valves. It can also be used to control single acting air cylinders



## SAFETY VALVE

- Qual #: V-030075
- 1/4" Male Pipe Inlet. Blow off at 150 P.S.I.



## LINE IDENT TAGS

- Qual #: V-035026 SERVICE Made of 22 ga. Aluminum with 7/8" diameter hole. Lettering is bright red enamel.



## AIR BRAKE DRAIN VALVE

- Qual #: V-032082
- With 5' cable. Allows removal of built up moisture and contaminants from air tanks. Pulling the attached cable from any direction opens valve. Valve closes automatically when cable is released. Vinyl covered galvanized aircraft cable is securely attached with copper oval sleeves.



## STOPLIGHT SWITCH

- Qual #: V-036036
- Contacts close at 2-6 P.S.I. for long advance warning. Two terminal style with 1/4" M.P.T. Interchanges with other comparable switches.





## Truck Equipment

### LOW AIR PRESSURE SWITCH

Qual #:V-036039  
1/8" female pipe thread. Contacts close at 60 lbs. or less



### AIR PRESSURE GAUGE

Qual #:V-035065  
for 1/8" FPT port. Pressure range 0-160 psi



### TRUCK CAB GRAB HANDLE

Qual #:V-690021 12"  
Qual #:V-690022 18"  
Qual #:V-690023 24"

Made from heavy gauge Duplex Chrome plated steel tubing 3/4" dia. with 5/16" mounting holes.



### ELBOWS

	Hs ID	Pipe Thd
Qual #:V-175033	1/2	3/8
Qual #:V-006035	1/2	1/2



### THREE WAY TEE

Qual #: V-175051 3 Ends 1/2"



### MALE CLEVISES

Qual #: V-019027

A	B	C	D	E
7/16-10	7/16	2-1/4	1/2	1



### DUMMY COUPLING

Used to seal female coupling when trailer is connected from towing vehicle. Qual #:V-175006



### UNIVERSAL COUPLING HOLDER

Uses the same spring loaded sleeve, tight grip principle of the V-175002 female coupling. Grips all SAE male vacuum couplings & seals the line when not coupled to the trailer. Holder bolts to back of truck cab. Qual #:V-175008



### HOSE & CABLE SUSPENDERS

Qual #:V-580081	5"	1 PER PKG
Qual #:V-580082	12"	1 PER PKG
Qual #:V-580086	16"	1 PER PKG
Qual #:V-580094	24"	1 PER PKG



### SINGLE POLE CONNECTORS

Single pole plug with ground terminal. Power & ground term holds up to 1/0 wire. Qual #:V-591081



### SINGLE POLE SOCKET

With ground terminal. Power & ground holds up to 1/90 wire. Qual #:V-591086



### DIESEL FUEL VALVES

GATE VALVE  
Qual #:V-060050 1/2 F.P.T.  
Qual #:V-060023 3/8 F.P.T.



### FRAME COUPLING

Qual #:V-035081 1/4" 3/4-16 mounting thread .Zinc Plated steel construction . FPT both ends



### COOLANT SHUTOFF VALVE

All brass construction. Hose O.D. 5/8, Pipe Thread 1/2  
Qual #:V-023108



### GAS CAPS

Vented aluminum caps meet requirements for vehicles built after Oct 1985. Vented brass caps designed for use only on vehicles with non-vented fuel systems built prior to Oct 1985. Non-vented brass caps are designed for use only on vehicles equipped with properly vented fuel systems.

Qual #:V-600007 Gas or Diesel, Female, Vented, Non-Locking  
Qual #:V-600011 Gasket for V-600007  
Qual #:V-600017 Gas or Diesel, Male, Vented, Non-Locking  
Qual #:V-601056 Bayonet Diesel, Vented, Locking  
Qual #:V-601065 Bayonet Diesel, Vented, Non-Locking



### SEVEN-WAY COILED CABLE ASSEM

6/12 1/10 Gauge  
Durable black outer jacket with, HD zinc die cast plugs with spring guards included

Qual #:V-590156 12 feet  
Qual #:V-590157 15 feet



### DOOR HOLDER LINK TYPE

All Steel Zinc Plated  
Qual #: 57051 Supplied w/2" Link  
Qual #: 57052 Supplied w/4" Link

### RING & "S" HOOK KIT

Qual #:V-580078  
Ring and "S" Hook Kit for cab mounted hose suspender bar (hose suspender not included)V-580078

Qual #:V-580076 "S" Hook





# Mirrors And Mirror Assemblies

## WEST COAST MIRRORS

### 7"X16" STANDARD V-BACK MIRRORS

96 sq. inch viewing area, Replaceable 1/8" glass, Round cornered, one piece housing, Gasket cushions edge shock 5/16"-18 plated mounting bolts & locknuts included, Avail. in 400 series stainless steel and powder-coated steel finishes.



Qual #:V-708001 Black  
Qual #:V-702044 Glass  
Qual #:V-708003 White

### 7"X16" STANDARD OEM MIRRORS

96 sq. inch viewing area, Replaceable 1/8" glass, Round cornered, one piece housing, Gasket cushions edge shock, 5/16"-18 plated mounting bolts & locknuts included, Avail. in 300 series stainless steel and powder-coated steel finishes.



Qual #:V-708022 Stainless

### 7"X16" HEATED OEM MIRRORS

In addition to standard OEM features, this heated mirror also offers Temperature-controlled heating 5' cord for convenient installation Switch kit for heated heads sold separately 747053



Qual #:V-708046 Stainless

## BLIND SPOT MIRRORS

### 8-1/2" CENTER MOUNT

Convex Mirror with "L" Style Bracket, 13" radius curvature glass.

Qual #:V-708441 Stainless



### 6" CENTER MOUNT CONVEX MIRROR

with "L" Style Bracket. 14" radius curvature glass, Black outer gasket holds glass and offers shock protection

Qual #:V-708478 Stainless  
Qual #:V-708479 Black



### 6" CENTER MOUNT CONVEX MIRROR

with Universal Bracket. 14" radius curvature glass, Black outer gasket holds glass and offers shock protection

Qual #:V-708476 Stainless



### 7-1/2" AND 8-1/2" CONVEX MIRROR

with Off-set Bracket. 12.6" radius curvature glass, Smooth Back

Qual #:V-708509 Stainless  
Qual #:V-708502 Black



## POLYPROPYLENE CONVEX MIRROR

with Clamp and Tubing Arm

Available in 5" glass diameter with 14" radius, 6" dia. with 18" radius, and 8" dia. with 18" radius, Adjustable stud mount ball socket 5/16-18 mounting stud and hex nut.

Qual #:V-723019 5" Silver



## ROUND AND RECTANGULAR STICK-ON MIRRORS

Lightweight aluminum shell Mounts easily using pad with adhesive

Qual #:V-723060 3" Round Stick-on  
Qual #:V-723065 3-3/4" Round Stick-on  
Qual #:V-723075 4" x 5-1/2" Rectangular Stick-on

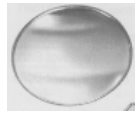
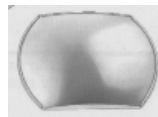

## WIDE ANGLE SYSTEM MIRRORS

6-1/2" x 6" & 6-1/2" x 10" Side Mount Replaceable 1/8" glass on all mirrors. FSC on flat glass and silvered glass with 21" radius of curvature on all convex models, Outer gasket for edge shock protection. 5/16"-18 mounting port Viewing area on flat glass:  
32 sq.in on 6-1/2x6  
55 sq in on 6-1/2x10



## WIDE ANGLE SYSTEM MIRRORS

6-1/2" x 10" Stud Mount Flat Glass Mirror Replaceable 1/8 FSC glass, Outer gasket for edge shock protection, 5/16"-18 mounting stud & hex nut included, 55 sq in of viewing area, DuraBall joint system.

Qual #:V-704268 Ford White



Size	Glass	Color/Material	Mirror#	Glass#
6-1/2x6	Flat	Stainless	V-704093	V-702051
6-1/2x6	Flat	White Steel	V-704078	702051
6-1/2x6	Flat	Silver Steel	DWO V-704083	
6-1/2x6	Flat		DWO V-704038	
6-1/2x6	Convex	White Steel	V-704077	702023
6-1/2x6	Convex	Polished Stainless	V-704040	702023
6-1/2x6	Convex	Stainless	V-704095	702023
6-1/2x6	Convex	Silver Steel	DWO V-704085	
6-1/2x6	Convex	Silver Plastic	V-704185-5	V-702057
6-1/2x10	Flat	White Steel	V-704032	V-702076
6-1/2x10	Flat	Polished Stainless	V-704039	
6-1/2x10	Flat	Stainless	V-704091	
6-1/2x10	Flat	Silver Plastic	V-704181-5	

## Mirrors and Mirror Assemblies

### WALK-IN VAN CHASSIS MIRROR SYSTEM CUSTOM WIDE ANGLE SYSTEM

Pivot preset mechanism allows mirrors to be folded flat and then returned to original viewing without re-adjustment. Sold in pairs and include mirror heads, 3/4 O.D. loops and cabfeet. Most assemblies include side mount mirror heads 6-1/2 x 10" upper flat glass and 6-1/2 x 6" lower convex glass.

Description	Dimension	Qual#
White w/out preset	8.18"x33"	V-727067

### STRAIGHT VAN AND CUTAWAY VAN CHASSIS MIRROR SYSTEMS



### UNIVERSAL LOW MOUNT MIRROR KIT

Qual #: 712479	Stainless Steel Kit
Qual #: V-747116	4" Extension Arm

### UNIVERSAL TRUCK AND VAN MIRROR SYSTEMS

#### BRACKET KIT

For Foldaway Head and Loop Installations.

Suitable for older cutaway van and cab chassis. Sold in pairs and includes stainless steel brackets with preset and mounting hardware

Qual #: V-700075
Qual #: V-700076 White DWO

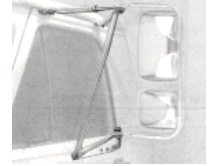

### UNIVERSAL HEAD AND LOOP SYSTEMS

Mirror heads are individually adjustable for proper viewing. Side mount mirror heads form a wide angle system assembly with 6-1/2x10" upper flat glass and 6-1/2"x6" lower convex.

7" x 16" West Coast



Qual #: V-701001	White
Qual #: V-701006	Stainless



Qual #: V-70105	White
Qual #: V-701054	Stainless

### FLAT GLASS HEAD

1/8" FSC glass with 63-5/8 sq. in viewing area. Rolled edge design holds glass & gasket securely. DWO indicates "while supplies last"

Qual #: V-709003  
Polished stainless DWO

Qual #: V-709004  
White DWO  
Qual #: V-709002  
Stainless



### CONVENTIONAL TRACTOR BRACKET KIT

Adjustable 3/4" O.D. tubing arms for universal fit on a variety of straight truck and truck tractors. Bracket extends outward 20" from vehicle. Sold in pairs.

Qual #: V-700064



## Brackets, Clamps, Hardware And Accessories

### CLAMP & TUBING ARM KIT

for 5 & 6" Plastic Mirror Heads.  
For 5/8 & 3/4 O.D. tubing.  
Length 5-7/16"

Qual #: V-723049	Aluminum
------------------	----------

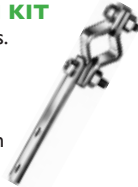

### CLAMP & TUBING ARM KITS

for 6, 8, & 8-1/2" Mirror Heads  
For 3/4 O.D. tubing.  
Length 6"

Qual #: V-723057	Stainless
------------------	-----------



Ideal for adding an auxiliary spot mirror to existing loop or brace

### 6" PIVOT BOLT MOUNTING BRACKET

Ideal for adding an auxiliary spot below West Coast Mirror Head  
Stainless steel construction  
Length 4-7/8"

Qual #: V-723055
------------------



### STANDARD MOUNTING CABFEET KITS

Used on non-preset style loops  
Cabfeet mounting holes are 2" on center.



Qual #: V-757015	Stainless
------------------	-----------

### TWIST CLAMP KIT FOR 3/4" O.D. TUBING

Used to mount West Coast mirror heads to 3/4" O.D. tubing

Qual #: V-704065
------------------



Used to mount West Coast mirror heads to 3/4" O.D. tubing

Qual #: V-704066
------------------



### FOR 3/4" O.D. & 5/8" O.D. TUBING

Used to mount side and center mount mirror heads to 3/4" O.D. tubing.

Qual #: V-704068
------------------



Used to mount side and center mount mirror heads to 5/8" O.D. tubing.

Qual #: V-704069
------------------



Qual #: V-704067 DWO  
Same as V-704068 except with extended Tab length

# West Coast Mirrors

**THE FOLLOWING MIRRORS ARE AVAILABLE "WHILE SUPPLIES LAST."  
DISCONTINUED BY MANUFACTURER (DWO)**

## 6"X16" FLAT BACK MIRRORS

87 sq. inch viewing area, 1/8" glass, Square corned, flat back housing, 5/16"-18 plated mounting bolts & locknuts included.

Qual #:V-705050 Aluminum



## 6"X16" ECONOMY ANGLE BACK MIRRORS

87 sq. inch viewing area 1/8" glass, Angle back housing, 5/16"-24 mounting bolts & split washers included, Black end caps.

Qual #:V-705038 Aluminum



## UNITIZED WIDE ANGLE MIRROR SYSTEM

Includes a lower 6x16" convex mirror with a upper 6x10" flat mirror. Each head independently adjustable. 5/16-18 bolt and locknut included.

Qual #:V-705093 White



## FRONT CROSS VIEW MIRROR

Sturdy tripod mount adjusts to fit most school bus fenders. Large 8" diameter, black plastic convex head with ball stud mount.

Qual #:V-712009



- Qual #: V-712236 Mirror Set
- Qual #:V-714067 D254 mirror
- Qual #:V-721076 Mirror Repla 756050 7 759009
- Qual #:V-726026 D61R mirror
- Qual #: V-747053 Switch for 708007 & 008 heated mirror
- Qual #: V-756094 D64G-C mirror
- Qual #:V-757001 D64J mirror
- Qual #: V-757002 D64J-C mirror

## UNIVERSAL LOW MOUNT MIRRORS

Upper FSC flat glass mirror head 6.5 x 6" lower convex mirror head with 21" radius. Loop with preset feature allows mirrors to fold away and be returned to original positions. Adjustable upper tubing arm and mounting brackets fit mirror vertically on a variety of door contours.

Qual #:V-721082 Stainless



## "L" MOUNTING BRACKET

Qual #:V-723053

For 1/4 & 5/16 pivot bolts Ideal for adding spot mirror below West Coast Mirror head.



## 12 VOLT HORN

Qual #: 11874

High output for safety. Meets SAE and OEM specifications.

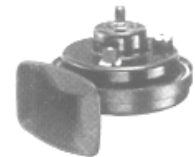

## TRUCK ACCESSORY

### TRUCK & TRAILER SPLASH GUARDS

Fully molded rubber \* Cord Reinforced \* Seal Insert \* Endorsed by leading Highway Safety Authorities

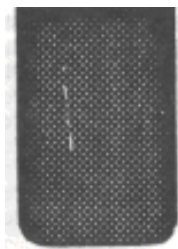

Qual#	Size
11850	20 x 20
11851	24 x 30
11852	24 x 36

Also available upon request QUALITY personalized flap is a one-piece single unit- molded to your name or trademark specifications. Choice of Dupont Hypalon colors on name or trademark. Ask for price quote.

Qual #s: 11853, 11854, 11855, 11856

### DOCUMENT STORAGE CASE

Qual #: 11863

9" Aluminum Tube w/cable. Holds a variety of documents: registration, permit, manifest.

**Dimensions:**  
Bracket 5-3/4" H x 4" D

CapKeeper cable eliminates lost caps Patented cap design creates watertight seal and prevents accidental opening.

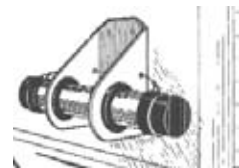

## Truck Equipment

### COMBINATION BALL HITCHES W/HARD CHROME BALL

Qual #: 57000  
8 Ton Capacity  
16,000 Lb. Gross Trailer Weight  
3,000 Lb. Maximum Vertical Load

#### FEATURES

- Chrome-moly Ball with Hard Chrome Surface
- Interchangeable Hitch Balls
- Large 1-1/8" Ball Shank with Indexing Flats To Compensate For Wear
- 100% Drop Forged Construction
- 1/4" Dia. Locking Pin
- Standard Mounting Pattern



### REPLACEMENT BALLS W/ LOCKNUTS

Qual #: 57001 1-7/8  
Qual #: 57002 2"  
Qual #: 57003 2-5/16

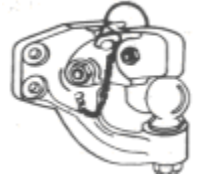

Qual #: 57020  
Max. Gross Trailer Wt. 42,000 Lbs  
Max. Vertical Load 6,000 Lbs  
Shipping Wt. 14 Lbs  
Alloy Steel Forging  
2-1/2" I.D. Ring

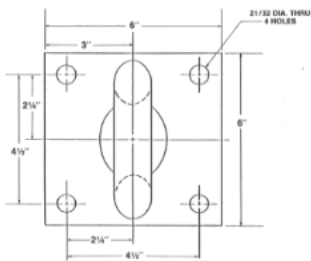
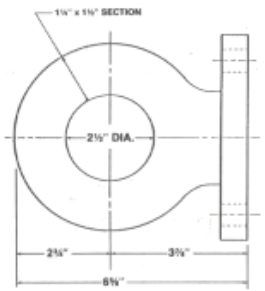

Qual #: 57021  
Max. Gross Trailer Wt. 15,000 Lbs  
Max. Vertical Load 3,000 Lbs  
Shipping Wt. 9 Lbs  
Alloy Steel Forging  
2-1/2" I.D. Ring

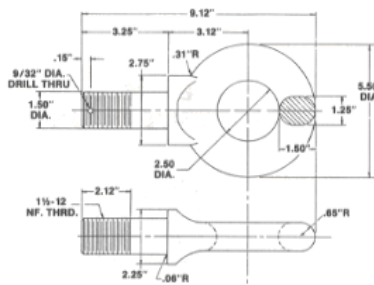

Qual #: 57022  
Max. Gross Trailer Wt. 60,000 Lbs  
Max. Vertical Load 15,000 Lbs  
Shipping Wt. 20 Lbs  
Alloy Steel Forging  
3" I.D. Ring

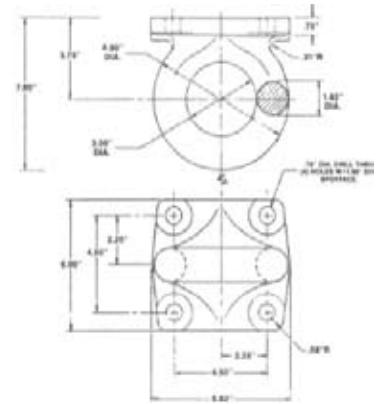

### LUNETTE

Qual #: 57030  
Drop Forged C-1020 Steel  
Pulling Capacity 10 Tons



### HITCH PIN 5/8 W/ COTTER

Qual #: 57017



# Truck Equipment

## PINTLE HOOK ASSEMBLY W/ LOCKING CHAIN

Qual #: 57005

Alloy Steel Drop Forging  
Open Type, Rigid Mount  
30,000 Lbs Capacity  
6,000 Lbs Vertical Load  
Weight 11 Lbs



## SWIVEL TYPE PINTLE HOOK W/ SPRING CUSHION

Qual #: 57010

- 20,000 Lbs Max. Gross Trailer Weight
- 4,000 Lbs Max Vertical Load

Pintle hooks are individually boxed and include mounting information sheet, spec. sheet, and vehicle capacity decal.

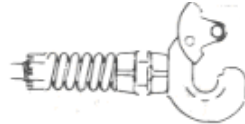

## PINTLE MOUNT ADAPTORS

These mounts are designed to adapt receiver tubes to multi-height pintle hook applications.

### FEATURES

- Continuous Welds
- Epoxy Coating
- High & Low Positioning
- Welded Support Bracket



Qual #: 57015



Qual #: 57016

## TOWING HOOKS

### NORMAL DUTY

Right and left hand, pattern, Drop forged, Standard 4-3/16" hole center, Max. Safe working load: 13,500 lbs

Qual #: 57025 Right Side

Qual #: 57026 Left Side



### EXTRA HEAVY DUTY

Right and left hand pattern, Drop forged, Standard 4-3/16" hole center, Max. Safe working load: 44,600 lbs

Qual #: 57027 Right Side

Qual #: 57028 Left Side



## LIGHT DUTY TOW HOOKS

Universal pattern, drop forged steel, chrome plated or black enameled. Max. Safe working load 10,000 lbs

Qual #: 57031 Chrome Plated



Qual #: 57032 Black Enameled



## DOOR HOLDER HOOK & KEEPER

Steel stamping zinc plated, Both include Hook and Keeper

Qual #: 57045 4" Hook

Qual #: 57046 6" Hook



## DOOR HOLDER & PLUNGERS

Zinc Finish,

Qual #: 57047

2-5/8" overall 2-1/4" plunger

Qual #: 57048

3-1/8" overall 2-3/4" plunger



## SOCKET WITH RUBBER INSERT

Qual #: 57049

Rubber Insert only (large Hole) 25-30lb.

Pull to release. Qual #: 57050

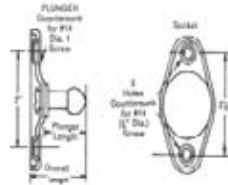

## BINDING HOOK

Qual #: 57029

5" Long  
1 1/32" Holes  
1/2" Round cross section



## EYE BOLTS

Qual#	Safe Load*	Ult. Load*	Thread Stocked	Shank		Eye	
				A	B	C	D
57035	.2	1.5	1/4-20	1/4	1	3/4	1-3/16
57036	.7	3.0	3/8-16	3/8	1-1/4	1	1-21/32
57037	1.3	5.0	1/2-13	1/2	1-1/2	1-5/16	2-1/16
57038	2.0	8.0	5/8-11	5/8	1-3/4	1-3/8	2-1/2
57039	3.0	12.0	3/4-10	3/4	2	1-1/2	2-13/16
57040	3.5	16.0	7/8-9	7/8	2-1/4	1-11/16	3-1/4
57041	4.0	20.0	1-8	1	2-1/2	1-13/16	3-9/16
57042	5.6	33.5	1-1/4-7	1-1/4	3	2-3/16	4-7/16
57043	9.0	42.0	1-1/2-6	1-1/2	3-1/2	2-9/16	5-1/2

\* In Tons of 2000lb,

Dimensions in inches

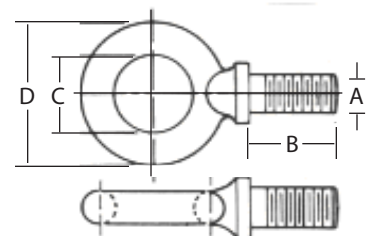



## Safety & Protection Products

### RIGID FRAME CUPS GOGGLES

#### PLASTIC CUP SIDE SHIELDS SPATULA TEMPLS

Qual #: 24351



#### CHIPPERS GOGGLES

Qual #: 24343

Thermoplastic. Will not fit over prescription glasses. Insulated nose chain permits automatic adjustment to facial contours. 50mm clear lenses.



#### SOFT VINYL

Qual #: 24341

These cover goggles offer comfort and protection against flying particles, dust, and splash. Soft frame with perforations for maximum ventilation. Optical quality, distortion-free. Fits all sizes and shapes, even over large size prescription glasses.



#### WELDERS GOGGLES

Qual #: 24342

with 50mm IRex plastic welding lenses.



### PROTECTIVE HELMETS

Classic Style Hard Hat with 6-pt. Self-sizing suspension. Equipped with accessory slots for attaching items such as earmuffs, face shields, or communication devices.

Qual #: 24362 Yellow

Qual #: 24363 White



### PARTICULATE RESPIRATOR

Qual #: MMM-07048 Bx/20

General Industrial use in bagging, drilling, grinding, machining, sanding, sawing. Mask does not supply oxygen.

#### COMFORT MASK

Qual #: MMM-06985

Good for use in relief from irritants such as dusts, pollen, and animal dander. Bx /50



### EMERGENCY WARNING TRIANGLE

This light weight (12lbs) system comes in a 15" x 4-1/4" x 4" Red Opaque Case. Easy to use. Legs simply lift up and snap together. MEETS FMVSS 125 as required by Motor Carrier Safety Regulations MC-23.

Qual #: 130

Qual #: 130-BO (BOX ONLY)



### FIRE EXTINGUISHER

Qual #: 756

Kidde B:C dry chemical extinguisher with bracket. Disposable unit wt. 2.75 lb.

Qual #: 757

Kidde B:C dry chemical extinguisher with bracket. Rechargeable unit wt. 2.75 lb



### SAFETY KITS

#### BURN KIT

Qual #: 758

Includes contents used to treat minor burn injuries. Water-Jel dressings to relieve pain while preventing contamination. Easy carry or store plastic box.

#### FIRST AID KIT

Qual #: 759

Ideal first aid for minor injuries. Housed in plastic box

#### UNIVERSAL PRECAUTIONS KIT

Qual #: 01-1013

This kit allows for effective clean-up of bodily fluids such as vomit, blood in a one time use set-up.



### DISPOSABLE GLOVES

#### POWDER-FREE LATEX GLOVES

Qual #: 01-1012 100/box

Qual #: 01-1012-XL 100/box

Powder-free, textured, latex gloves provide an excellent biological barrier. Good for general uses. Textured finish allows for good grip.

#### POWDERED LATEX GLOVES

Qual #: 01-1016 100/box

Powdered Latex gloves offer the added comfort of an absorbable powder for hand moisture.



#### POWDER-FREE NITRILE GLOVES

Qual #: 01-1015 100/box

Qual #: 01-1015-XL 100/box

Powder-free NITRILE gloves are an alternative for those allergic to latex. Single-use convenience in a dispenser box.



### UNIVERSAL SORBENT PADS

Qual #: SPC-100 cs/100

Gray Dimpled Sorbent Sheets, 15x19 absorbs/weight, 29GL/20LBS, Good for oil and water based fluids.



### TWO PIECE PVC RAIN SUIT

Moderately Priced with Detachable Hood. Jackets have waist level covered pockets, Snaps on wrists and front. Draw cord pulls jacket tight over hips. Corduroy lined collar to absorb perspiration. Trousers Full cut fits comfortably. Adjustable elasticized suspenders. Snaps at ankles and around waist.

Medium #89  
Large #85  
Extra Large #86

### HEAVY DUTY ALL PURPOSE RAIN SUITS

Jackets and trousers offer all the features of the moderately priced suits along with Bright Yellow for safety. Soft and comfortable even in cold weather. Non-adhesive- non flammable- tear and wear resistant- fully welded seams- double needle construction- easily washed in lukewarm soapy water.

Medium #90  
Large #87  
X-Large #88  
XX-Large #92





## Safety & Protection Products

### THE WORK HORSE

Qual #: 01-1000

Features: Finest quality side split cowhide - full leather wing thumb and index finger - flannel lined palm-leather pull and finger tips - knuckle strap - rubberized, water-proof safety cuff - Gunn pattern-man size Color: grey leather; red and blue herringbone canvas Available in several grades



### THE BRONZE WELDER'S GLOVE

Qual #: 01-1004

Features: Same high quality as our Gold Welder's Glove, bronze split cowhide leather construction, single piece thick back for extra protection, seamless index finger, welted wing thumb, five inch safety gauntlet, fully lined to cuff, remains soft and flexible for long periods of use, Gunn pattern.



### DRIVER'S GLOVE

Qual #: 01-1008

Features: First quality extra soft and smooth grain leather - unlined with elastic shirred wrist for comfort - stays soft and pliable - Gunn pattern - man size, Color: tan



### BROWN JERSEY ALL PURPOSE GLOVES

Qual #: 01-1010

Features: 8 ounce 100% cotton with fleeced interior for comfort - knit wrist - clute cut, Color: dark brown



### THE WELDER'S GLOVE

Qual #: 01-1003

Features: All leather construction - seamless index finger - welted wing thumb - 5" long gauntlet safety cuff - fully lined - remains soft and flexible for long periods of use - Gunn pattern - made specifically for use in welding - man size, Color: grey leather



### THE MULTI-PURPOSE

Qual #: 01-1007

Features: Select side split leather - elasticized wrist or ball and tape on back - maximum dexterity and fit - ideal for driving, - light assembly work, gardening, etc. - Gunn pattern - man size, Color: grey leath



### COTTON CANVAS ALL PURPOSE GLOVES

Qual #: 01-1009

Features: 8 ounce 100% cotton in sturdy twill weave - fleeced interior for comfort - knit expansion wrist - clute cut, Color: natural



### COTTON INSPECTION GLOVES

Qual #: 01-1011

Features: Light weight, 100% 1 ounce hemmed cotton, two-piece construction, soft texture to minimize abrasion, lint free, comfortable to wear, disposable, Color: white



## Paper Goods

### TOILET PAPER

Qual #: 75192

1,000 sheets 96 rolls/case

Qual #: 75189

9" Jumbo Rolls 12 rolls/cs



### C-FOLD TOWELS

Qual #: 75193

2,400 sheets/ cs



### RAGS IN A BOX

Qual #: 75190 Blue 200/bx

Qual #: 75260 White 200/bx



### HOT CUPS

Qual #: 75203

10 oz., 1000/cs.



### PAPER TOWEL ROLLS - BROWN

Qual #: 75191

12 rolls / case - Brown

### JUMBO TISSUE DISPENSER

Qual #: 75199

10-3/4" x 4-4/5" x 10-3/4"

Smoke Gray



### WHITE KREW 400 SHOP TOWELS

Qual #: 75261

12 pkgs of 56/cs



### GARBAGE LINERS

Qual #: 75194 55 Gallon 100/case

Qual #: 75195 13 Gallon 500/case

Qual #: 75196 20-30 Gallon 250/case



### ROLL TOWEL DISPENSER

Qual #: 75187

10-3/4" x 9-3/5" x 13-3/8"



### PAPER TOWEL ROLLS - WHITE

Qual #: 75191A

30 Rolls / case - White

## Drop Lights

### WORK LIGHT W/ 25' CORD

Qual #: 15600

Yellow handle with galvanized lamp shield. Thermoplastic cord insulation with molded plug. Push On/Off switch. NEMA 5-15R receptacle Use 75 watt "rough service" bulb. (not included)

Qual #: 15602

OSHA approved - 3 wire - has no outlet or on/off switch

### WORK LIGHT W/ 50' CORD

Qual #: 15601

Yellow handle with galvanized lamp shield. Thermoplastic cord insulation with molded plug. Push On/Off switch. NEMA 5-15R receptacle Use 75 watt "rough service" bulb. (not included)

Qual #: 15607 OSHA approved - 3 wire - has no outlet or on/off switch

Qual #: 15603

Replacement Handle /Cage Assembly  
Includes instruction sheet and crimp on terminals (3)

Qual #: 15603-A Cage only



### WORK LIGHT ON 50' RETRACTABLE REEL

Qual #: 15604

Steel reel enclosure. Black handle with galvanized steel lamp shield. Push On/Off switch Use 75 watt "rough service" bulb. (not included)



### TRIPLE-TAP EXTENSION CORD ON 30' RETRACTABLE REEL

Qual #: 15606

Thermoplastic cord insulation with Triple NEMA 5-15R receptacle. Steel reel enclosure with NEMA 5-15P molded plug



### FLUORESCENT WORK LIGHT ON 35' RETRACTABLE REEL

Qual #: 15608

Yellow handle with grounded NEMA 5-15R receptacle & rocker switch. Long life (10,000 hour) 13 watt, 4100K, compact fluorescent lamp installed. Adjustable double hook. Ballast in handle. A magnetic base light holder included attaches to handle. High impact HICR lamp protector with light reflector. Clear end cap for spot lighting. Thermoplastic cord insulation with NEMA 5-15P plug and adjustable cord stop. Steel reel. Replacement Tube Assembly for Straight tube Fluorescent available upon request

### FLUORESCENT WORK LIGHT WITH 50' CORD

Qual #: 15609

### FLUORESCENT WORK LIGHT WITH 25' CORD

Qual #: 15609-A

Yellow handle with grounded NEMA 5-15R receptacle & rocker switch. Long life (10,000 hour) 13 watt, 4100K, compact fluorescent lamp installed. Adjustable double hook. Ballast in handle. High impact HICR lamp protector with light reflector. Clear end cap for spot lighting. Thermoplastic cord insulation with NEMA 5-15P plug

### EXTENSION CORDS

3 wire, grounded, HD, OSHA approved

Indoor / Outdoor power center /w 3 grounded outlets

	14 GA	2'	15585
15589	14 GA	100'	15588
15590	14 GA	25'	15586
15591	14 GA	50'	15587
15592	12 GA	100'	
15593	12 GA	50'	



### REPLACEMENT TUBE ASSEMBLY

Qual #: 15615

For STANDARD Series Fluorescent



### ANGLED HEAD REPLACEMENT

Qual #: 15610

### ANGLED HEAD LENS REPLACEMENT

Qual #: 15610-L

Both replacement pieces for Fluorescent Light



### SAFETY ORANGE 3 WAY POWER-CENTER 10' EXTENSION CORD

Qual #: 15594

### 3 WIRE FEMALE

Qual #: 15613



### 3 WIRE MALE

Qual #: 15612



### FLUORESCENT WORK LIGHT ON 50' RETRACTABLE REEL

Qual #: 15608-HD



### 50 FT FLUORESCENT LIGHT REEL

Qual #: 15605

with instant starter switch in handle. Grounded ballast at plug end. Mounts on wall or ceiling. 15 watt fluorescent

# Tapes

## FILAMENT

### REINFORCED GLASS FIBRE STRAPPING TAPE

Qual #: M-223  
Unbreakable-Bi Directional For Taping Iron Parts & Packages, 4 /pkg, 3/4 X 60 yds



## BOX

### CLEAR POLYPROPYLENE BOX TAPE

Qual #: M-231 6/pkg 2" tape  
Qual #: M-231CS 36 rolls  
Qual #: M-232 4/pkg 3" tape  
Qual #: M-232CS 24 rolls



## MASKING

### AUTOMOTIVE REFINISH MASKING TAPE



#### 3/4" X 60 YDS

Qual #	Roll
MMM-6334-1	1 roll
MMM-6334-12	12 rolls
MMM-06334	48 rolls

## ELECTRICAL

### COLD AND WEATHER RESISTANT ELECTRICAL TAPE

Qual #: M-215-J 10/pkg

Qual #: M-216 6/pkg



3/4" x 60', 3M 7-mil. Performs in sub-zero temp. resistant to oil, water, wear, chemicals and solvents.

### MOISTURE SEALANT FOR ELECTRICAL CONNECTORS

Qual #: M-217  
2-1/2" x 10', Self-fusing, rubber-based insulating mastic compounds laminated to all-weather PVC backing  
Moisture sealing for connections up to 600 volts



## DUCT

### GAFFERS TAPE

3" x 60 yds cloth tape in assorted

Qual#: M-226 BLUE

Qual#: M-229 GREY

Qual#: M-227 BLACK

Qual#: M-233 BROWN

Qual#: M-228 GREEN

All numbers above come in single rolls or case quantity of 16 with CS at the end of number  
EX: M-226CS

#### 2" X 60 YDS

M-230-2 Aluminum

M-230-2CS 24/cs

M-230BLK Black, 24/cs

M-230BLK-I

### AUTOMOTIVE GREEN MASKING TAPE 2"

Qual #	Roll
MMM-26340-1	1 roll
MMM-26340-3	3 rolls
MMM-26340	12 rolls

## LABELING

### POST-IT REMOVABLE LABELING TAPE

Qual#: MMM-06951 24/cs  
2" x 36 yds, A white, general purpose labeling tape that is easily removable.



## HAND DISPENSER

Qual#: MMM-06908

A quick and easy way to seal cartons. Used with 2" rolls of box sealing tape. Equipped with metal cutting edge for durability.



## FOAM MOUNTING

Double sided foam tape with easy-release liner, Good for attaching badges, lightweight moldings and trim. Not recommended for medium to heavy weight trim.

Qual#: MMM-06377 1/2"

Qual#: MMM-06378 7/8"

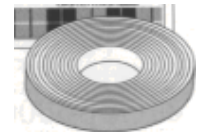

## TEFLON TAPE

Qual#: M-214

1/2" X 520"

Seals all Threaded Connections. Water and corrosion proof Fast and easy to apply. 6/ pkg



## CONSPICUITY TAPE

Qual#: 799

2" x 150'

For improved safety with 2" alternating color reflective tape. All material edge sealed. Meets DOT-C2 certification.

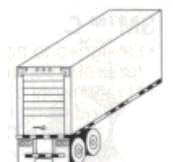

## Soaps & Cleaners

### Hand Cleaners

#### GOJO PRODUCTS

##### HAND CLEANER W/ ITALIAN PUMICE

Qual #: GJ-1135

Effective in removing extra ground-in grease and sticky soils such as adhesives, paint, resin glues. Comes 6 tubs/ case



Qual #: GJ-915

Same advanced cleaning formula as 1135 with Pumice and a fresh Lemon scent. Both contain Vit E, lanolin and aloe. Comes 6 tubs/ case

##### GOJO FAST WIPES

Qual #: GJ-6298



Convenient Pre-moistened towels with an "ORANGE" hand cleaning formula that quickly removes grease, grime, and dirt. Case of 4 /130 count tubs

##### HAND SOAP 25 LBS

Qual #: 11828

#### DL PRODUCTS

##### DL FAST ORANGE FINE PUMICE FORMULA

Fresh Orange scent, Comes with free pump dispenser. Case of 4 – 1 gallon containers. (-1) # EA

Qual #: DL-25-218

Qual #: DL-90-128 Wall Bracket.



##### FAST ORANGE WIPES

Fast Orange Formula in a convenient wipe. Fast and effective Case of 6 tubs or (-1) EA

Qual #: DL-25-072

Qual #: DL-25-072-1



##### FAST ORANGE CREAM W/ PUMICE

Qual #: DL35-406

Qual #: DL-35-406-1



4-1/2 lb. can, Cs/6 (-1) each

##### TROUNCE IN GALLON

Qual #: DL-21-218 (-1) EA

Comes with free pump dispenser, Case of 4, Aloe & lanolin lotion with scrubbing power of pumice grit for those dirty jobs. Great for mechanics, printer, plumbers. The 16 oz. Fits into any tool box.



##### DL GOLD LABEL

Qual #: DL-40-406

A premium cleaner for sensitive hands. A waterless concentrate that's hard on dirt yet easy on skin. Contains an antiseptic that helps prevent dermatitis when used regularly. Case of 6 /4.5lb. can, (-1) EA



##### DISPENSERS

Qual #: DL-95-135

Qual #: DL-95-140

##### 30 OZ. LIQUID SOAP DISPENSER

Qual #: 75188

See-through tank allows easy view of soap level. Hidden, removable back-plate. Large push bar meets ADA requirements.



### Other Cleaners

##### STRIKE FORCE

Qual #: 11900

Qual #: 11900-5 gallon  
Lemon scented Degreaser  
Cs / 12 or gallon



##### STP TUFF STUFF

Qual #: 11806

Perfect for cleaning any washable or painted surface. Deep cleaning foaming action lifts dirt and helps restore true color and appearance. For autos and boats, Tuff Stuff is especially effective for cleaning vinyl and fabric upholstery, floor mats, carpet and chrome. Removes soil and stains from vinyl or fabric upholstery and carpets.



##### KOOL-IT CITRUS SOLVENT CLEANER & DEGREASER

Qual #: 888-1

Foaming Action Aerosol 12 oz. Cleans. Degreases & Deodorizes. No Petroleum Distillates

##### GLASS & HARD SURFACE CLEANER

Qual #: 11805, 11805-1

32 oz pump dispenser KORKAY  
cleans glass, mirrors, tile, stainless,  
porcelain & appliances.

##### CASTROL SUPER CLEAN ALL WHEEL CLEANER

Qual #: 11808-WC

Outperforms other leading wheel cleaners at removing grease and brake dust. Comes in a spray and rinse formula that quickly penetrates wheel surfaces. Safe for all wheel surfaces including any type of wheel rim, cover or hubcap surface. Will not harm glass or painted surfaces - just rinse over sprayed area with water.



Biodegradable, non-flammable, non-abrasive,  
and phosphate-free.

##### CASTROL SUPER CLEAN

Qual #: 11808, 11808-1 & 11808-5

A breakthrough formula for tough cleaning tasks. Biodegradable and Phosphate- Free. Does the job of a variety of multi-purpose cleaners and degreasers. Use full strength on tough jobs or diluted for lighter clean-ups. Sold in spray bottle or 5 gallon containers.



# Cleaners & Chemicals

## Gunk Products

### 16 OZ. ENGINE BRITE

Qual #: 11844

Used to remove grease and grime from autos, power mowers, marine and tractor engines, metals, concrete, tires and industrial equipment where a water rinse is permitted. Cs/12 or (-1) ea



### 19 OZ. FOAMING GLASS CLEANER

Qual #: 11821

A multi-purpose spray without ammonia, cleans windshields and all glass windows, mirrors, appliances, chrome, stainless steel, aluminum, porcelain and ceramic tile. Cs/12 or (-1) ea



### WHITE LITHIUM GREASE

Qual #: 11814

Reduces friction between metal to metal or metal to plastic applications. Aerosol sprays on as a liquid, and then sets up as lubricating grease that will not melt, run, wash off or freeze. Protects against rust and corrosion. Cs/12 or (-1) ea



### WHITE LITHIUM GREASE

Qual #: 5903

1 lb. Tub



### 11 OZ. LIQUID WRENCH SPRAY

Qual #: 1051A

Non-Flammable

Fast penetrating solvents frees rusted and frozen bolts and parts. Rust inhibitor protects metal parts from corrosion. PTFE increases lubricity. Cs/12 or (-1) ea



### 11 OZ. SILICONE SPRAY

Qual #: 11810

A general purpose silicone lubricant in aerosol form. Stops squeaks, rust and corrosion. Excellent mold release. Brightens rubber, vinyl and leather. Protects aluminum and chrome from pitting. No chlorinated solvents. Cs/12 or (-1) ea



### 32 OZ. AIR BRAKE ANTI FREEZE

Qual #: 11819

Qual #: 11817 gal

Contains effective corrosion inhibitors and conditioners to protect metals in air brake systems. Also contains a rubber lubricant to keep seals and diaphragm soft and pliable, as alcohol tends to dry out rubber and leather. Only prime methanol is used to guarantee quality. Cs/12 or (-1) ea



### 12.5 OZ. CARBURETOR CLEANER

Qual #: 11816

Cleans Carburetor, choke linkage and manifold heat controls. Applied by spray to areas to be cleaned. Will not harm catalytic converters or oxygen sensors. Cleans carburetors without removal from engine. Cs/12 or (-1) ea

### 11 OZ. STARTING FLUID

Qual #: 11818

Produce quick, smooth starting of gasoline and diesel engines under extreme cold conditions down to -48° C. Contains at least 45% of Diethyl Ether. Saves battery and ignition during cold weather. Contains upper cylinder lubricant and corrosion inhibitors. Cs/12 or (-1) ea

### FUEL INJECTION CLEANER

Qual #: 11846

Cleans fuel injector nozzles, restoring power to injected engines. Restores fuel economy and power lost through deposit buildup. Cleans up exhaust emissions, which may have resulted from inefficient combustion due to clogged injectors. May be used on gasoline or diesel powered vehicles. Cs/12 or (-1) ea

### RUBBER UNDERCOATING

Qual #: 80018

An aerosol undercoating designed to protect car body from rust and corrosion. Protects against moisture, dirt, corrosive road salt and improves auto body soundproofing. Cs/12 or (-1) ea



### CAR WASH POWDER

Qual #: 11843

Formulated to thoroughly clean without removing wax, 25 lb. Bucket

### BRAKE CLEAN 20 OZ

Qual #: 11811

Brake cleaner quickly removes and flushes away surface contaminants such as brake fluid, oil, from all types of brake and C.V. joint assemblies. It leaves no residue and helps stop disc brakes squeal and "chatter". Cs/12 or (-1) ea



### NON-CHLORINATED BRAKE CLEANER 15OZ.

Qual #: 11811NC

Low VOC formula, Contains no chlorinated solvents, Quickly dissolves and flushes away brake fluid, oil, and other contaminants from all types of brake and CV joint assemblies. Cs/12 or (-1) ea

### COOLING SYSTEM STOP LEAK

Qual #: 11829

Aluminized formula prevents and stops leaks and seepage in radiators, heater cores, blocks, cylinder heads, freeze plugs and gaskets. Specially formulated to effectively work with modern or older cooling systems. Cs/12 or (-1) ea



### BRAKE FLUID

Qual #: 11838

Developed for today's disc, and drum braking systems. Meets DOT 3 Federal Standard number 116. Exceeds Federal Spec. VV-6680 and SAE Spec. J1703.

5 Gallon Container

### 12OZ. AUTO TRUCK DE-ICER

Qual #: 11820

Defrosts auto and truck windshields, wipers and windows instantly. Helps free frozen locks. Ideal for vehicles parked without shelter. Spray in advance to prevent frost formation. Cs/12 or 24 and (-1) ea



### 12OZ. LEAD SUBSTITUTE

Qual #: 11848

Replaces lead protection. Contains valve seat anti-wear additive. Cs/12 or (-1) ea



### FUEL STABILIZER

Qual #: 11842

For storage and everyday use in all two and four cycle engines. Keeps stored fuel fresh. Prevents formation of gum, varnish, and rust. 8oz. Cs/6 or (-1) ea





## FPPF Products

### MELTDOWN

Emergency Road Treatment specifically formulated to dissolve gelled fuel back into solution and return the flow in approximately 20 minutes. Dissolves gelled fuel. Will Not harm fuel pump injectors. Will Not harm precombustion components. Gets fuel flowing in 15 - 20 minutes. Compatible with all types of fuel. Meltdown in an emergency road treatment only. Use Polar Power or Total Power to lower cold filter plug point. (-1) each

Qual #.	Desc	Treats(gal.)	Cs
Fp-00124	32oz.	50	12

### POLAR POWER

This unique formulation combines all the benefits of Fuel Power with the most advanced cold flow improver on the market. Polar Power provides superior protection in the cold weather months. Contains Fuel Power. Contains wax dispersant. Lowers pour point.. Contains seed crystal modifier. Lowers cold filter plug point.. Contains No Alcohols! (-1)each



Qual #.	Desc	Treats(gal.)	Cs
FP-00106	32 oz. Bottle	250	12
FP-00108	5 gal. Pail	5,000	1

### KILLEM

An oil soluble product, EPA approved as a biocide for the control of bacteria and fungi growth in oils and refined fuels. Killem will control microorganisms in fuel oil storage tanks, fuel oil and other refined or partially refined oils. Killem will reduce tank corrosion, slime mats, odors, fuel oil filter deposits and plugging, vehicle fuel tank deposits and corrosion, fuel-water separator deposits, injector plugging, excess carbon deposit and exhaust gas smoke. (-1)each



Qual #.	Desc	Treats(gal.)	Cs
FP-00119	16 oz.	1920	12

### GAS TREATMENT

Formulated to treat all grades of gasoline as well as gasohol. Totally dispersing water, Gas Treatment prevents carburetor icing and rusting in the system. It removes gums, carbon, and varnish from internal engine parts; causing improved combustion, greater acceleration, and increased mileage. Gas Treatment also eliminates rough idle, pre-ignition, and hesitation, without harm to catalytic converters. (-1) each



Qual #.	Desc	Treats(gal.)	Cs
FP-00189	12 oz. Bottle	30	12

### FUEL POWER

Compatible with all grades of fuel and can be used year round providing several benefits. Totally disperses water. Creates hydrogen polar bonding. Acts as a corrosion inhibitor. Cleans entire fuel injector system. Acts as a fuel stabilizer. Prevents icing in fuel. Controls bacteria growth. Controls waxing and gelling. Lubricates entire fuel system. Contains No Alcohols! Prevents formation of acids. Increases combustion for greater efficiency.

Qual #.	Desc	Treats(gal.)	Cs
FP-00100	8 oz. Bottle	240	24
FP-00102P	5 gal. Pail	19,200	1
FP-00103	55 gal. Drum	211,200	1



### FUEL POWER PLUS LUBRICITY

A year round diesel fuel treatment that combines the benefits of Fuel Power and a lubricity additive that exceeds the A.S.T.M. B.O.C.L.E. standards. Contains Fuel Power. Helps prevent piston fuel pump wear. Contains lubricity additive. Reduces pindle scoring. Contains No Alcohols! Helps prevent rotary fuel pump wear. Improves engine starting. (-1) each



Qual #.	Desc	Treats(gal.)	Cs
FP-00105	32 oz. Bottle	250	12

### FPPF'S ABC - AIR BRAKE CONDITIONER

Qual #: 11819

Protects all air brake systems and helps prevent freeze-ups. There are no ingredients or residues to corrode brake line systems. ABC contains pure methanol. 12(32oz) ea (-1)



### OCTANE BOOSTER

Specially formulated to raise low octane fuels up to 5+ points, clean fuel injectors and carburetors, and provide increased power and acceleration. OCTANE BOOSTER contains no harmful alcohols, no carcinogens and will not produce harmful organic metal deposits. OCTANE BOOSTER can be used with any grade of gasoline including leaded and unleaded gas.

Qual #.	Desc	Treats(gal.)	Cs
FP-00140	12 oz. Bottle	30	12





## FPPF Products

### MARINE DIESEL FORMULA

95% of all diesel fuel problems are water related. Condensation forms in fuel daily, all year long causing injector failure, waxing and gelling, bacteria growth, and the formation of sulfuric acid. MARINE DIESEL FORMULA totally disperses water and prevents these problems from occurring in your system. It decarbonizes, cleans and lubricates the injection system, gives greater power, improves fuel economy and provides easier starting in all types of weather. This formulation is ideal for fuel stabilizing during winter storage. (-1) each



Qual #.	Desc	Treats(gal.)	Cs
FP-00165	16 oz. Bottle	240	12

### BIG RED MULTIPURPOSE RED GREASE

A remarkable, highly efficient non-chlorinated lubricant in an easy to use spray can. This product sprays out as a thin, penetrating liquid and sets as a thick, red grease. The grease withstands temperatures to 500°F and resists "throw-off" from moving parts. Included in the formula are additives for antirust, anti-wear, oxidation and for water and acid resistance. Cs/12 (-1) ea



Qual #. FP-00125, FP-00125-I

### TOTAL POWER

The Ultimate Winter Diesel Treatment Total Power is a combination of the technology of Fuel Power, Polar Power, Diesel Injector Cleaner, Cetane 8+, and includes a lubricity additive. Benefits are: Lowers CFPP. Contains anti-gel. Lowers pour point. Cleans injectors. Raises cetane. Meets L-10. Meets A.S.T.M. B.O.C.L.E. Meets N-14. Contains No Alcohols!



Qual #.	Desc	Treats(gal.)
FP-00343 (-1)	32 oz cs(12)	250
FP-00344	5 gal	5000

### OCTANE BOOSTER

Specially formulated to raise low octane fuels up to 5+ points, clean fuel injectors and carburetors, and provide increased power and acceleration. Octane Booster contains no harmful alcohols, no carcinogens and will not produce harmful organic metal deposits. Octane Booster can be used with any grade of gasoline including leaded and unleaded gas. Cs/12 (-1) ea



Qual #. FP-00140, FP-00140-I 12oz.

### 4000 COOLING SYSTEM TREATMENT

A concentrate utilizing today's technology to create a combination corrosion inhibitor and scale dispersant specifically designed to maintain heat transfer in all closed cooling systems. This product contains anionic polymers, surfactants, molybdenum and more to provide protection to all types of metals, including aluminum. By removing the existing scale, eliminating foaming, and reducing cavitation, 4000 improves the efficiency, decreases the potential for overheating and extends the engine life. It is non-toxic, non-corrosive, and will not affect gaskets and hoses. Our quality cooling system treatment is compatible with all types of antifreeze including Glyclean. (-1) each



Qual #.	Desc	Treats(gal.)	Cs
FP-00149	16 oz. Bottle	8	12

### TRUCK WASH

A concentrated truck and trailer wash and cleaner designed to remove all types of grime, dirt, road film and grease. This product rinses quickly and does not water spot. Truck Wash is safe for use on all painted, fiberglass-reinforced plastic, aluminum and stainless steel finishes and will not harm rubber, glass or plastic.



Qual #. FP-00361	1 gallon	cs/4
Qual #. FP-00361-I	(-1) ea	
Qual #. FP-00362	5 gallon	each

### 8 PLUS CETANE

Improves Diesel engines function on the principle of Auto Ignition. The range of temperatures varies from 410°F to over 1040°F, this wide range is due to lower cetane numbers. 8 Plus Cetane Improver will raise the cetane level of your fuel providing faster starting, reduced engine noise, reduced smoke and particulates, and increased power and acceleration.



Qual #. FP-00188	32 oz.	Cs/12
------------------	--------	-------

### SLUDGE BE GONE

Formulated to eliminate sludge and water. SBG's specially formulated chemical base dissolves the sludge into a combustible substance in such a way as not to clog nozzles, while assuring clean filters and strainers. Helps to improve atomization and will provide a more efficient combustion. Effective in #1, 2, 4, 5 and 6 fuels. ea(-1)



Qual #. FP-00342	32 oz. Bottle
------------------	---------------

Treats 1000gal

## FPPF Power Team Performance Features

Item	Fuel Power	Fuel Power + Lubricity	Diesel Injection Cleaner	Polar Power	Total Power	Melt Down	8+ Cetane Improver	Killem
Water Dispersant	*	*	*	*	*	*		
Hydrogen Polar Bonding	*	*	*	*	*			
Cleans Injectors	*	*	*	*	*			
Removes Gum & Vanish	*	*	*	*	*	*		
Decarbonizes Combustion Chamber	*	*	*	*	*	*		
Increases Combustion	*	*	*	*	*	*	*	
Greater Engine Efficiency	*	*	*	*	*	*	*	
More Power	*	*	*	*	*		*	
Increased Fuel Economy	*	*	*	*	*			
Corrosion Inhibitor	*	*	*	*	*			
Controls Icing & Gelling	*	*	*	*	*	*		
Surface Tension Reducer	*	*	*	*	*			
Fuel Stabilizer	*	*	*	*	*			
Controls Bacteria Growth	*	*	*	*	*			*
Item	Fuel Power	Fuel Power + Lubricity	Diesel Injection Cleaner	Polar Power	Total Power	Melt Down	8+ Cetane Improver	Killem
Prevents Formation of Acids	*	*	*	*	*			
100% Soluble in all Fuel Oils	*	*	*	*	*	*	*	*
Alcohol Free	*	*	*	*	*		*	*
Lubricates Entire Fuel System	*	*	*	*	*			
Lubricant (Meets B.O.C.L.E.)		*			*			
Detergent (Meets L-10)			*		*			
Corrosion Inhibitor (Meets N-14)			*		*			
Pour Point Depressant				*	*			
Lowers Cold Filter Plug Point				*	*			
Seed Crystal Modifier				*	*			
Wax Dispersant				*	*	*		
Cetane Improver					*		*	
Raises Cetane Up to 8 Points							*	
Re-liquifies Gelled Fuel						*		
EPA Approved Biocide								*

## Miscellaneous Chemicals, Greases, Compounds

Qual #	Item	Quantity
801	Vandal Mark Remover	cs/12
11797	Cutting & Tapping Fluid	cs/6
11798	Fluid Film	cs/12 ea/-1
11798-5	Fluid Film	5 Gal.
11799	Marvel Mystery Oil	cs/12 ea/-1
11807	Marvel Air Tool Oil	cs/12
11825	DU-OL Non-flammable penetrating fluid Stop squeaks Preserves rubber	cs/24 (-1) ea
11834	Hydraulic "Jack" Oil	Cs/6 ea/-1
11835	Hydraulic "Jack" Oil	5 Gal.
11895	CAMIII 80-90W Gear Oil	5 Gal.
11811	Brake Clean Qual	cs/12 ea/-1
11838	Brake Fluid/ 5Gallon	each
11840	Brake Fluid/ Gallon	Cs/6
11841	Brake Fluid/ 12 oz.	cs/24 ea/-1
11845	Power Steering Fluid	24/12oz (-1)
11845-12	P/S Fluid	12/12oz (-1)
11845-32	P/S Fluid	12/32oz (-1)
11087	Fast-Tack Adhesive	cs/12

Qual #	Item	Quantity
11801	All Purpose Foaming Cleaner	cs/12 ea/-1
11815	Lock De-icer	cs/24 ea/-1
11821-AF	Glass Cleaner (ammonia free)	cs/12
11822	Bars Leak	cs/12
11836	Dry Gas	cs/24 ea/-1
11837	Windshield Washer	cs/24 ea/-1
11837-G	Windshield Washer /5Gallon	Cs/6
11837-D	Windshield Washer w/deicer	Cs/6 gal
11876	Ice Melt 45lb. (KCL)	each
11826	Ice Melt 50lb. (KCL)	each
11880	MELT-ICE 50LB. (NACL)	each
11849	Speedy Dry 40 lb.	each
11847	Dextron Transmission Fluid	cs/12 ea/-1
11860	Armorall	cs/12
11860-1	Armorall/ 28oz	each
11899	Greze Off /32 oz	Cs/12
65740	ChevronTechron Fuel System Cleaner 20oz.	Cs/6
Z11900	Freon-R134/ 30 lb.	each

### BATTERY TERMINAL CLEANER

#### ARM & HAMMER BAKING SODA

Qual #: 11813 cs/8  
Neutralizes acid and cleans deposits on terminals

#### DEKA BATTERY CLEANER

Qual #: 11824, 11824-1  
Cs/12, (-1) ea  
Penetrates, loosens and neutralizes all acid corrosion deposits 15oz. Aerosol.

#### BATTERY TERMINAL PROTECTION

Deka Battery Terminal Protection, Fights corrosion. Prolongs battery life, 15oz. Aerosol Can  
Qual #: 11823 Cs/12  
Qual #: 11823-1 (-1) ea

#### UNIFIDE WHITE LITHIUM GREASE

For automotive & marine use. Prevents rust. Will not wash out. Extends Lubrication periods.

Qual #: 11814 cs/12  
Qual #: 11814-1 (-1) ea

#### CARBURETOR CLEANER 2+2 GUM CUTTER

Concentrated cleaner cleans carburetor and metal parts Safe for use with catalytic converters & sensors, 13oz. Aerosol

Qual #: 11816 Cs/12  
Qual #: 11816-1 (-1) ea

#### BLASTER PENETRANT

Rust, corrosion, sticking, and squeaking problems are eliminated. Remains on the surface as a lubricant and rust inhibitor.

Qual #: 1051B Cs/12  
Qual #: 1051B-1 (-1) ea

#### AFTA CLEANING FLUID

Adhesive remover and cleaning solvent

AF-4003 cs/ 12  
AF-4003-1 each pint  
AF-4060 cs/6  
AF-4060-1 each Gal  
AF-4007 Drum

#### SYNTHETIC RESIN PLASTIC TYPE AUTO BODY SEALER

Qual #: Au-1001

Natural, cs/ 10 tubes

For use as a water and dust seal on exterior and interior body surfaces. Can be air dried or baked and painted with lacquer or enamel immediately after application. Fits standard caulking gun.

#### YELLOW SILICONE

Qual #: 11133 cs/12

Intended for use as a sealant for bonding to non-porous surfaces. Forms a long lasting seal that is unaffected by sunlight, rain, snow, ozone, ultraviolet radiation and temperature extremes.

#### BLACK SILICONE WHITE SILICONE

Qual #: 11131 cs/12 Qual #: 11134 cs/12

#### WD-40

Loosens rusted parts. Displaces moisture. Stops squeaks. Protects Metal from corrosive elements. Removes tar, grease, adhesives

Qual #: WD-10108 8oz., Cs/12, (-1) ea  
Qual #: WD-10110 Gal each

#### 3M HIGH POWER SPRAY BRAKE CLEAN

Qual #: MMM-08880 cs/12

Non-chlorinated general-purpose degreaser. Contains no ozone depleting ingredients

#### LIQUID ELECTRIC TAPE

Qual #: M-218

4 oz can of vinyl dielectric liquid for use on connections & terminals. Protective properties resist moisture, acids & corrosion.

#### LUBRIPLATE 105

Qual #: 11800 cs/12 10oz. Tube  
Motor Assembly Grease

#### LUBRIPLATE 1200-2 GREASE

Qual #: 11812 cs/10

Heavy duty multi-purpose grease for industrial and automotive uses.

#### LUBRIPLATE WHITE LUBE CARTRIDGE

Qual #: 5906 cs/10 (-1) ea

#### COOL-TOOL

Drilling, tapping & cutting oil, Lubricates cutting tools. Reduces heat & friction. Eases all machine operations

Qual #: BK-360 Cs/12  
Qual #: BK-360-1 (-1) ea

#### SUPER LUBE DRI-FILM

A self-cleaning lubricant that actually cleans while lubricating. Dri-Lube leaves behind a protective shield lubricant that will not attract dust. The dry coating provides a low coefficient of friction which gives excellent lubrication and release properties.

Qual #: Sup-11016 cs/12  
Qual #: Sup-11016-1 each

#### SUPER LUBE AIR TOOL LUBRICANT

Fits needs of industrial, household, and agricultural tool uses. Blended rust and corrosion inhibitors and a special base fluid oil minimizes wear and allows operation of air tools at temp. as low as -40°, 4 oz. Bottle

Qual #: Sup-12004 cs/ 6  
Qual #: Sup-12004-1 each

#### SUPER LUBE

Long lasting, penetrating lubricant. Clear synthetic compound with Teflon. Excellent adhesion, will not drip or run. Prevents rust & corrosion. Reduces friction, repels dirt and water. Safe on rubber, plastics & plants.

Qual #	#Ea.	Size	Cs	Qual #	#Ea.	Size	Cs
Sup-31041	-1	4-1/2 oz. Aerosol	12	Sup-41051		5 lb. Can	1
Sup-31111	-1	11 oz. Aerosol	12	Sup-41031		30 lb. Can	1
Sup-21031	-1	3 oz. Tube	12	Sup-41120		120 lb. Drum	1
Sup-41161	-1	16 oz. Tub	12	Sup-41140		100 lb. Drum	1
Sup-41151	-1	14-1/2 oz. Ctrg	12	Sup-51011	-1	1/4 oz. oiler	12

## Paint

### KRYLON INDUSTRIAL

#### CASE / 6 OR (-1) EACH

Qual #	Color
KRY-1501	Glossy White
KRY-1601	Glossy Black
KRY-1613	Semi Flat Black



#### CASE / 6

Qual #	Color
BT40	Gloss White Enamel
BT42	Gloss Black Enamel
BT43	Flat Black
BT49	Gray Primer
BT51	Red Primer

S-153 School Bus Yellow

TA4	Black
TA5	White

### PLASTI-KOTE



#### CASE / 6 OR (-1) EACH

Qual #	Color	Qual #	Color
PLA-208	Pontiac Blue	PLA-T6	Swift Red
PLA-224	Ford Blue	PLA-T8	Satin Black
PLA-225	Alpine-green	PLA-T10	Machinery Gray
PLA-233	Beige	PLA-T12	Shamrock Green
PLA-235	Gray Sand Primer	PLA-T16	Royal Blue
PLA-364	Dove Gray	PLA-T18	Gray Metal Primer
PLA-615	Bumper Chrome	PLA-T19	Red Oxide Primer
PLA-1355	New Cat Yellow	PLA-T23	Hi-temp Aluminum
PLA-1356	Cat Yellow	PLA-T24	Flat White
PLA-HP11	Ultra H.h.black	PLA-T27	Antique White
PLA-HP14	Ultra H.h Alum.	PLA-T29	School Bus Yellow
PLA-T1	Gloss Black	PLA-T37	Federal Gray
PLA-T2	Flat Black	PLA-T43	Dark Cherry
PLA-T4	Gloss White		

### ALLIGATOR CLAMPS

Qual #: 20105 10/ Pkg



Qual #: 20108 5/ Pkg  
25 AMP



Qual #: 20107 10/ Pkg  
10 AMP



Qual #: 20109 5/ Pkg  
50AMP



### EXTRA HEAVY DUTY PARROT TYPE CLAMP

Qual #: 5100 Pkg 1 Pair



### BATTERY CLAMP

Qual #: 20110  
Skin Pkg 1 Pair



### BOOSTER CABLE SETS

Arctic Twin-Line Booster Cables are constructed with fine stranded flexible copper for ease of use, and are unitized to make them virtually insulation is resistant to destructive acids, gasoline, grease, abrasion and temperature extremes. Designed to fit both top-post and side-mount batteries, the 400 AMP clamps are color coded with chip-proof vinyl insulation.

Qual #: 5107 20'  
Qual #: 5109 12'  
Qual #: 5110 Clamp



## Miscellaneous Hand Tools

### LOCK CLIP TOOL

Qual #: 34778

Removes inside Handles without loss of horseshoe clip. Clip remains in handle. GM



### CIRCUIT TESTER

Qual #: 20121  
(Power On)

TESTS FOR SHORTS IN Ground circuit of all lamps, fuses, wiring relays, radio, antenna armature & brush holder. Breaks in wiring bulbs, Wire connectors Field coils, switches Battery cable circuits Head, tail, stop and dome lights.



### ALL PURPOSE SCRAPER AND INSPECTION STICKER REMOVER

Qual #: 20120

Effectively removes inspection stickers, especially on late model cars with slanting windshields and protruding dash panels. Also handy as paint scraper varnish scraper, etc. Locks into 3 positions for effectiveness in difficult to reach areas. Cutting end folds up into protective position for safe storage.



### ALL PURPOSE SCRAPER

Qual #: 20126

Blade 8" long, 1" wide. Heat-treated with single chisel edge. Plastic handle. For cleaning, scraping heads and pistons; can be used as chisel for cutting wood or light metals.



# Tire Valves, Extensions, Cores & Caps

## VALVES

Bx 10 or (-G) Bx 25

Rubber cover- not affected by heat or cold. Inspected Valve core- accurate. Tubeless-rubber covered snap-in type Heavy knurled plastic cap. Airtight fit- precision molded.

Qual #: 14004

For 14", 15" Rims with .453 Rim Hole. Valve Length 1-1/4"



Qual #: 14005

For 14" Rims with .453 Rim Hole. Valve Length 2"

Qual #: 14001

For 14", 15" Rims with 5/8 Rim Hole. Valve Length 1-1/2"



Qual #: 14002

For 14", 15" Rims with 5/8 Rim Hole. Valve Length 2"



## VALVES

### METAL

Qual #: 14009 Bx 5  
5/8" rim hole. Length 1-1/2"

### X-LONG

Qual #: 14008 Bx 10

### STEM LOCK

Qual #: 14015 Bx 10

### CHROME SLEEVE VALVE

Qual #: 14003 Bx 10  
.453 Rim Hole. Valve Length 1-1/4"



### TUBELESS TRUCK VALVES FOR DROP CENTER RIMS

Both demountable and non-demountable rims with 5/8" rim hole. Bx 5  
Qual #: 14007 Length 2"  
Qual #: 14007-L Length 3-3/4"



## VALVE EXTENSIONS

100% special Nylon material eliminates rattle of wheel covers



Qual # Valve Length

M-113-S 3/4"

M-113 1-1/4"

M-113-L 1-7/8"

M-113-XL 2-3/8"

## VALVE CAPS - CORE

Qual #: 14010 Bx 25  
Deep Slotted Brass



Qual #: 14011 Bx 25  
Flat Top Brass



## SHORT VALVE CORE

Qual #: 14013 Bx 25



## PLASTIC CAP

Qual #: 14012 Bx 50



## TUBE/ TUBELESS TIRE REPAIR PATCHES

### ROUND

Qual#	Size	Bx
M-146-1	1-1/2"	40
M-146-2	2"	30
M-146-2.5	2-1/2"	30
M-146-3	3"	20



### OVAL

Qual#	Size	Bx
M-146-4	1-5/8X3	20
M-146-5	2-1/8X4-1/2	10



## GAUGES

### SERVICE GAUGE

Qual #: M-149  
Calibrated 10-160 lbs. Easy to read round metal bar. Triple-chromed with Lanyard Ring



### CALIBRATED

Qual #: M-150-A  
14-160 lbs.



### OFFSET DEEP HEAD, POCKET GAUGE

Qual #: M-147  
Calibrated 6-50 lbs. Easy to read round metal bar. Triple-chromed with pocket clip.



### TREAD DEPTH GAUGE POCKET TYPE

Qual #: M-153  
Calibrated 0.32-32" in 1/32" units



## CHEMICAL ACTIVATOR & CEMENT

A special patching method is recommended for radial, bias-belted, and steel belted tires. A vulcanizing insert seals cored ends, prevents "wicking" of the cords, and eliminates the possibility of dirt working into the injury. A chemical vulcanizing patch completes the job, making an effective repair. Complete instructions for use are included in each kit.

### ALL PURPOSE CEMENT

Qual #: M-144-8 1/2 pt. Can  
Use with Jiffy-patches, multi-plugs, dual-plugs, heavy duty patches, and cross type boots.



### ALL PURPOSE CHEMICAL ACTIVATOR

Qual #: M-145 1/2 pt. Can  
Use with Magi-Cure patches and Radial Tire patches



## COMBINATION VALVE & FISHING TOOL

Qual #: M-116

Draws valve stem in position when mounting tire. Handle has core remover & tube deflator. Made from strong flexible steel cable.



### NEEDLE TIRE KIT

Qual #: M-162-102

### TIRE KIT REFILL

Qual #: M-163

### LUBE TIRE KIT

Qual #: M-162-103

### REAMER TIRE KIT

Qual #: M-162-104

## Original Safety Seal



### REPAIRING TRUCK TIRES

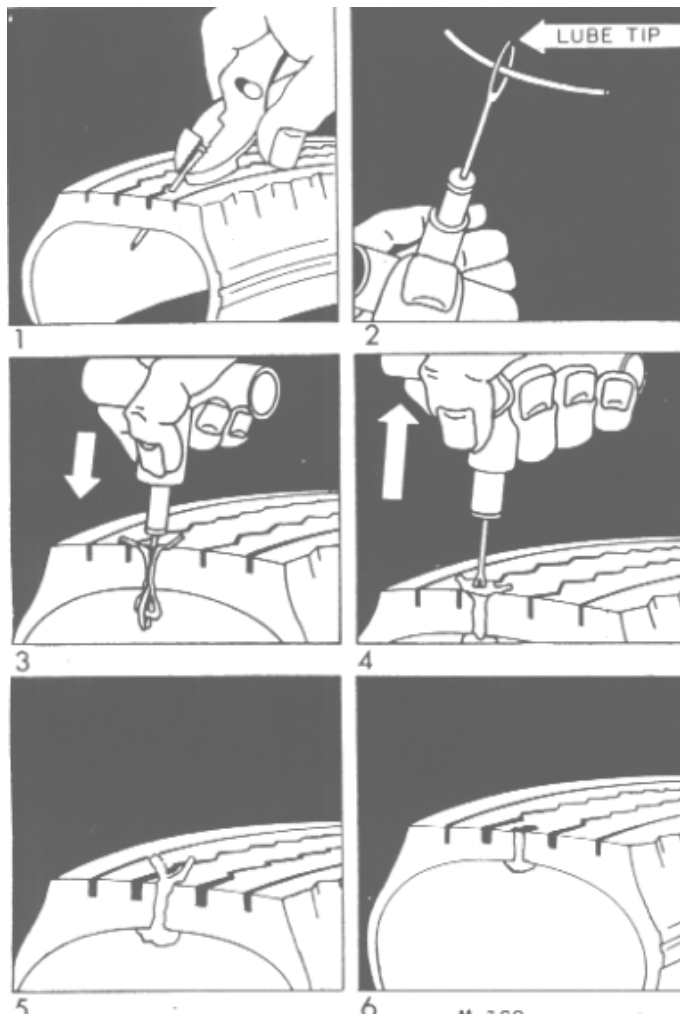

### REPAIRING STEEL BELTED TIRES

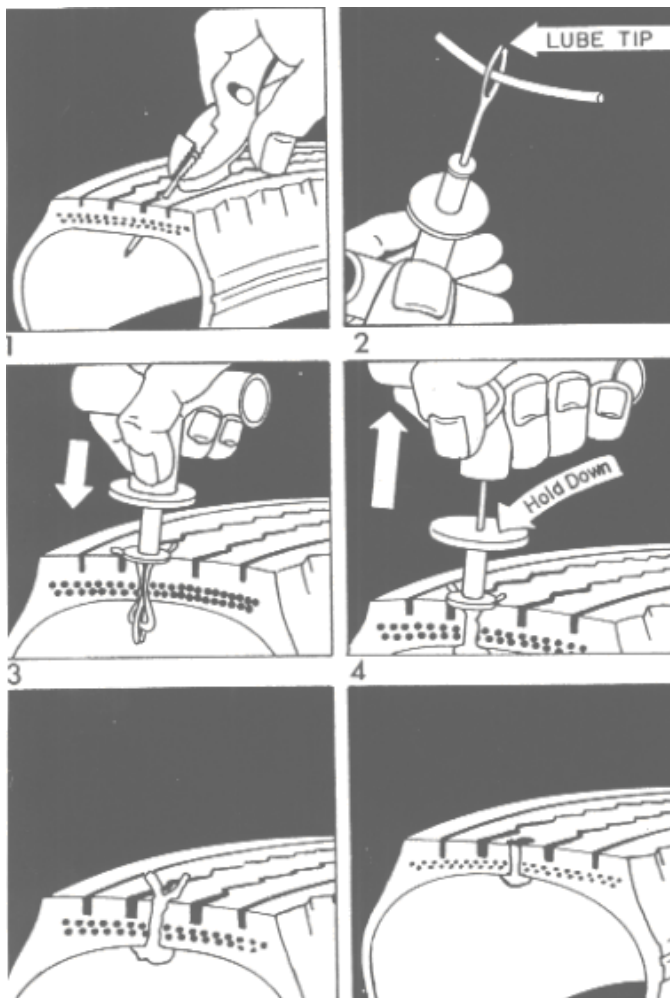

1. Carefully remove foreign object from tire and observe path of perforation. If puncture path difficult to find, wet tip of needle with LUBE and insert needle without the repair cord.
2. Having found path of puncture, thread insert needle with Safety Seal as shown.
3. On small, tight punctures, dip the tip of needle in LUBE before inserting. On larger holes and cuts, Lube not needed. Push firmly into tire as far as possible.
4. Retract needle with a slow, steady pull until Safety Seal® frees itself from eyelet of needle
5. Cut off excess repair material flush with tire.
6. Use cut off material to clean needle. This will make the next job easier.

#### Qual #: M-162

Full Kit Includes 30 Repairs, Professional Heavy Duty T-Handle Probe, T-Handle Insertion Tool and Lube.



1. Follow instructions as noted
3. Push Safety Seal® into the hole, using slow, steady pressure. Turn needle so that flat portion enters between steel wires shown. Do not use excessive force that will bend the needle. Rather, use a reamer to open the hole slightly to accommodate the repair.
4. Hold sleeve firmly against tire with one hand until needle is free of the safety seal repair cord
5. & 6. Follow instructions as noted



# Perma-Coil

## Helically Coiled Inserts And Thread Repair Kits



### INCH SERIES- COARSE

REPAIR KITS*			REPLACEMENT PARTS				
Thread Size	Repair Kit Part #	Inserts / Pack	Kit Tool	Kit Tap	Packaged** Inserts	Qty. Inserts	Drill Size
4-40	1208-014	12	1172-014	1428-014	208-014	12	1/8
5-40	1208-015	12	1172-015	1428-015	208-015	12	9/64
6-32	1208-016	12	1182-016	1428-016	208-016	12	5/32
8-32	1208-018	12	1182-018	1428-018	208-018	12	11/64
10-24	1208-101	12	1182-101	1428-101	208-101	12	13/64
12-24	1208-102	12	1182-102	1428-102	208-102	12	15/64
1/4-20	1208-104	12	1182-104	1428-104	208-104	12	17/64
5/16-18	1208-105	12	1182-105	1428-105	208-105	12	21/64
3/8-16	1208-106	12	1182-106	1428-106	208-106	12	25/64
7/16-14	1208-107	6	1182-107	1428-107	208-107	6	29/64
1/2-13	1208-108	6	1182-108	1428-108	208-108	6	17/32
9/16-12	1208-109	6	1182-109	1428-109	208-109	6	19/32
5/8-11	1208-110	6	1182-110	1428-110	208-110	6	21/32
3/4-10	1208-112	4	1182-112	1428-112	208-112	4	25/32
7/8-9	3208-C14	6	1182-114	1043-14CP3	108-114	1	29/32
1-8	3208-C16	6	1182-116	1043-16CP3	108-116	1	1-1/32

### INCH SERIES-FINE

REPAIR KITS*			REPLACEMENT PARTS				
Thread Size	Repair Kit Part #	Inserts / Pack	Kit Tool	Kit Tap	Packaged** Inserts	Qty. Inserts	Drill Size
10-32	1208-201	12	1172-201	1428-201	208-201	12	13/64
1/4-28	1208-204	12	1172-204	1428-204	208-204	12	17/64
5/16-24	1208-205	12	1172-205	1428-205	208-205	12	21/64
3/8-24	1208-206	12	1172-206	1428-206	208-206	12	25/64
7/16-20	1208-207	6	1172-207	1428-207	208-207	6	29/64
1/2-20	1208-208	6	1172-208	1428-208	208-208	6	33/64
5/8-18	1208-210	6	1172-210	1428-210	208-210	6	41/64
3/4-16	1208-212	4	1172-212	1428-212	208-212	4	49/64
7/8-14	3208-F14	6	1039-14F	1043-14FP3	108-214	1	57/64
1-14	3208-F164	6	1039-164F	1043-164FP3	108-2164	1	1-1/64

\*\* Perma-coil insert packs contain inserts only.

The above packs and insert bags contain inserts whose length is 1-1/2 times their diameter.  
(For example, the 1/4-20 insert is 3/8" long.) Other sizes and lengths available.

\*Perma-coil repair kits include: Inserts, Installation Tool, and Tap

### METRIC SERIES-COURSE

REPAIR KITS*			REPLACEMENT PARTS				
Thread Size	Repair Kit Part #	Inserts / Pack	Kit Tool	Kit Tap	Packaged** Inserts	Qty. Inserts	Drill Size
M5x0.8	1221-305	12	1287-305	1448-305	206-305	12	13/64
M6x1	1221-306	12	1287-306	1448-306	206-306	12	1/4
M8x1.25	1221-308	12	1289-308	1448-308	206-308	12	21/64
M10x1.5	1221-310	12	1289-310	1448-310	206-310	12	13/32
M12x1.75	3221-M12C	6	1289-312	5043-120CP4	106-312	6	31/64

### METRIC SERIES-FINE

REPAIR KITS*			REPLACEMENT PARTS				
Thread Size	Repair Kit Part #	Inserts / Pack	Kit Tool	Kit Tap	Packaged** Inserts	Qty. Inserts	Drill Size
M10x1.25	3221-M10F	12	1287-610	5043-100FP4	106-610	12	13/32
M12x1.25	3221-M12F	6	1287-612	5043-120FP4	106-612	6	31/64

### SPARK PLUG REPAIR KIT

Size	Kit P/N	Reach	Insert /kit	Tap P/N	Tool P/N	Reach	Insert Pkg P/N	Qty
M14-1.25	2200-14	SHORT	1	2258-14	2294-14	SHORT		
M14-1.25	2200-14	NORMAL	1	2258-14	2294-14	NORMAL	2214-N	1
M14-1.25	2200-14	LONG	1	2258-14	2294-14	LONG		

**ROSIN OR ACID CORE SOLDER**

Qual #	Type
M-1093	1lb. Rosin Core 40/60
M-1094	1lb. Acid Core 40/60
M-1095	5lbs Acid Core 40/60
M-1096	5lbs Rosin Core 40/60

**1 lb & 5 lb**



Qual #: M-1097  
4oz. THIN Rosin Core 40/60



Qual #: M-1090  
4 oz. .062 dia. 60/40 Rosin Core



**SAFETY BLOW GUNS**

Meets all OSHA standards  
Standard Safety Model. Safe when dead ended to below  
30 PSI danger limit. Valve lever control. Venturi action  
boosts air volume. Competitively priced



Qual #: M-118-600-S  
Qual #: M-118-606-S w/ 6" Extension



**DIRECT AIR LINE CHUCKS**

Qual #: M-115  
Single Foot Chuck. 1/4" Female NPT thread



Qual #: M-114  
Dual Foot Chuck. 1/4" Female NPT thread



Qual #: M-126 Snap-On Chuck Clip



**CUSTOM AIR HOSE**

Qual #	Size	Configuration
2105	1/4x 25'	04U-104 ftg w/ H11504 hose
2106	1/4x 50'	04U-104 ftg w/ H11504 hose
2107	3/8 x 25'	06U-104 ftg w/ H11506 hose
2108	3/8 x 50'	06U-104 ftg w/ H11506 hose
2109	1/2x 50'	08U-106 ftg w/ H11508 hose



**NON-KINK SERVICE STATION AIR HOSE**

2 Ply, 300 Lb. Working pressure. Supplied with 1/4" Male Pipe Fittings

Qual #: M-129 1/4" I.D. x 25'  
Qual #: M-130 1/4" I.D. x 50'

Qual #: M-129-3/8 3/8 I.D. x 25'  
Qual #: M-130-3/8 3/8 I.D. x 50'

**AIR HOSE PARTS**

Qual #: M-125  
Brass 1/4" Hose End  
1/4" Male Pipe Thread



Qual #: M-125-3/8  
Brass 3/8" Hose End  
1/4" Male Pipe Thread



Qual #: M-124  
1/4" Air Hose Splice



Qual #: M-124-X  
Brass 1/4" Hose  
Union



Qual #: M-124-3/8  
Brass 3/8" Hose  
Union



Qual #: M-123  
Qual #: M-123-3/8 fits 3/8 hose  
Heavy Duty Brass Hose End. 1/4"  
Hose End, 1/4" Male Pipe Thread



**COIL TUBE WITH FITTINGS**

Coil Tube is a lightweight, permanently coiled, flexible nylon air tube with maximum working pressure up to 200 psi. Operates all types of portable mechanical hand air tools with maximum dependability & efficiency. Retracts to its original shape. Ends protected by steel spring guard.

Qual #	Size
M-131	1/4" I.D. x 25' hose
M-132	1/4" I.D. x 50' hose
M-131-B	3/8" I.D. x 25' hose
M-131-C	3/8" I.D. x 50' hose



**CONTROL 2 WAY VALVE**

Qual #: M-117

For air, fluid, and vacuum lines. Female 1/4" NPT inlet and 1/4" NPT outlet. Max working pressure: 150 PSI. Perfect for tire changing machines



**GENERAL USE WATER HOSE**

Qual #	Size
1998	5/8 x 50' Garden Hose
1999	3/4 x 50' Garden Hose
2000	5/8 x 50' Contract Hose
2001	3/4 x 50' Contract Hose
2005	Quick Disconnect Hose Coupler
2006	H.D. Water Nozzle

# Tomco

Tomco Has Interchanges For 97% Of All Couplers

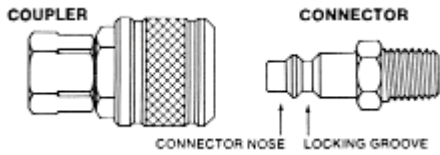

The coupler type is identified by the connector style. Key features are the length of the nose, and the type of locking groove. The 6 most commonly used styles are:

## GAUGE CHART

(Actual size profiles for identifying connectors)

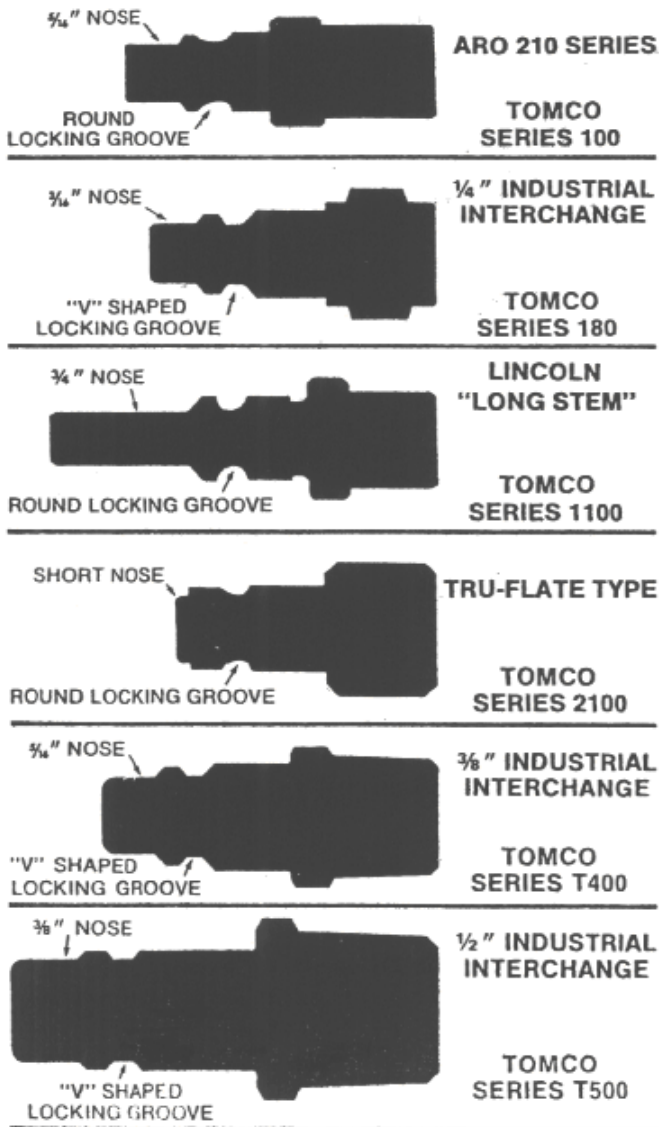

### SERIES 100

- Fully automatic-one hand coupling
- Affords up to 46 cfm at 100 p.S.I.G.
- Safe at pressures through 250 p.S.I.
- Operating temp. Range: -40°f. To +250°

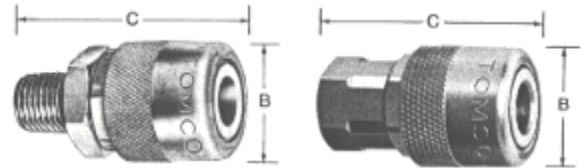

### COUPLERS

Qual#	Thread	B	C
M-136	1/4" Female NPT	1-1/16"	1-31/32"
	1/4" Male NPT	1-1/16"	1-5/8"

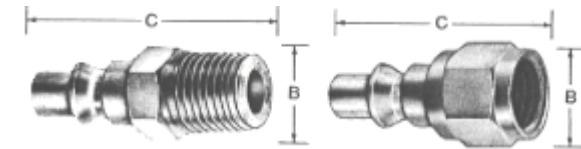

### CONNECTORS

Qual#	Thread	B	C
M-137	1/4" Male NPT	9/16"	1-11/16"
M-137-A	1/4" Female NPT	5/8"	1-3/4"

### SERIES 180

- Fully automatic-one hand coupling
- Affords up to 52 cfm at 100 p.S.I.G.
- Safe at pressures through 250 p.S.I.
- Operating temp. Range: -40°f. To +250°

### COUPLERS

Qual#	Thread	B	C
M-133	1/4" Female NPT	1-1/16"	1-11/16"

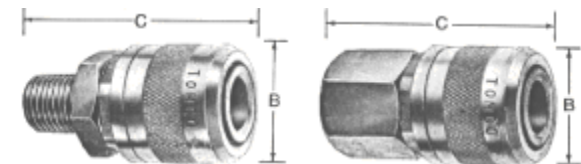

### CONNECTORS

Qual#	Thread	B	C
M-134	1/4" Male NPT	9/16"	1-25/32"
M-135	1/4" Female NPT	5/8"	1-9/16"

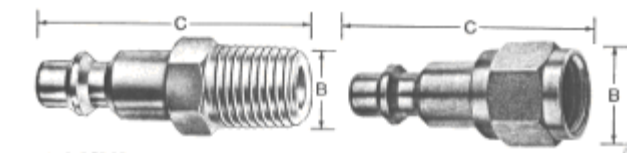

**SERIES I 100**

- Fully automatic-one hand coupling
- Affords up to 45 cfm at 100 p.S.I.G.
- Safe at pressures through 250 p.S.I.
- Operating temp. Range: -40°f. To +250°

**COUPLERS**

Qual#	Thread	B	C
M-139	1/4" Female NPT	1-1/16"	2-13/32"

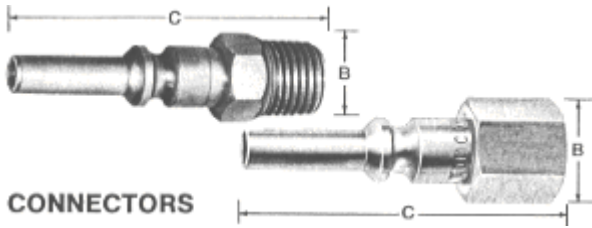
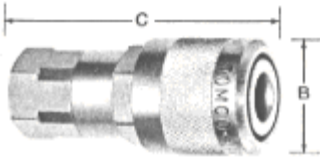

**CONNECTORS**

Qual#	Thread	B	C
M-140	1/4" Male NPT	9/16"	2-5/32"
M-141	1/4" Female NPT	5/8"	1-1/16"

**SERIES T 400**

- Semi-automatic – ball type
- Affords up to 75 cfm at 100 p.S.I.G.
- Operating temp. Range: -40°f. To +250°

**COUPLERS**

Qual#	Thread	B	C
M-151	3/8" Female NPT	1-1/8"	2-11/32"

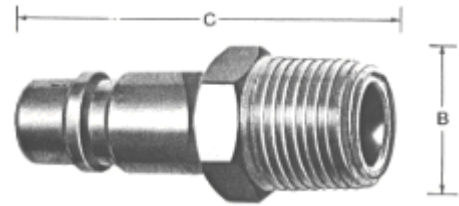
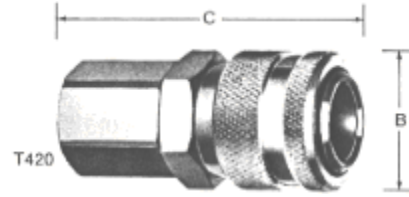

**CONNECTORS**

Qual#	Thread	B	C
M-152	3/8" Male NPT	11/16"	1-7/8"
M-152-A	3/8" Female NPT	11/16"	1-7/8"

**SERIES 2 100**

- Full swivel action
- Affords up to 45 cfm at 100 p.S.I.G.
- Safe at pressures through 250 p.S.I.
- Operating temp. Range: -40°f. To +250°

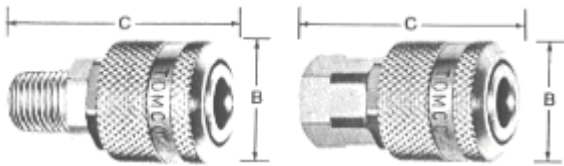

**COUPLERS**

Qual#	Thread	B	C
M-156	1/4" Female NPT	1-1/16"	1-7/8"

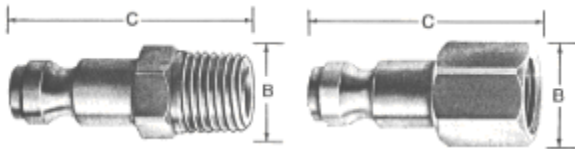

**CONNECTORS**

Qual#	Thread	B	C
M-157	1/4" Male NPT	9/16"	1-9/16"
M-158	1/4" Female NPT	5/8"	1-7/16"

**SERIES T 500**

- Semi-automatic – ball type
- Affords 160 cfm at 100 p.S.I.G.
- Operating temp. Range: -40°f. To +250°

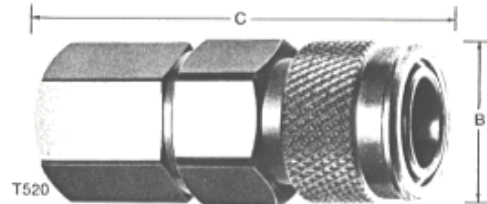

**COUPLERS**

Qual#	Thread	B	C
M-165	1/2" Female NPT	1-3/16"	3"

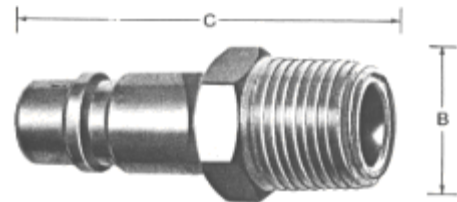

**CONNECTORS**

Qual#	Thread	B	C
M-166	1/2" Male NPT	7/8"	2-3/8"
M-167	1/2" Female NPT	7/8"	2-3/8"

**SAFETY BLOW GUN - SERIES 600**

Qual #: M-121

1/4" NPTF inlet

Most compact blow gun available. Easy thumb button operation. Machined from aluminum. Weighs only 2-1/2 ozs. OSHA approved sec. 1910.242(b)



**AIR ADJUSTING VALVE - SERIES 1200** (not shut-off valve)

Qual #: M-164

1/4" NPTF ports

Permits accurate flow control in either direction. Set knurled knob to desired flow rate. Spring-loaded ratchet permits positive flow adjustment without drift. Oil resistant seals prevent leakage.



**INTERCHANGE LIST**

	Tomco	Acme	Am. Parts	Amflo	ARO	Balkamp NAPA	Camel Bridgeport	Diamond "U"	Lincoln	Milton		Qual#
<b>Series 100 coupler</b>	100	A918B	9-690	AD-22,AE-22	210	4-820	-	1210	862	775	3526	M-136
	101	-	9-688	AD-02,AE-02	-	4-6600 4-6603	-	-	-	776	3525	N/A
<b>Series 100 connector</b>	200	A914N	9-683	AF-02	2608	4-821	-	1210MP	13329	777	3529	M-137
	300	A916N	9-685	AF-22	2609	4-822	-	1210FP	13331	778	3530	M-137-A
<b>Series 180 coupler</b>	181	A938B	9-711	HD-02, HE-02	23102-012	574	574	16MB	631004	716	5139-12	N/A
	184	A937B	9-712	HD-22, HE-22	23102-200	573	573	16FB	632004	715	5138-12	M-133
<b>Series 180 connector</b>	1804	A910N	9-706	HF-02	23902-210	4-6610	578	16MP	630104	727	5138-11	M-134
	1805	A911N	9-708	HF-22	23902-200	4-6611	579	16FP	630204	728	5139-11	M-135
<b>Series 1100 coupler</b>	1100	A935B	9-694	-	-	4-683	548	-	815	790	3528	M-139
<b>Series 1100 connector</b>	1109	A933N	9-696	-	-	4-693	550	-	11659	791	3531	M-140
	1110	A934N	9-698	-	-	4-695	551	-	11661	792	3532	M-141
<b>Series 2100 coupler</b>	2181	A926B	9-676	TD-02,TE-02	-	4-674	524	15T-MB	-	786	3503	N/A
	2184	A925B	9-677	TD-22,TE-22	-	4-675	523	15T-FB	-	785	3504	M-156
<b>Series 2100 connector</b>	2154	A928N	9-668	TF-02	-	4-685	538	15T-MP	-	783	3506	M-157
	2155	A929N	9-669	TF-22	-	4-686	539	15T-FP	-	784	3507	M-158
<b>Series T400 coupler</b>	T420	-	-	C-26	-	-	-	-	642006	1835	-	M-151
	T430	-	-	C-25	-	-	-	-	641006	1836	-	N/A
<b>Series T400 connector</b>	T43	-	-	CP-26	23903-300	-	-	-	640206	1838	-	M-152-A
	T42	-	-	CP-25	23903-310	-	-	-	640106	1837	-	M-152
<b>Series T500 coupler</b>	T520	942B	9-681	C-10	-	4-679	563	-	652008	1815	3512	M-165
	T530	-	9-680	C-9	-	4-678	564	-	651008	1816	3511	N/A
<b>Series T500 connector</b>	T55	-	-	CP-18	23904-400	-	-	-	650208	1858	-	M-167
	T54	-	-	CP-17	23914-410	-	-	-	650108	1857	-	M-166

**FD42 SERIES QUICK DISCONNECT COUPLING**

Designed for Hydraulic Systems & Snow Plow Applications

- 3000 psi maximum operating pressure
- cadmium plated steel construction
- proven ball latch mechanism
- non-checking poppet design
- can be bulkhead mounted
- withstands high surge flows
- Interchangeable with other couplings
- superior elastomeric poppet seals
- presentation of data conforms to NFPA/T3.20.2r1-1976

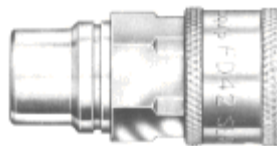

Qual #: M-171



Qual #: M-172

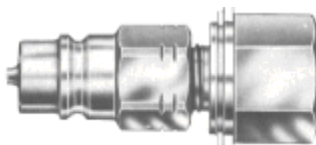

Qual #: M-173

Qual #: M-173  
Assembly Consists of:  
1 M-171  
1 M-172

The female coupling incorporates a retaining ring groove for bulkhead mounting and the addition of an inexpensive FFI607-0404S adapter makes bulkhead mounting of the male simple. For both female body and male adapter a 5100-87 Truarc retaining ring or equivalent should be used. A Teflon backup ring in front of the O-ring in the female half improves impulse life and acts as a wiper to clean the male half resulting in improved seal life.

## Tomco, Series St, Straight Through

Straight Through couplers are non-valved and are usually applied in liquid systems needing maximum flow with no restrictions. Some typical applications are in chemical processing, pressure wash, plastic mold coolant lines, on water manifolds, food processing and other liquid handling applications where shut-offs are not needed and full flow is advantageous

### PLUG

Qual #: M-185  
Male Pipe,  
Body Size: 3/8"  
Steel, Brass or 303 stainless

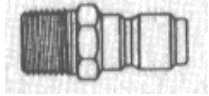

### PLUG

Qual #: M-184  
Female Pipe,  
Body Size: 3/8"  
Steel, Brass or 303 stainless



### COUPLER

Qual #:  
Male Pipe,  
Body Size: 3/8"  
Brass or 303 stainless



### COUPLER

Qual #: M-183  
Female Pipe,  
Body Size: 3/8"  
Brass or 303 stainless



## TRU-FLATE/PARKER STYLE INTERCHANGE SERIES

3/8" Basic Size

### COUPLER

Qual #	Type	NPT size
M-178	Female	1/4"
M-175	Female	3/8"

### PLUG

Qual #	Type	NPT size
M-179	Male	1/4"
M-180	Female	1/4"
M-176	Male	3/8"
M-177	Female	3/8"

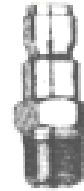

M-179  
M-176



M-180  
M-177



M-178  
M-175

## Heater Parts And Valves

### T SPLICER each

Qual #	Hs ID
C1718-10	5/8
C1718-12	3/4



### Y CONNECTOR each

Qual #	Hs ID
C1719-10	5/8
C1719-12	3/4



### HOSE SPLICER each

Qual #	Hs ID
C1720-8	1/2
C1720-10	5/8
C1720-12	3/4
C1720-16	1



### REDUCING HOSE SPLICER

each

Qual #	Hs ID
C1721-108	5/8 X 1/2
C1721-1210	3/4 X 5/8
C1721-1612	1 X 3/4



### HOSE TO PIPE NIPPLE- HEX FLAT

each

Qual #	Hs ID	Male P.T.
C1712-86	1/2	3/8
C1712-106	5/8	3/8
C1712-108	5/8	1/2
C1712-128	3/4	1/2



### IN-LINE HOSE TO HOSE HEATER VALVE

Qual #	Hs ID
C880-88	1/2 x 1/2
C880-1010	5/8 x 5/8
C880-1212	3/4 x 3/4
C880-1616	1 x 1



## Quick Changer Engine Oil Drain System For Heavy Duty Trucks

Engine	Model	Size	Part	Hose
<b>Allison</b>	AT 542 MT643 HT740 Transmission	1/2"-20 UNF	M-501	M-525
	B400 Md3060 HD4060	3/4"-16 UNF	M-502	M-525
<b>Carrier</b>	Kubota NDBN405	3/4"-14 NPT	M-506	M-526
<b>Caterpillar</b>	3304 3306 3406 3406B 3408 3412 3176	1-1/8"-12 UNF	M-509	M-526
	C10 C12 C15 C16	1-1/8"-12 UNF	M-509	M-526
	1100 1140 1145 1150 1160 3054 3056 3100	3/4"-16 UNF	M-502	M-525
	3114 3116 3126 3126B 3126E(before 2004) 3208 C9	3/4"-16 UNF	M-502	M-525
	3126E (2004+)	18mm-1.5	M-517	M-525
	3304 3306 992 B/C Series	1-1/2"-12 UNF	M-531	M-526
	Above engines w/optional Plug	1"-12 UNF	M-507	M-526
<b>Chevy/GMC</b>	Fits Engine with 12mm-1.75	12mm-1.75	M-513	M-525
	Fits Engine with 1/2"-20 UNF	1/2"-20 UNF	M-501	M-525
<b>Cummins</b>	4BT 6BT 6CPA C8.3 6CTA ISB ISC ISL	18mm-1.5	M-517	M-525
	L10 M11 N14 N855 ISM ISX 315 335 350 400	1"-18 UNF	M-508	M-526
	5.9L After '95 (Dodge)	22mm-1.5	M-519	M-525
	Signature 600 Series ISX QSX	27mm-2.0	M-523	M-526
<b>Detroit Diesel</b>	6-71TA 6-92TA 8-92TA	1/2"-14 NPT	M-500	M-525
	353 453N 453T 853 Series 50 & 60	3/4"-14 NPT	M-506	M-526
	40877100 40877300 (8.2L)	1/2"-20 UNF	M-501	M-525
	Series 40	7/8"-18 UNF	M-505	M-525
<b>Dodge</b>	Cummins 5.9L Diesel Engine	22mm-1.5	M-519	M-525
<b>Ford</b>	6.6L 7.8L 8.2L	3/4"-16 UNF	M-502	M-525
	FD 1060 FD 1460	18mm-1.5	M-517	M-525
	6.0L 7.3L Diesel Powerstroke (Int'l Engine)	14mm-1.25	M-514	M-525
	370 460 V10	14mm-1.5	M-515	M-525
	6.9L	1/2"-20 UNF	M-501	M-525
<b>International</b>	304 343 345 392 360 404 420 (6.9L) 446	1/2"-20 UNF	M-501	M-525
	DT408 DT466 Eng Before '94/'95	7/8"-18 UNF	M-505	M-525
	DT466 Eng 1994-2004 Series 530	25mm-1.5	M-521	M-526
	DT466 2005 & newer	18mm-1.5	M-517	M-525
	T444E Diesel VT365	14mm-1.25	M-514	M-525
<b>Isuzu</b>	4BD1 4BD2T 6BD1T 2X4 Pup Diesel	20mm-1.5	M-518	M-525
	NPR EFI (5.7L) GM Engine	1/2"-20 UNF	M-501	M-525
<b>Mack</b>	E3 E5 EC3 EC5 E6 EM6	7/8"-18 UNF	M-505	M-525
	E7 E427 CH613	20mm-1.5	M-518	M-525
<b>Mercedes</b>	Most Engines	26mm-1.5	M-522	M-526
<b>Thermo King</b>	Yanmar Engine	1/2"-14 NPT	M-500	M-525
	Isuzu & Mercedes Engines	3/4"-14 NPT	M-506	M-526
<b>Volvo</b>	F6 FE6 (Older Engine) F12	24mm-1.5	M-520	M-526
	F6 F7 N10 N12 F86	7/8"-14 UNF	M-504	M-525



## Quick Changer Engine Oil Drain System For Cars & Light Trucks

Engine	Model	Size	Part	Hose
<b>Acura</b>	All	14mm-1.5	M-515	M-525
<b>AMC</b>	1967-Present, All V8 Eng., All V6 Eng. 4 Cylinder 121 Engines 1981-83 2.5L (151) Engines 2.1L Diesel Engines	1/2" - 20 UNF 14mm -1.5 12mm -1.75 16mm -1.5	M-501 M-515 M-513 M-516	M-525 M-525 M-525 M-525
<b>Audi</b>	All Except Super 90 & 100 Series	14mm -1.5	M-515	M-525
<b>BMW</b>	All up to 1980 1981 & Later	22mm -1.5 14mm -1.5	M-519 M-515	M-525 M-525
<b>Buick</b>	1959-Present: Except 2.5L 4.3L 4.9L 2.8L 2.5L 4.3L 4.9L Eng. & 87'-Present 2.8L	1/2" - 20 UNF 12mm -1.75	M-501 M-513	M-525 M-525
<b>Cadillac</b>	1966-Present: Except V8 250 (4.1L) V8 250 (4.1L) Engines	1/2" - 20 UNF 12mm -1.75	M-501 M-513	M-525 M-525
<b>Chevrolet</b>	1928-Present: Except Eng. Listed Below 1985 - Present Nova 1976-1982 Luv 1.5L, 1.8L, 1.9L, 2.2L Diesel & Sprint Eng Chevy 350, 5.7L/ 8 cyl. After 1994 Chevy Pickup 6.5L/6.2L Diesel 1996-Present 2.5L, 4.3L, 4.9L & 1987-Present 2.8L Eng	1/2" - 20 UNF 12mm -1.25 20mm -1.5 14mm -1.5 12mm -1.75 12mm -1.75 12mm -1.75	M-501 M-511 M-518 M-515 M-513 M-513 M-513	M-525 M-525 M-525 M-525 M-525 M-525 M-525
<b>Chrysler</b>	1962-Present: Except 2.6L & 3.0L 2.6L & 3.0L Engines from 1982 1/2 on	1/2" - 20 UNF 14mm -1.5	M-501 M-515	M-525 M-525
<b>Dodge</b>	1962-Pres: Except 1.7L 2.6L 3.0L & Mitsubishi 2.6L up to 1982 and all Mitsubishi up to 1982 5.9L Cummins Diesel 5.2L 1.7L, 3.0L, 1982-Pres 2.6L & Mitsubishi 1982-	1/2" - 20 UNF 18mm -1.5 22mm -1.5 1/2" - 20 UNF 14mm -1.5	M-501 M-517 M-519 M-501 M-515	M-525 M-525 M-525 M-525 M-525
<b>Ford</b>	1957-Present, all Except Eng. Listed Below 4Cyl. 2.8L 2.9L 3.0L 3.3L 3.8L 4.0L 7.5L (460) 1994 7.3L Diesel w/ Int'l Engine F150 F250 1995-Present Powerstroke Superduty 10cyl. 6.8L	1/2" - 20 UNF 14mm -1.5 14mm -1.25 14mm -1.5 14mm -1.25 14mm -1.5	M-501 M-515 M-514 M-515 M-514 M-515	M-525 M-525 M-525 M-525 M-525 M-525
<b>GMC</b>	1939-Pres: Except 1.9L, 2.2L, 2.5L Engines 1.9L and 2.2L Engines 2.5L, 4.3L & 1987-Pres 2.8L Engines	1/2" - 20 UNF 14mm -1.5 12mm -1.75	M-501 M-515 M-513	M-525 M-525 M-525
<b>Honda</b>	All up to 1983 1984-Present, ALL	20mm -1.5 14mm -1.5	M-518 M-515	M-525 M-525



## Quick Changer Engine Oil Drain System For Cars & Light Trucks

Engine	Model	Size	Part	Hose
<b>Hyundai</b>	All	14mm -1.5	M-515	M-525
<b>Infiniti</b>	All	12mm -1.25	M-511	M-525
<b>Isuzu</b>	2 X 4 Pup Engines All Others	20mm -1.5 14mm -1.5	M-518 M-515	M-525 M-525
<b>Jeep</b>	1974-Present	1/2" - 20 UNF	M-501	M-525
<b>Lincoln</b>	1959-Present: Except 2.4L 3.8L (232) Engines 3.8L (232) Engines	1/2" - 20 UNF 14mm -1.5	M-501 M-515	M-525 M-525
<b>Mazda</b>	All	14mm -1.5	M-515	M-525
<b>Mercedes</b>	All Models up to 1981 All Models from 1982-1985 1986-Present 190's, 300D's, 300E's 1986-Present V8 Engines	26mm -1.5 12mm -1.5 14mm -1.5 26mm -1.5	M-522 M-512 M-515 M-522	M-526 M-525 M-525 M-526
<b>Mitsubishi</b>	All	14mm -1.5	M-515	M-525
<b>Nissan</b>	1983-Present Sentra & Pulsar, 1984 200SX all 300ZX & 84'-Pres. 4x4 pickups,85'-Pres.Maxima 1986-Present Stanza Wagon 505 Gas Turbo	12mm -1.25 12mm -1.25 12mm -1.25 20mm -1.5	M-511 M-511 M-511 M-518	M-525 M-525 M-525 M-525
<b>Porsche</b>	911 (All) 926 (up to 81") 930 (up to 77") 928 (82' and on) 930 (78' and on) 944 (All) 924 (All) All 912E, 914	22mm -1.5 20mm -1.5 26mm -1.5 12mm -1.5	M-519 M-518 M-522 M-512	M-525 M-525 M-526 M-525
<b>Renault</b>	All	16mm -1.5	M-516	M-525
<b>Saab</b>	All	14mm -1.5	M-515	M-525
<b>Subaru</b>	All	20mm -1.5	M-518	M-525
<b>Suzuki</b>	All	14mm -1.5	M-515	M-525
<b>Toyota</b>	85'-Pres Tercel,celica,MR2, gas Corolla,gas Pup 1986-Present Van, 1988-Present Camry All Others Except Land Cruise	12mm -1.25 12mm -1.25 18mm -1.5	M-511 M-512 M-517	M-525 M-525 M-525
<b>Volkswagon</b>	All Water Cooled Engines	14mm -1.5	M-515	M-525
<b>Volvo</b>	All 4 cyl. engines. Other Engines up to 1975 All V6 Engines (1976-1982) 1983-Pres V6 Engines.Turbo Diesel Engines	3/4" - 16 UNF 16mm -1.5 18mm -1.5	M-502 M-516 M-517	M-525 M-525 M-525



## Bio-Friendly Cleaners and Degreasers



### LIGHTNING STRIP

Qual #: 51005  
Very aggressive stripper.  
5 Gal Pail  
Available in 55 Gal  
Drums and 275 Gal Totes



### DIAMOND22

Qual #: 52005  
Thermoplastic metal  
interlock floor polish.  
5 Gal Pail  
Available in 55 Gal  
Drums and 275 Gal Totes



### DIAMOND25

Qual #: 55005  
Thermoplastic metal  
interlock floor polish.  
5 Gal Pail  
Available in 55 Gal  
Drums and 275 Gal Totes



### IMAGE

Qual #: 42001  
Deep clean concrete  
surfaces like nothing else!  
2x1 Gal



### STRIP EASE

Qual #: 42002  
Non-Rinse solution enhances  
Boost stripping performance,  
leaving floors ready for finish  
in One Pass!  
2x1 Gal  
Available in 55 Gal Drums



### MIGHTY SCRUB

Qual #: 42003  
Deep clean resilient  
flooring & enhance  
Boost Performance!  
2x1 Gal



### NEUTRAL PLUS

Qual #: 42004  
Add shine & deep clean  
resilient flooring in one  
step while enhancing  
Boost performance!  
2x1 Gal



### OXY GREEN

Qual #: 18512  
All Purpose DFE Peroxide  
Cleaner Concentrate  
4x1 Gal



### 40:1 GLASS CLEANER

Qual #: 654  
Concentrate  
2x1 Gal



### B.B.C

Qual #: BBC  
Heavy Duty Baseboard  
Cleaner  
12/18 oz Aerosol Cans



### OVEN & GRILL CLEANER

Qual #: 23006  
Low Odor Cleaner  
6x1 Qt



### MICROBEST FLOOR WASH

Qual #: 10001  
Two Part Microbial  
Cleaner, Portion  
Control Concentrate,  
120 packets



Qual #: 30002  
One Part Microbial  
Cleaner Concentrat  
1x2 Gal cs





# QUALITY INDUSTRIES INC.

THERE IS NO SUBSTITUTE FOR **QUALITY**

*Quality Industres, Inc. 1595 Ocean Ave. Unit B1, Bohemia, NY 11741*  
*Tel: 631-981-3354 Fax: 631-981-3664 [info@quality-industriesinc.com](mailto:info@quality-industriesinc.com)*